

Glow worm

Installation & Servicing Instructions

To be left with the user

Energysaver

80P

G.C. 41 319 85

HIGH EFFICIENCY BOILER

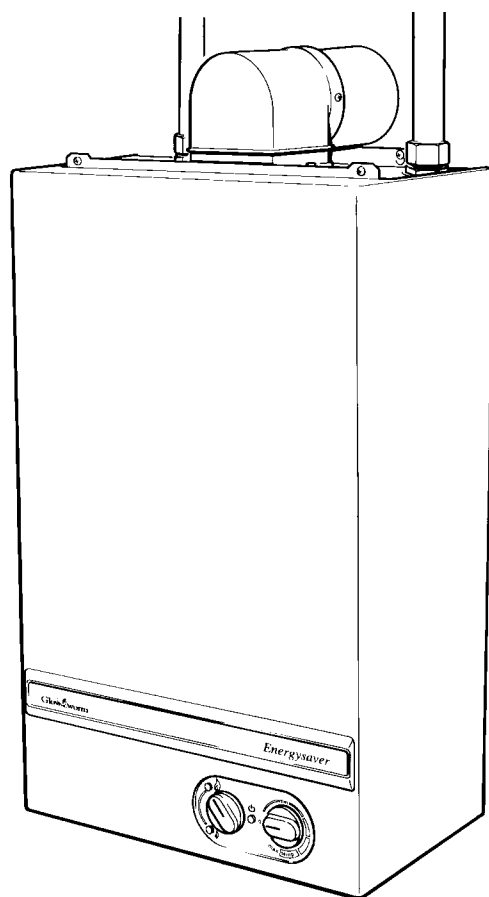

CE

This is a Cat I_{3P} appliance



PAS010

Reference in these instructions to British Standards and Statutory Regulations/Requirements apply only to the United Kingdom. For Ireland the rules in force must be used.

4040 S

HEATCALL Customer Services:
Tel: (01773) 828100
One Contact Local Service Fax: (01773) 828070

Hepworth Heating Ltd.,
Nottingham Road, Belper, Derbyshire. DE56 1JT
General/Sales enquiries :
Tel: (01773) 824141 Fax: (01773) 820569

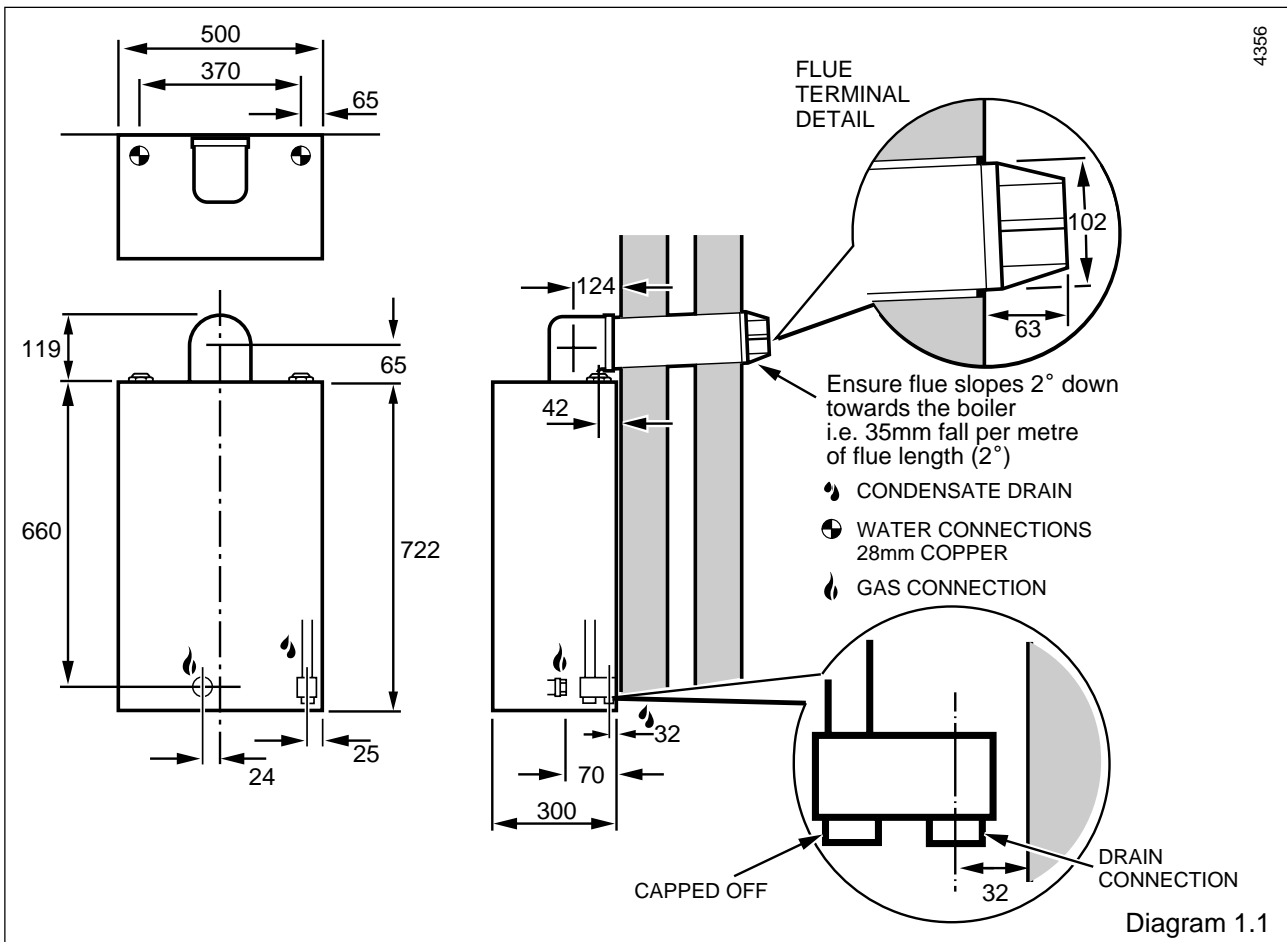

The instructions consist of two parts, Installation and Servicing Instructions and Instructions for Use, which includes the Guarantee Registration Card. The instructions are an integral part of the appliance and must, to comply with the current issue of the Gas Safety (Installations and Use) Regulations, be handed to the user on completion of the installation.

Important Notice

This boiler is for use on liquid petroleum gas Propane LPG (G31) and cannot be used on any other gas.

The boiler is delivered in one pack.

Wherever possible, all materials and components to be used shall comply with the requirements of applicable British Standards.

Where no British Standard exists, materials and equipment should be fit for their purpose and of suitable quality and workmanship.

This boiler must have fully pumped circuits, but is suitable for use with open vented or sealed water systems.

This boiler is not suitable for outdoor locations.

This boiler must not be fitted in a basement or cellar.

1.1 Sheet Metal Parts

WARNING. When installing or servicing the boiler care should be taken when handling sheet metal parts to avoid any possibility of personal injury.

1.2 Statutory Requirements

The installation of the boiler **MUST** be carried out by a competent person in accordance with the relevant requirements of the current issue of:

The manufacturer's instructions supplied.

The Gas Safety (Installation and Use) Regulations, The Building Regulations, The Building Standards (Scotland) Regulations (applicable in Scotland), The Building Regulations (Northern Ireland), local Water Company Bylaws, The Health and Safety at Work Act, Control of Substances Hazardous to Health, The Electricity at Work Regulations and any applicable local regulations.

Detailed recommendations are contained in the current issue of the following British Standards and Codes of Practice, BS4814, BS5440 Part 1 and 2, BS5449, BS5546, BS6700, BS6798, BS5482 Part 1, BS7074 Part 1 and 2, BS7478, BS7593, BS7671.

LP Gas Association Code of Practice 22, 24 Part 1 and CP 25.

We also suggest that you have to hand a copy of the British Gas publication, "Guidance Notes for the Installation of Domestic Condensing Boilers".

Manufacturer's notes must not be taken as overriding statutory obligations.

DATA TABLE 1.

DATA TABLE 1.	
MODEL	80P
TOTAL WEIGHT	51.0 kg (112.5 lb)
LIFT WEIGHT	35.5kg (78.5 lb)
WATER CONTENT	2.0 Litre (0.44 gall)
GAS CONNECTION	Rc 1/2 in.
WATER CONNECTION	28mm copper, flow at right, return at left
ELECTRICITY SUPPLY	240V ~ 50HZ, fused 3A.

TABLE 2. Energysaver 80P

RANGE RATING	LOW	MIN	MID	MAX
NOMINAL HEAT INPUT (GROSS) <i>kW</i> <i>Btu/h</i>	15.0 51,100	20.0 68,200	23.3 79,500	26.6 90,900
NOMINAL HEAT OUTPUT <i>kW</i> <i>Btu/h</i>	13.2 45,000	17.6 60,000	20.5 70,000	23.4 80,000
NOMINAL HEAT OUTPUT CONDENSING <i>kW</i> <i>Btu/h</i>	14.0 47,500	18.6 63,400	21.7 74,000	24.8 84,500
BURNER SETTING (HOT) PRESSURE <i>mbar</i> <i>in.w.g</i>	9.6 3.8	16.3 6.5	22.2 8.9	29.0 11.6
APPROX GAS RATE <i>m³h</i> <i>ft³h</i>	0.56 19.9	0.75 26.5	0.88 30.9	1.0 35.4
BURNER INJECTOR MARKING: 80P				

BSI Certification

The boiler is certificated to the current issue of P.A.S. 010 for performance and safety.

It is important that no alteration is made to the boiler, without permission, in writing, from Hepworth Heating Ltd.

Any alteration that is not approved by Hepworth Heating Ltd., could invalidate the warranty and could also infringe the current issue of the Statutory Requirements.

CE Mark

The boiler meets requirements of Statutory Instrument “The Boiler (Efficiency) Regulations 1993 No. 3083” and is deemed to meet the requirements of Directive 92/42/EEC on the efficiency requirements for new hot water boilers fired with liquid or gaseous fuels.-

Type test for purpose of Regulation 5 certified by: Notified Body 0086.

Product/production certified by: Notified Body 0086.

The CE Mark on this appliance shows compliance with:-

1. Directive 90/396/EEC on the approximation of the Laws of the Member States relating to appliances burning gaseous fuels.
2. Directive 94/42/EEC on efficiency requirements for new hot water boilers fired with liquid or gaseous fuel is also complied with.
3. Directive 73/23//EEC on the harmonization of the Laws of the Member States relating to electrical equipment designed for use within certain voltage limits.
4. Directive 89/336/EEC on the approximation of the Laws of the Member States relating to electromagnetic compatibility.

1.3 Range Rating

The boiler is range rated and is factory preset to maximum, but may be adjusted to suit individual system requirements, refer to Table 2.

1.4 General Data

The data label is positioned on the inner case, visible when the outer case is removed.

All dimensions on diagrams are given in millimetres (except as noted).

1.5 Gas Supply

The gas installation must be in accordance with the current issue of BS5482 Part 1. On completion, test the gas installation for soundness using the pressure drop method and purge in accordance with the above standard.

1.6 Propane LPG - Storage

Propane LPG cylinders are under pressure and should never be stored or used indoors residentially.

They should only be kept out of doors.

Under no circumstances must LPG cylinders be fitted or stored in basement areas. The gas supply should be from standard containers, the regulators of which should be fitted in accordance with the manufacturer’s instructions.

The supply must be capable of providing the required gas rate with due regard to other appliances using the same supply.

1.7 Electrical Supply

WARNING. This boiler must be earthed.

All system components shall be of the approved type and be wired and connected in accordance with the requirements of the current issue of BS7671 and any applicable local regulations.

Connection of the boiler and system controls to the mains supply must be through a common isolator and must be fused 3A maximum. This method of connection should be, by a double pole isolating switch, which has a minimum contact separation of 3mm on both poles. This should be readily accessible and preferably adjacent to the appliance. It should supply the appliance only and be easily identifiable as so doing.

Alternatively, an unswitched shuttered socket outlet and 3A fused 3 pin plug both to the current issue of BS1363 may be used, provided that they are not used in a room containing a bath or shower.

Wiring to the boiler must be PVC insulated type to the current issue of BS6500 Table 16.

1.8 Condensate

The boiler condensate should, if possible, be discharged into the household internal draining system, that is, sink or washing machine drain. If this is not practicable, discharge can be external, into the household drainage system or a purpose designed soak away

The boiler is fitted with a safety device to prevent the boiler from working if the condensate pipe gets blocked by either ice or debris. It is, therefore, recommended that any external condensate drain pipe is insulated to prevent freezing up. Alternately, a larger diameter pipe can be used and insulated. The condensate drain pipe should be checked during any servicing and any debris found removed..

Refer to the British Gas publication "Guidance Note for the Installation of Domestic Condensing Boilers" for further information.

NOTE: The boiler has 28mm connections.

2.1 Draining Tap

The boiler is provided with a draining point at the lower left hand side of the burner manifold, to be used for draining the boiler, see diagram 2.1.

A draining tap must be provided at the lowest points of the system which will allow the entire system and hot water cylinder to be drained.

Draining taps shall be to the current issue of BS2879.

2.2 Safety Valve

A safety valve need not be fitted to an open vented system.

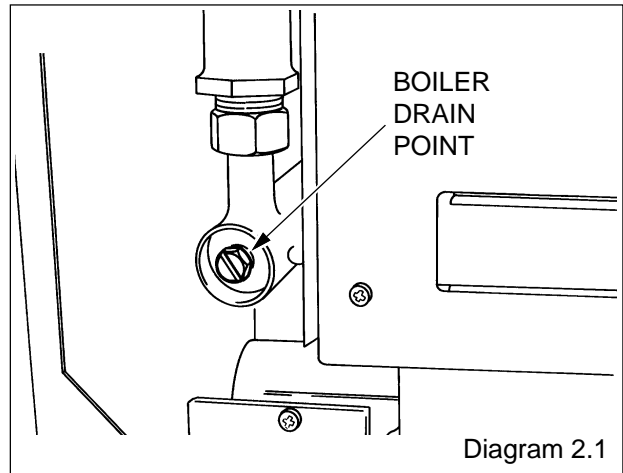

2.3 Pump

The pump should be fitted in the flow pipe from the boiler and have isolating valves each side, integral if possible.

A variable duty pump should be set to give a temperature difference of 11°C (20°F) between the flow and return, with the thermostat set at “MAX”, which is about 82°C (180°F), to give a design flow rate as shown in Table 3.

See chart for pressure drop of the boiler, diagram 2.2.

The use of microbore systems is not recommended.

2.4 Bypass

A BYPASS MUST BE FITTED, see diagram 2.3 for a suitable position.

The flow rate through the boiler must not be allowed to fall below that given in Table 3.

Where the water system can allow the boiler and pump to operate on bypass only, the bypass must be placed at least 1.5m away from the boiler.

2.5 Inhibitor

Attention is drawn to the current issue of BS5449 and BS7593 on the use of inhibitors in central heating systems.

If an inhibitor is to be used, contact an inhibitor manufacturer for their recommendations as to the best product to use.

Note: This boiler has a totally copper water system and does not require a special inhibitor normally associated with other types of high efficiency (“condensing”) boilers.

If an existing system is to be reused take special care to drain the entire system, including the radiators, then thoroughly cleaning out before fitting the boiler whether or not adding an inhibitor.

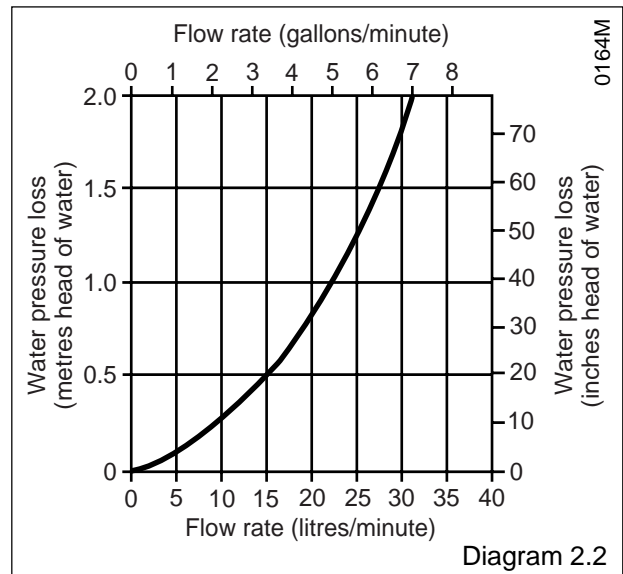

TABLE 3

	Design Flow Rate	Minimum Flow Rate
<i>Energysaver 80P</i>	30.5L/min	23L/min

2.6 Open (Vented) Water System

The boiler must be supplied from an unrestricted water supply taken from a feed and expansion cistern situated at a maximum height of 27metres (90ft) above the boiler.

Maximum water pressure 3 Bar.

The cold feed must be 15mm minimum size.

The vent must rise continuously and be unrestricted.

It is important that the relative positions of the pump, cold feed and open vent are as shown in diagram 2.3.

2.7 Domestic Hot Water Cylinder

The domestic hot water cylinder must be of the double feed fully indirect type. Not the single feed self priming type.

2.8 Domestic Hot Water System - Unvented

Where a storage system will not have a vent to atmosphere the installation must comply with the Building Regulations and local Water Company bylaws, see also the current issue of BS5546 and BS6700.

If fitting to an existing system the local authority should be informed.

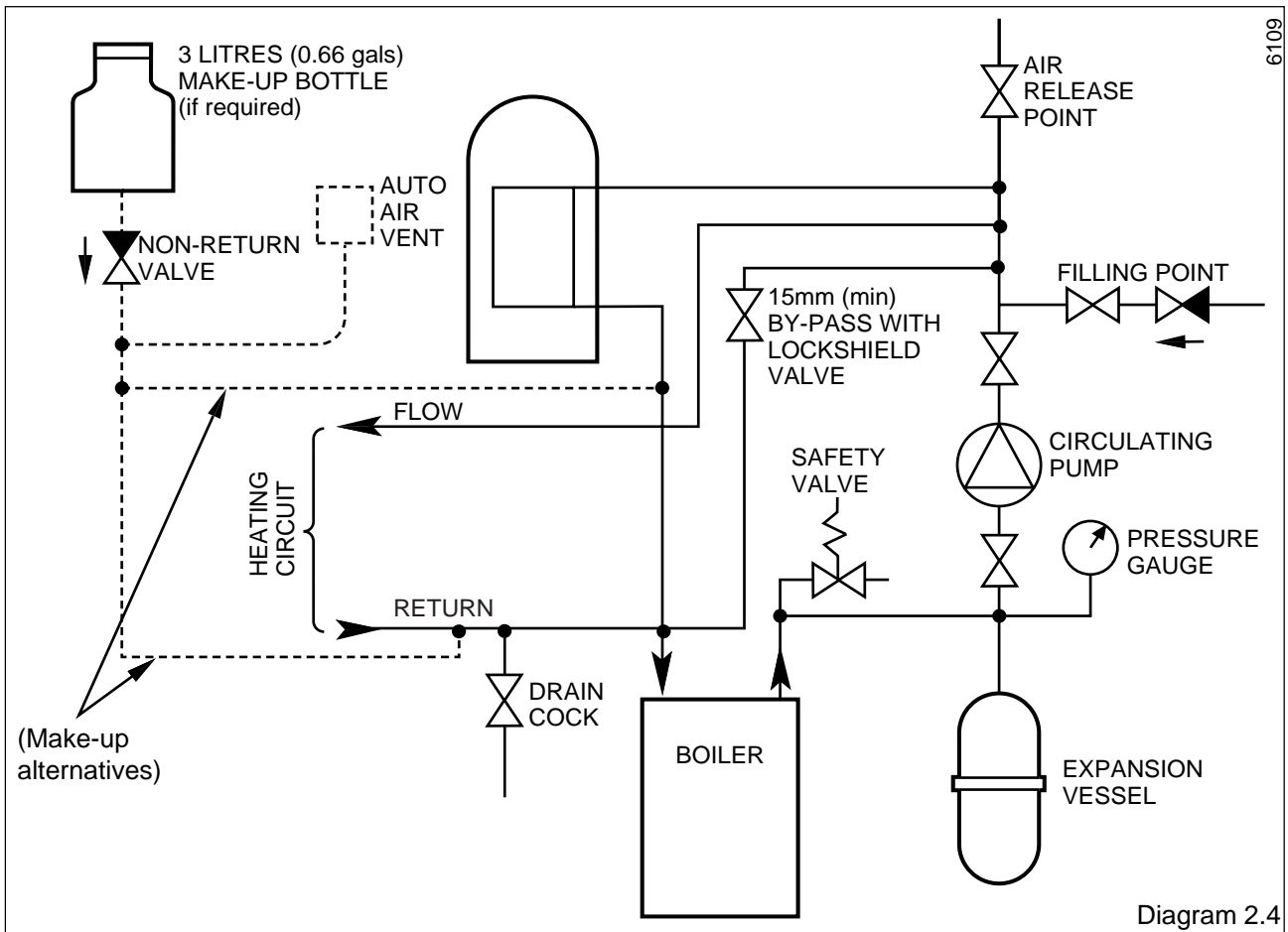
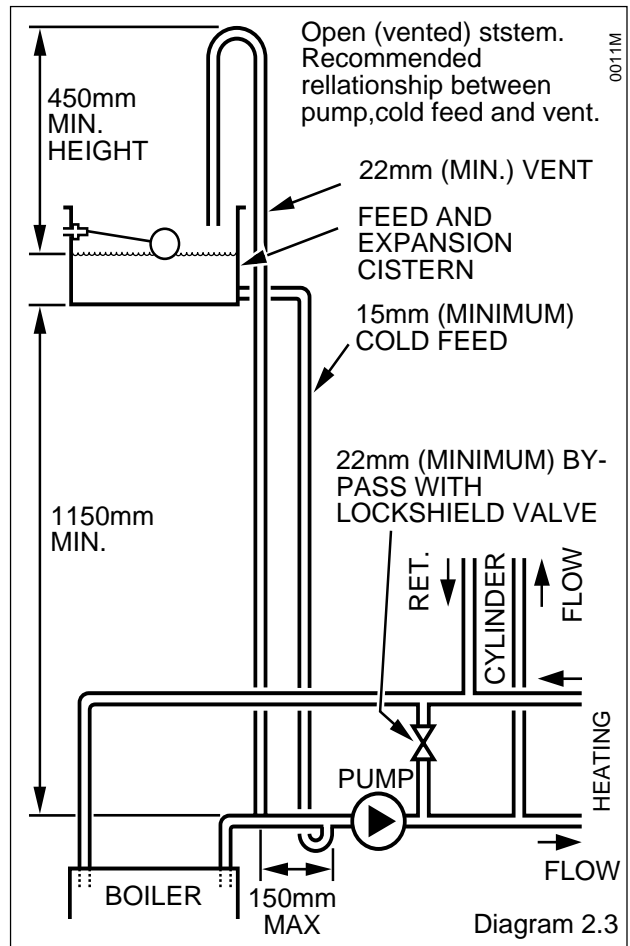

2.9 Sealed Water Systems

The installation must comply with the appropriate requirements of the current issue of BS4814, BS5449, BS6759, BS6798 and BS7074 Part 1 and 2.

See diagram 2.4 for a suggested layout.

2.10 Safety Valve

A safety valve must be fitted to a sealed system.

It shall be preset, nonadjustable with a lift pressure of 3bar, incorporating seating of a resilient material, a test device and a connection for drain.

The drain from the safety valve must be routed clear of any electrical fittings and positioned so that any discharge can be seen.

2.11 Expansion Vessel

A diaphragm type expansion vessel, conforming to the current issue of BS4814 (see also BS7074 Part 1 and 2) must be connected at a point close to the inlet side of the circulating pump, see the diagrammatic layout, diagram 2.4 unless laid down differently by the manufacturer.

The expansion vessel volume depends on the total water system volume and the initial system design pressure. For any system an accurate calculation of vessel size is given in the current issue of BS7074 Part 1.

Example: For an initial system design pressure of 0.7bar, the minimum total vessel volume required is $0.063 \times \text{Total System volume}$.

Note: A higher initial design pressure requires a larger volume expansion vessel.

Guidance on vessel sizing is also given in the current issue of BS5449 and BS7074 Part 1.

The charge pressure must not be less than the static head of the system, that is, the height of the highest point of the system above the expansion vessel.

The water content of the boiler is given in the Data Table 1.

2.12 Pressure Gauge

A pressure gauge with a set pointer and covering at least 0 to 4bar (0 to 60lb/in²) shall be fitted permanently to the system in a position where it can be seen when filling the system.

2.13 Domestic Hot Water Cylinder

SINGLE FEED INDIRECT CYLINDERS ARE NOT SUITABLE.

The hot water cylinder must be of the indirect coil type. It must be suitable for working at a gauge pressure of 0.35bar above the safety valve setting.

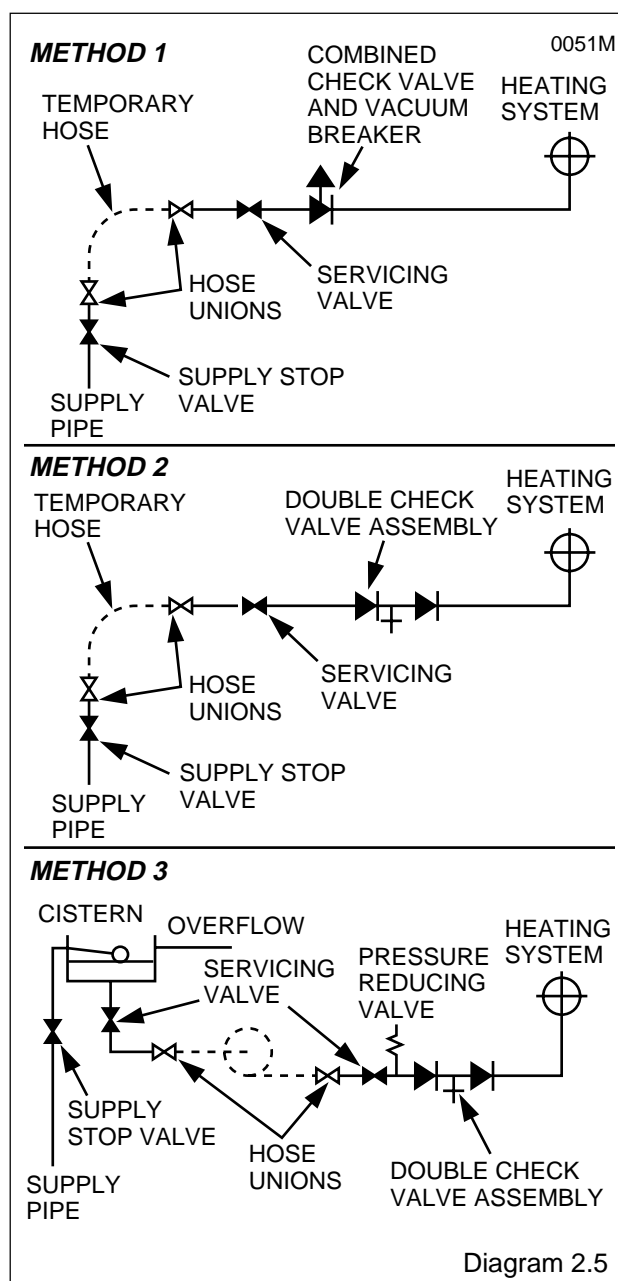

2.14 Water Makeup

Provision should be made for replacing water loss from the system using a make up bottle or filling loop mounted in a position higher than the top point of the system, connected through a non-return valve to the return side of either the heating circuit or the hot water cylinder.

Alternatively, provision for make up can be made using a filling loop.

2.15 Filling a Sealed Water System

Provision for filling the system at low level must be made. Three methods are shown in diagram 2.5. There must be no permanent connection to the mains water supply, even through a non-return valve.

NOTE:

The boiler may be installed in any room, except a basement, although particular attention is drawn to the requirements of the current issue of BS7671 with respect to the installation of a boiler in a room containing a bath or shower.

Any electrical switch or boiler control using mains electricity should be so situated that it cannot be touched by a person using the bath or shower. The electrical provisions of the Building Standards (Scotland) Regulations are applicable to such installations in Scotland.

The boiler must be mounted on a flat wall which is sufficiently robust to take its total weight, see Data Table 1.

3.1 Boiler Clearances

The boiler must be positioned so that at least the minimum operational and servicing clearances are as shown in diagram 3.1.

Additional clearances may be required around the boiler for installation purposes, dependent upon site conditions.

3.2 Timber Frame Buildings

If the boiler is to be installed in a timber frame building, it should be fitted in accordance with the British Gas publication “Guide for Gas Installation in Timber Framed Housing” reference DM2. If in doubt, seek advice from the local gas undertaking or Hepworth Heating Ltd.

3.3 Room Ventilation

The boiler is room sealed, so when installed in a room or space a permanent air vent is not required.

3.4 Cupboard or Compartment Ventilation

Where the boiler is fitted in a cupboard or compartment, permanent high and low level ventilation must be provided. The ventilation areas required are given in Table 4.

Where the installation of the boiler will be in an unusual location, special procedures are necessary, refer to the current issue of BS6798 for guidance.

Make sure that the cupboard or compartment air vents are positioned to be clear of obstructions at all times.

A compartment used to enclose the boiler must be designed and constructed specifically for this purpose.

The doorway opening should be of sufficient size to allow for easy removal of the boiler.

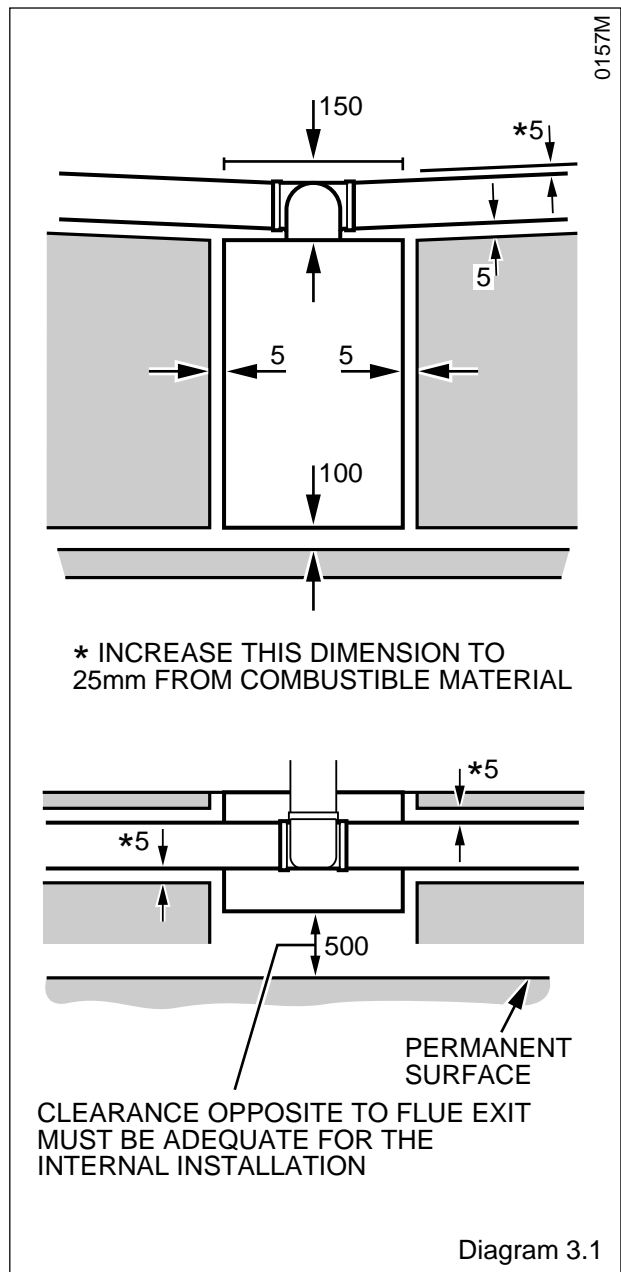

TABLE 4 ENERGYSAVER 80P				
	high level		low level	
	cms	in ²	cms	in ²
Ventilation from room	240	37.2	240	37.2
Ventilation from outside	120	18.6	120	18.6

NOTE.

The flue must be installed in accordance with the current issue of BS5440 Part 1.

Important. The flue must be installed with a fall of: 35mm per metre (2°) TOWARDS the boiler, see diagram 4.1.

It is of no advantage to exceed the angle of 2°, indeed sealing of the fan to the flue elbow may become more difficult as the angle is increased.

The air and flue duct connect to the top of the boiler using an elbow which can be positioned to the side or rear.

The rear and side flue assemblies are designed for internal installation, but if necessary, due to insufficient clearances (boiler/flue terminal location) they can be installed from the outside.

For a wall thickness up to 300mm the flue can be fully installed from the inside.

For a wall thickness over 300mm the external cut hole will need to be made good from the outside.

The standard flue is able to provide the duct lengths as shown in diagram 4.2 for a rear flue and diagram 4.3 for a side flue.

2 and 3metre flue systems with terminals are available, see diagram 4.2 and 4.3.

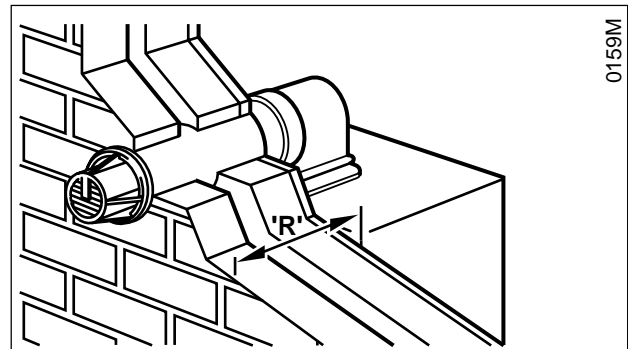

0159M

REAR FLUE LENGTHS	
R = Wall Thickness	
STD Flue pack	75mm to 623mm
2m Flue pack	75mm to 1953mm
3m Flue pack	75mm to 2933mm

Diagram 4.2

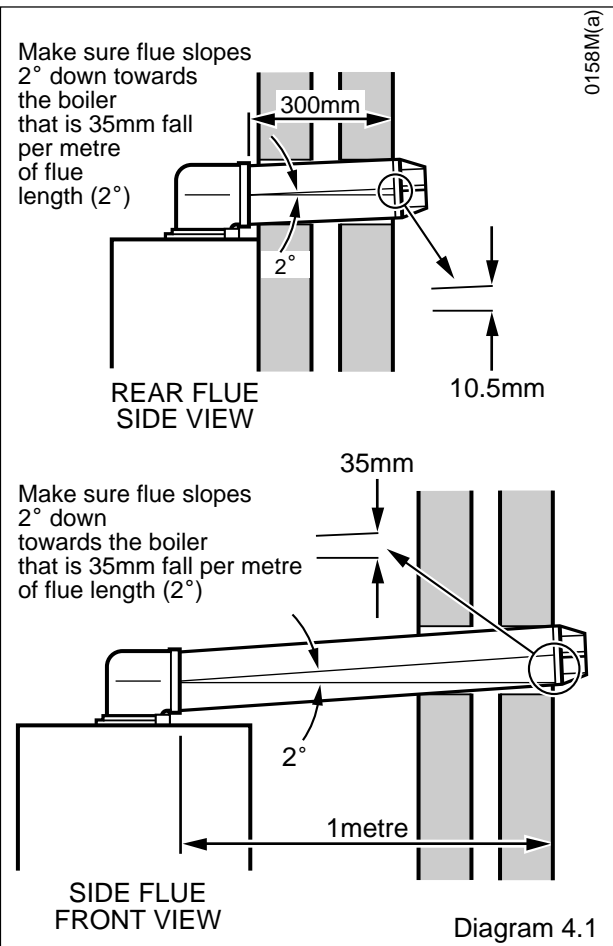

0158M(a)

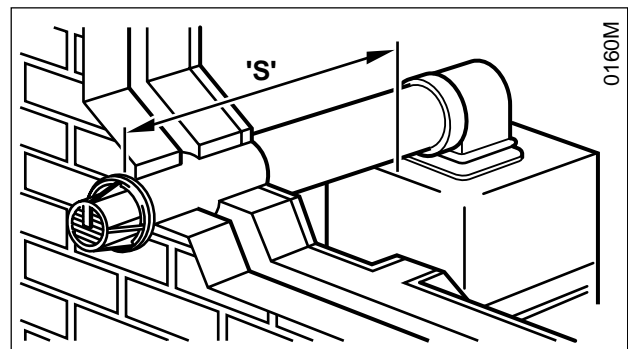

0160M

SIDE FLUE LENGTHS	
S = "External wall face" to "boiler casing"	
STD Flue pack	80mm to 522mm
2m Flue pack	80mm to 1852mm
3m Flue pack	80mm to 2832mm

Diagram 4.3

4.1 Terminal Position

The minimum acceptable spacings from the terminal to obstructions and ventilation openings are as shown in diagram 4.4.

The boiler must be installed so that the terminal is exposed to the external air.

It is important that the position of the terminal allows the free passage of air across it at all times.

Note: The flue will produce a plume of condensation in cold weather, so special care must be taken in the siting of the flue terminal so as not to cause a nuisance to adjacent property.

Where the terminal is fitted within 600mm (24in) below plastic guttering an aluminium shield 1500mm (5ft) long should be fitted to the underside and immediately beneath the guttering or eaves.

Where the terminal is fitted within 450mm (18in) below eaves or painted guttering an aluminium shield 750mm (2ft6in) long should be fitted to the underside and immediately beneath the guttering or eaves.

4.2 Terminal Guard

A terminal guard is required if persons could come into contact with the terminal or the terminal could be subject to damage.

If a terminal guard is required, it must be positioned to provide a minimum of 50mm clearance from any part of the terminal and be central over the terminal, see diagram 4.4.

A suitable terminal guard can be obtained from:

Tower Flue Components Ltd.,
Morley Road,
Tonbridge,
Kent.
TN9 1RA

their reference CGD K3 BL

4.3 Flue Collar Kit

A flue collar kit, part No.443286 (with instructions) is available.

Please note, the use of this collar will mean that the flue lengths will need to be altered, full instructions are given in the kit.

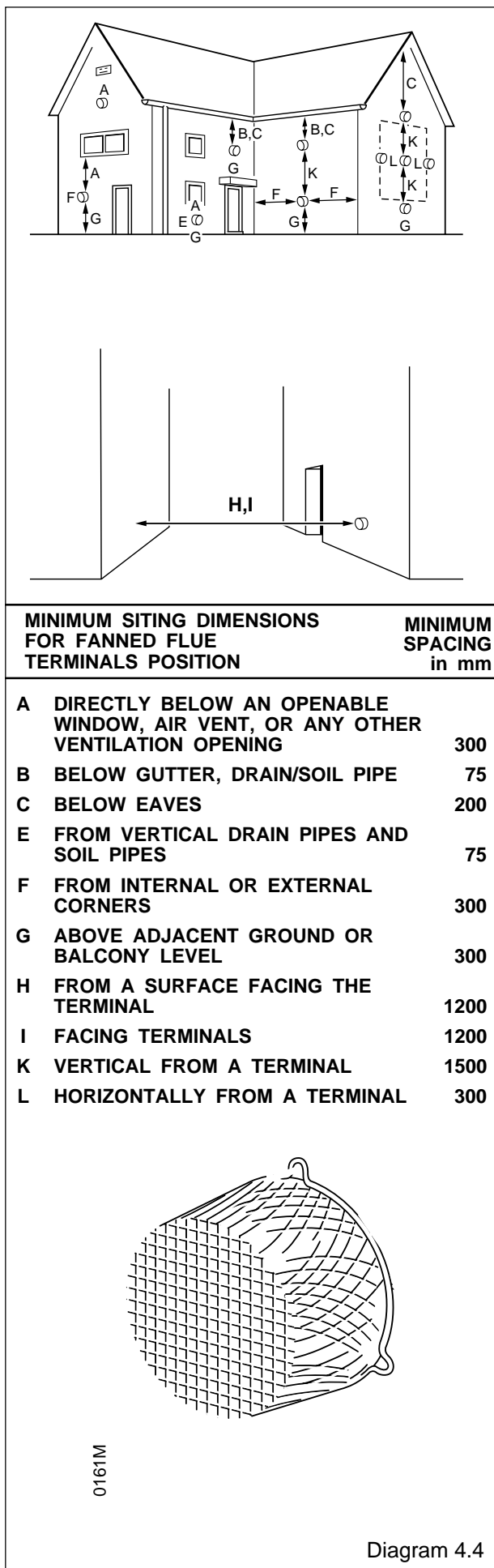

0103 M

0161 M

Diagram 4.4

5.1 Unpacking - refer diagram 5.1

Open carton top, remove top fitting, wall template, loose items pack and boiler mounting bracket. Remove carton wrap and packing pieces.

Lift off white outer case front. Remove protective packing piece.

Remove the cover of the inner case, see diagram 5.3.

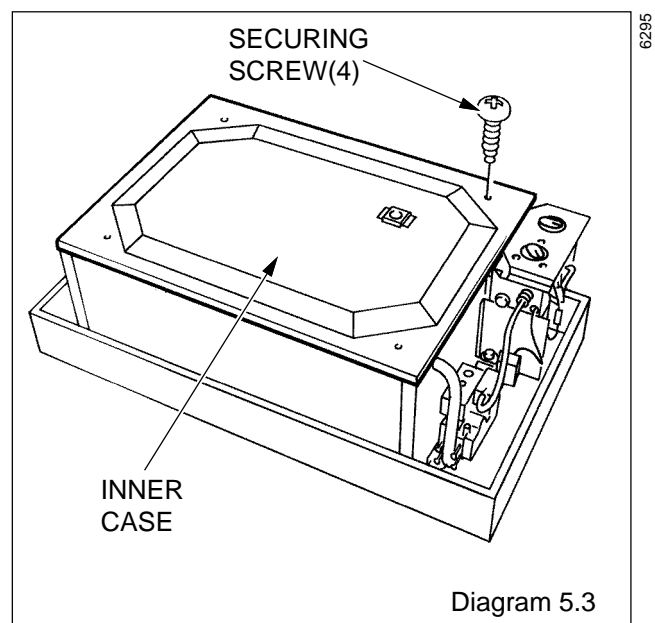
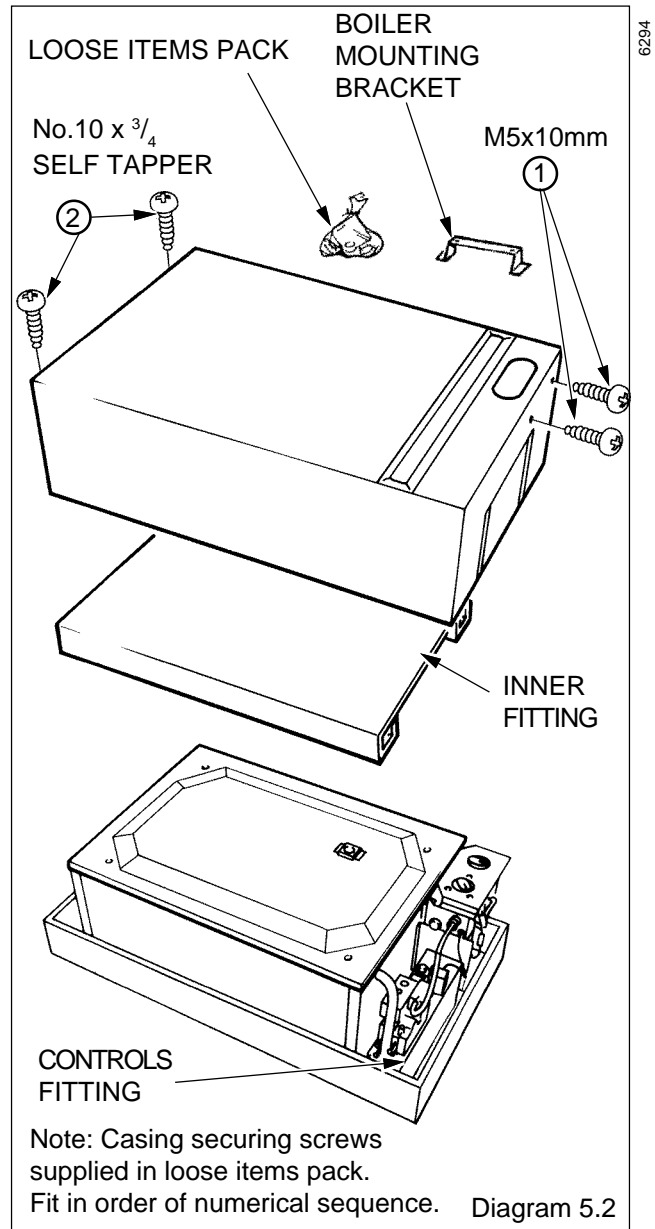
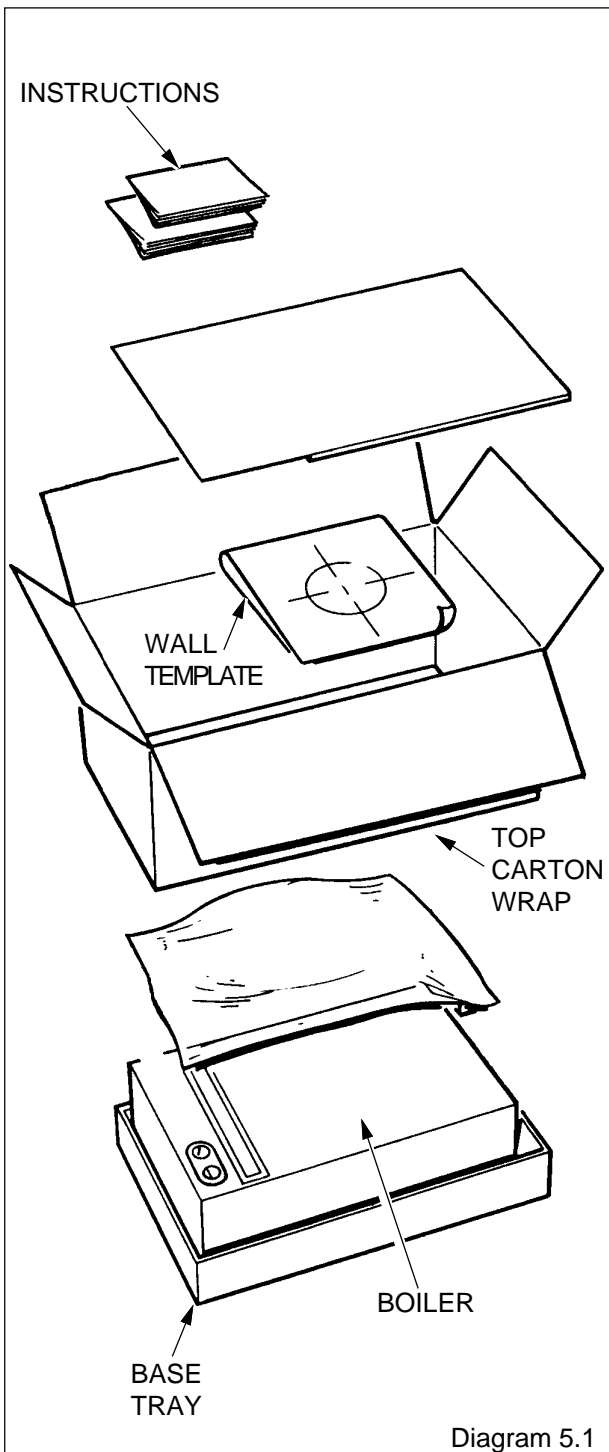

5.2 Rear and Side Flue Application

Having selected the location and flue application, with due regard to the terminal position.

Take the template pack and temporarily position it on the wall, see diagram 5.4, making sure that the minimum clearances are maintained.

For a rear flue, mark the position of the flue as diagram 5.4.

For a side flue, extend the centre line horizontally (taking into account the required fall towards the boiler) left or right to the corner of the adjacent surface where the flue is required to exit to the outside.

Alternatively, the increase in the centre line height over a distance "x" is given by $H=0.035x$. Mark the position of the centre of the flue, as diagram 5.4.

5.3 Flue Hole Cutting

Having marked out the flue centre cut a hole for the flue see diagram 5.4A for minimum core drill size for various wall thicknesses.

This will allow for the 35mm per metre (2°) fall towards the boiler.

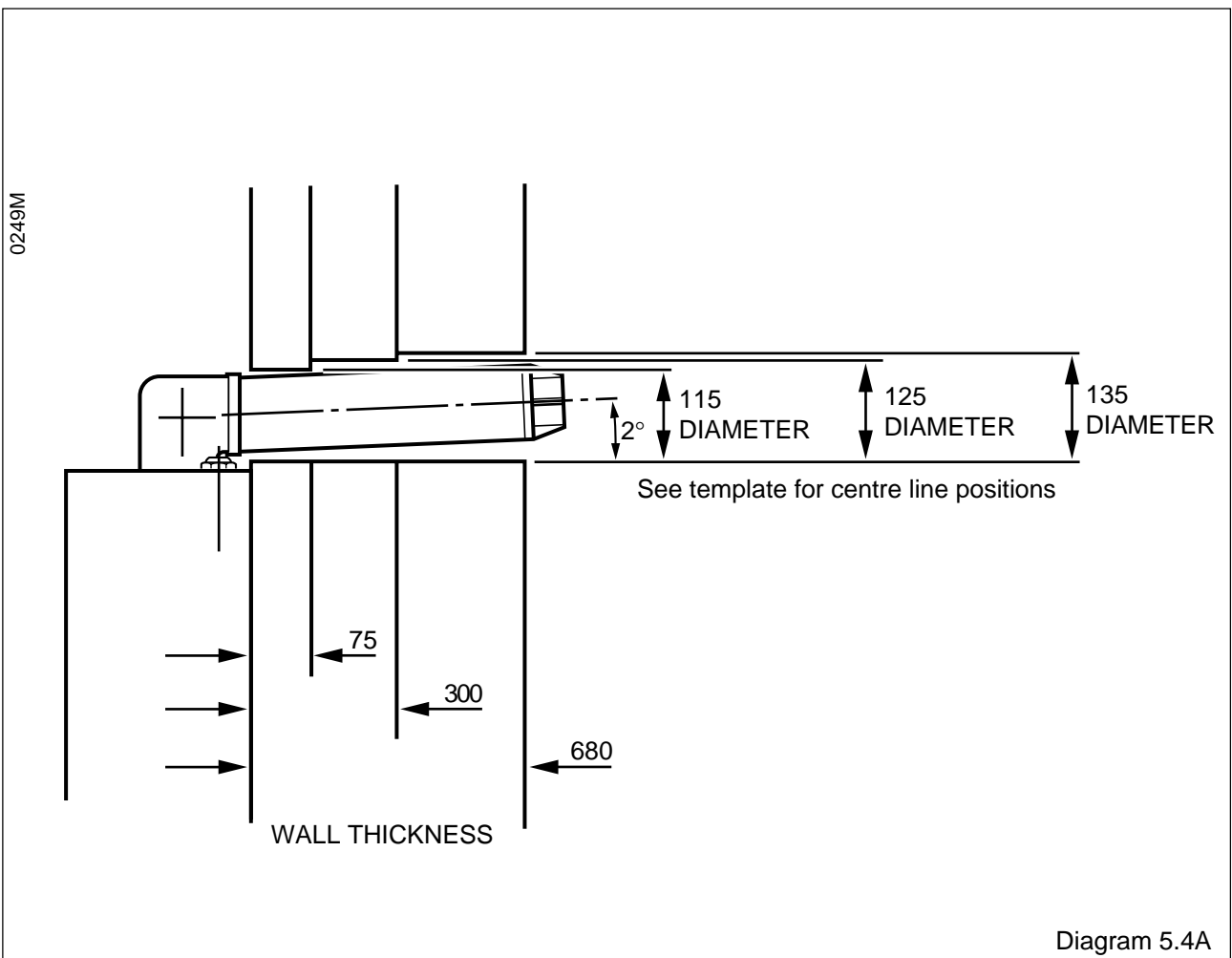
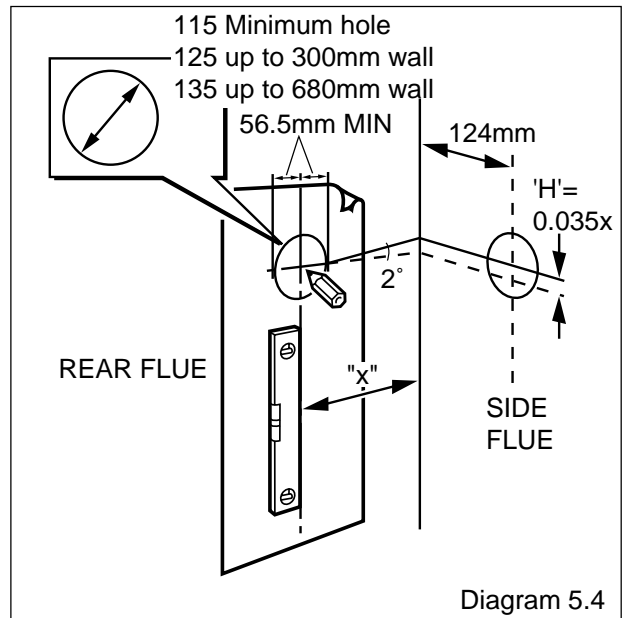

5.4 Wall Sleeve

Take the wall sleeve from the flue pack. If the wall thickness “Q” is less than 300mm cut the wall sleeve to the required length, see diagram 5.5.

Fit the wall sleeve.

Make sure that an angle of 2° is made within the wall, see diagram 5.4B.

Make good around the wall sleeve at both internal and external wall faces, through the wall sleeve if internal access only is available.

If the wall thickness “Q” is greater than 300mm the wall sleeve must be fitted flush with the INSIDE wall face. If the inner end of the liner sticks out into the cavity the wall liner can be trimmed back to the depth of the inner skin of brickwork. Make good at the internal wall face but leave the external wall face until the flue has been installed.

Reposition the template, making sure of dimensional alignment with the flue centre lines.

Mark the boiler securing screws and mounting plate position, see diagram 5.6.

Drill holes and plug, fit the securing screws, allowing sufficient clearance to accept the keyhole fixing brackets and secure the boiler mounting bracket to the wall.

5.5 Boiler Preparation

Lift the boiler into position above the boiler mounting bracket, lowering the boiler into position at the same time locating the key hole slots of the boiler on to the securing screws, when located secure the screws, see diagram 5.6.

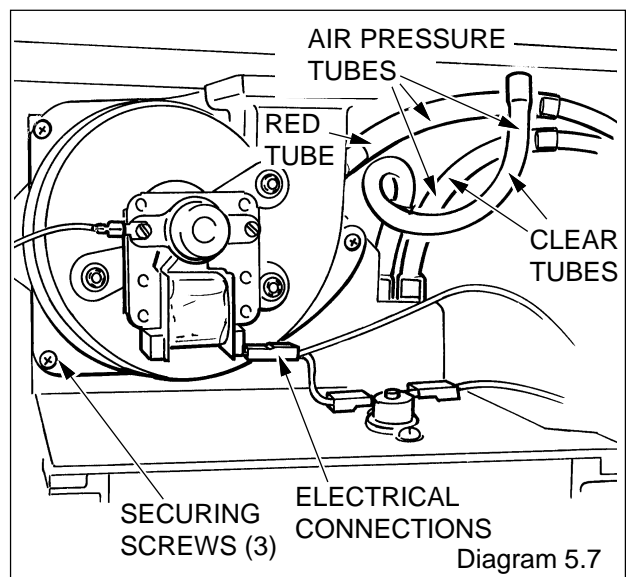
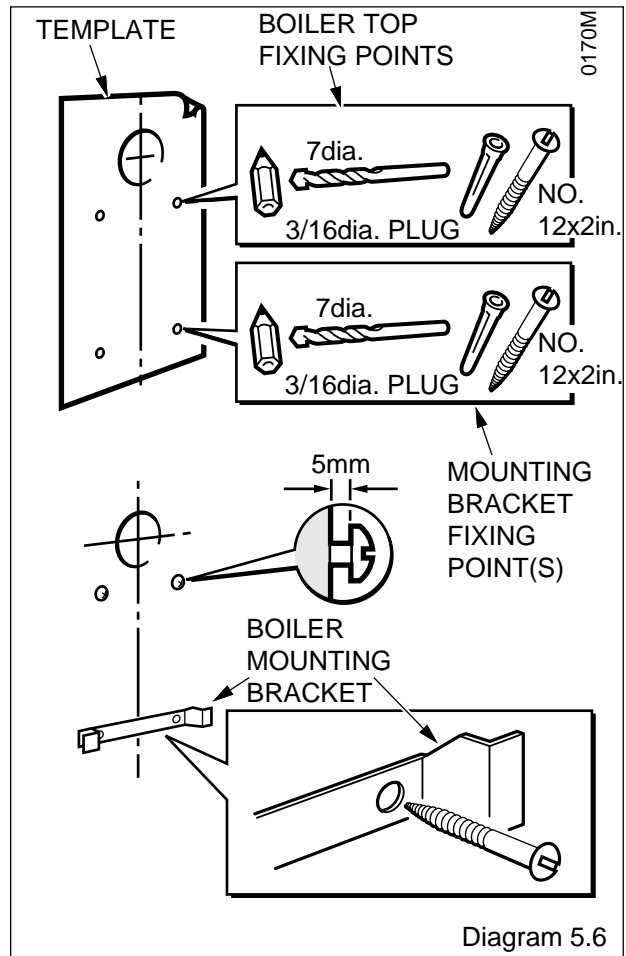
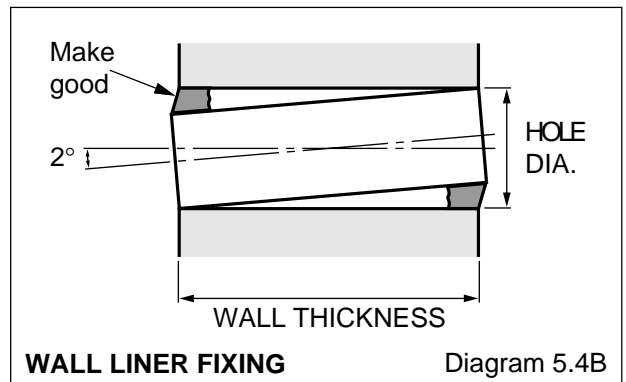
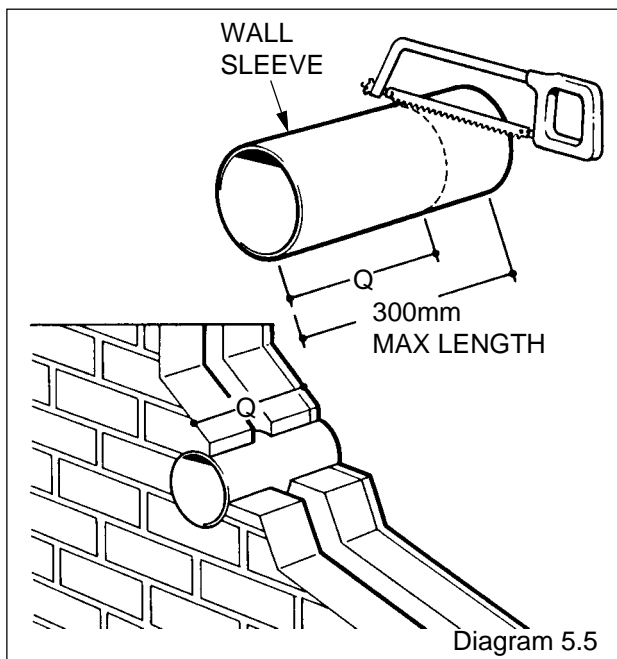

6.1 Water Connections

The water connections to the heating system must be as shown in diagram 6.1.

6.2 Condensate Connection

The condensate drain connection is at the bottom right of the boiler.

The drain ends in a spigot which is suitable for push-fit 22mm(3/4in.) plastic overflow pipe, for example, Hepworth Polypipe, Uponor, Osma, Oracstar. If using Marley, Terrain or Hunter tubing, which is slightly larger, use the silicone sealant provided in the fittings pack to make a leak proof joint to the drain connection on the boiler.

The condensate discharge pipe should have a fall of 2½°.

It is not necessary to provide air breaks, or traps in the discharge pipesince the boiler has an integral 50mm trap and syphon.

The boiler is fitted with a safety device to prevent the boiler from working if the condensate pipe gets blocked by either ice or debris. It is, therefore, recommended that any external condensate drain pipe is insulated to prevent freezing up. Alternatively, a larger diameter pipe can be

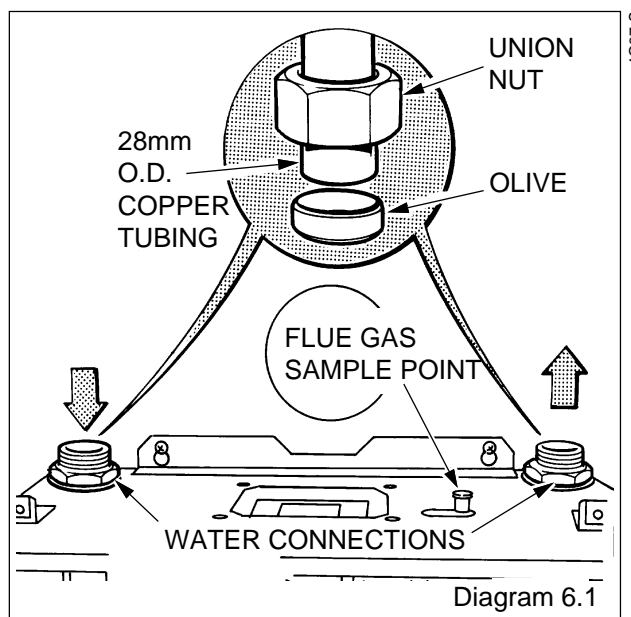

used and insulated. The condensate drain pipe should be checked during any servicing and any debris found removed.

Refer to the British Gas publication “Guidance Notes for the Installation of Domestic Condensing Boilers” for advice on the disposal of the boiler condensate.

7 Flue Installation

7.1 Rear Flue

Mark and cut the air duct terminal assembly, see diagram 7.3 and the flue duct, diagram 7.4 to the lengths required, cutting square and removing any burrs.

Refer to diagram 7.5, mark through the holes in the flue elbow assembly and drill the duct as shown, making sure of the correct alignment of the “Top”.

7.2 Side Flue

Mark and cut the air duct terminal assembly, see diagram 7.6 and flue duct, diagram 7.7 to the lengths required, cutting square and removing any burrs.

Refer to diagram 7.5 mark through the holes in the flue elbow assembly and drill the flue duct as shown, making sure of the correct alignment of the “Top”.

7.3 Internal Flue Assembly

Apply sealant to the flue duct, locate into the air duct terminal, see diagram 7.8.

Apply sealant to the flue elbow spigot and then locate the flue and air duct terminal assembly to the flue elbow as shown in diagram 7.5, making sure of the alignment of the “Top”.

Secure the air duct/terminal assembly to the flue elbow and flue duct assembly with the two self tapping screws supplied in the loose items pack and then seal with the tape provided.

For wall thicknesses up to 300mm fit the self adhesive seal to the air duct, see diagram 7.9., make sure the joint is on top.

For wall thicknesses over 300mm see diagram 7.10.

Place the flue assembly into the flue hole. Make sure that the flue terminal is correctly positioned and projecting the correct distance from the outside wall face, see diagram 7.11.

Note: The foam seal is a tight fit in the wall sleeve, so either the wall sleeve will need to be rigidly fixed, that is, the cement has fully set or it can be held from the other side whilst inserting the flue assembly.

7.4 External Flue Installation

Locate the air duct/terminal assembly into the flue elbow assembly as shown in diagram 7.5, making sure of correct terminal alignment of the “TOP”.

Mark the position of the air duct terminal assembly securing holes and drill two 2.8mm diameter holes through the air duct/terminal assembly.

For wall thicknesses up to 300mm fit the self adhesive seal to the air duct, see diagram 7.9.

For wall thicknesses over 300mm see diagram 7.10.

Apply sealant to the flue duct and locate into air duct terminal, see diagram 7.8.

7 Flue Installation

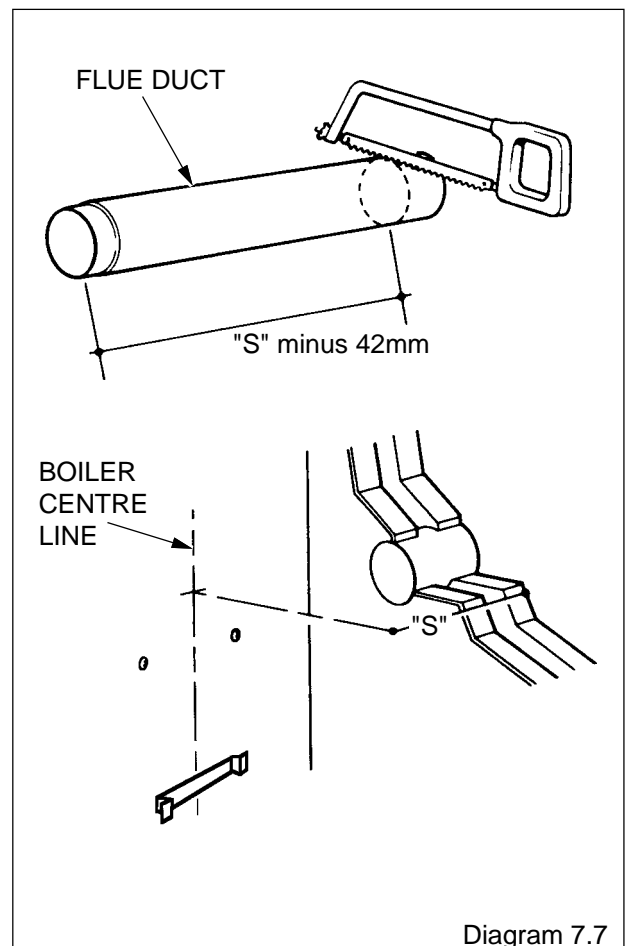
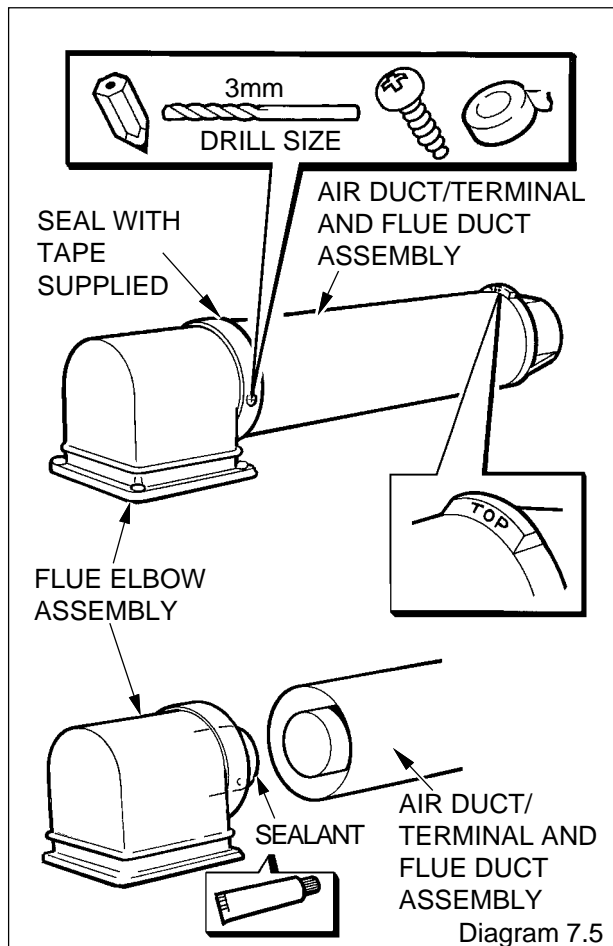
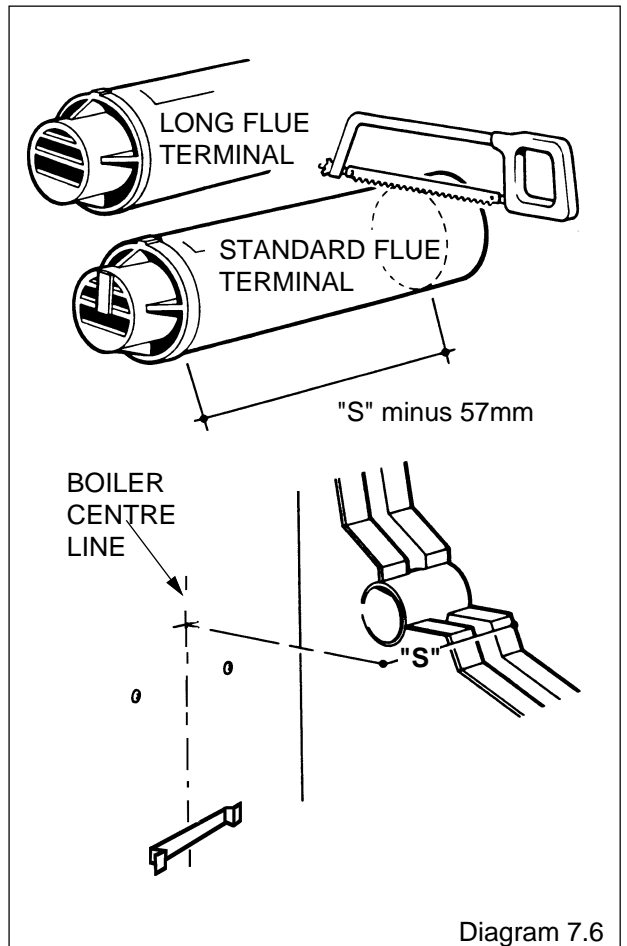
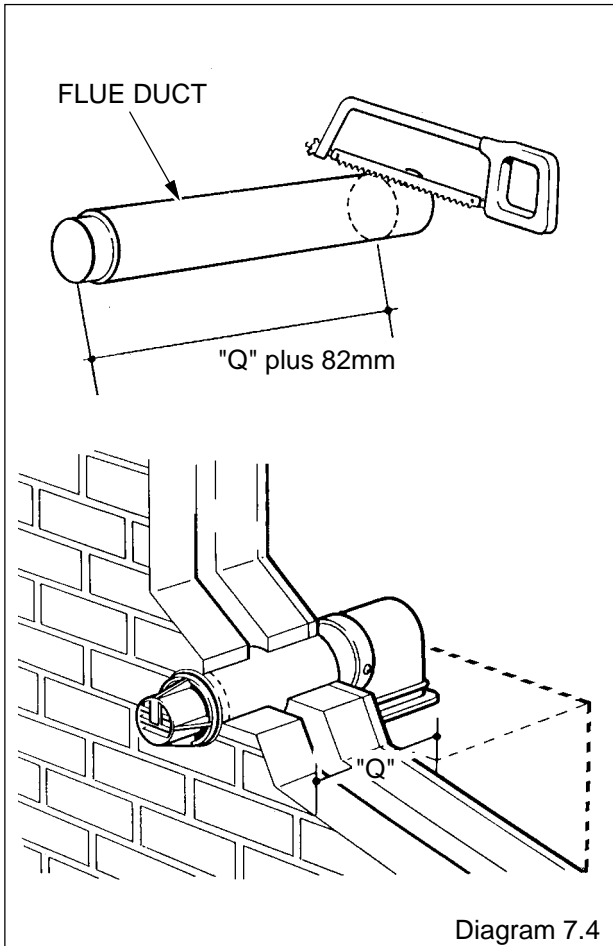

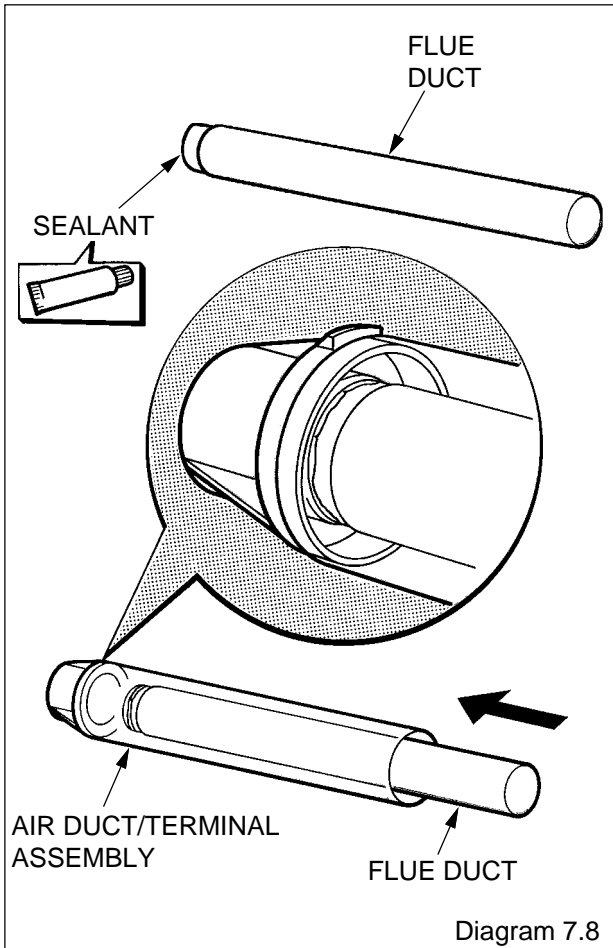

4080 S

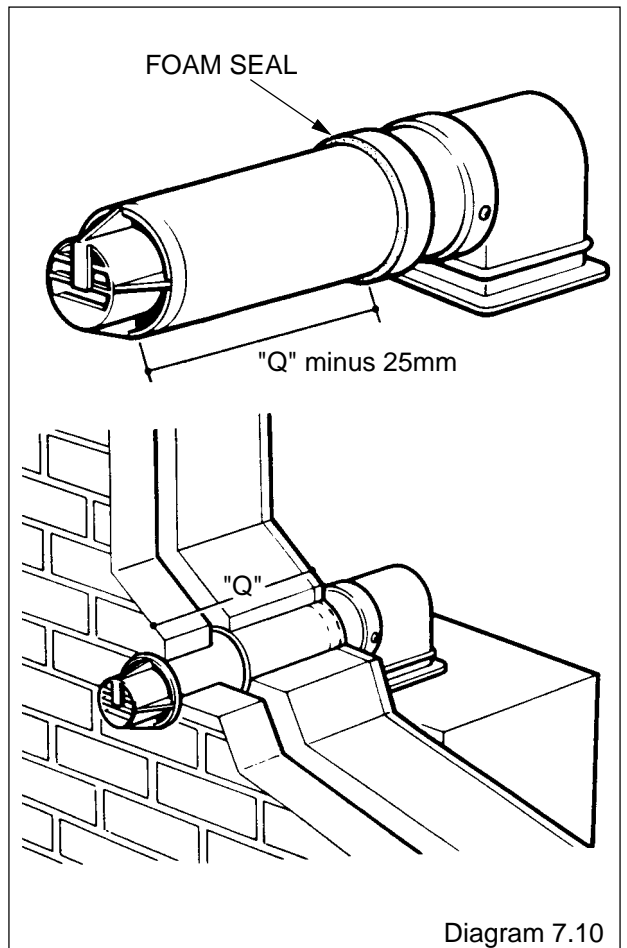

4049 S

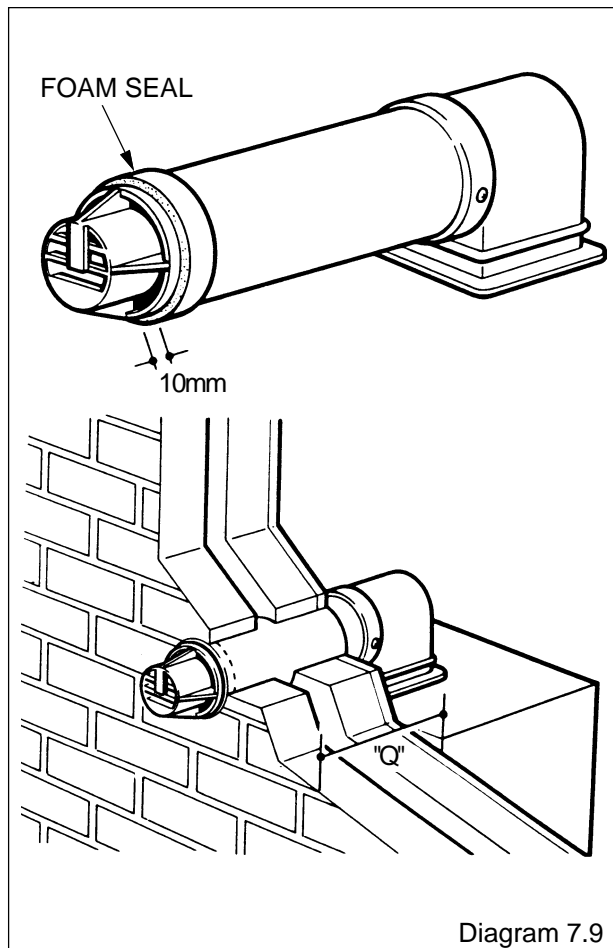

4048 S

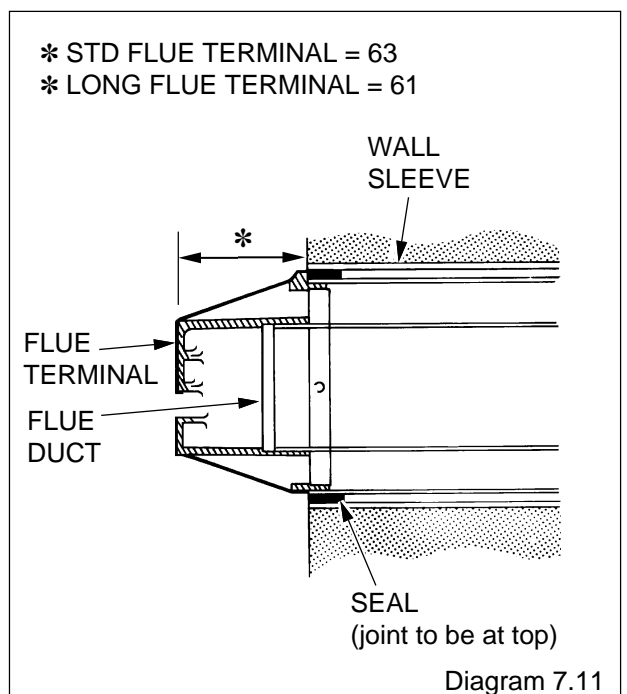

4041 S

8 Gas Connection

Make the gas connection to the gas service cock, see diagram 8.1.

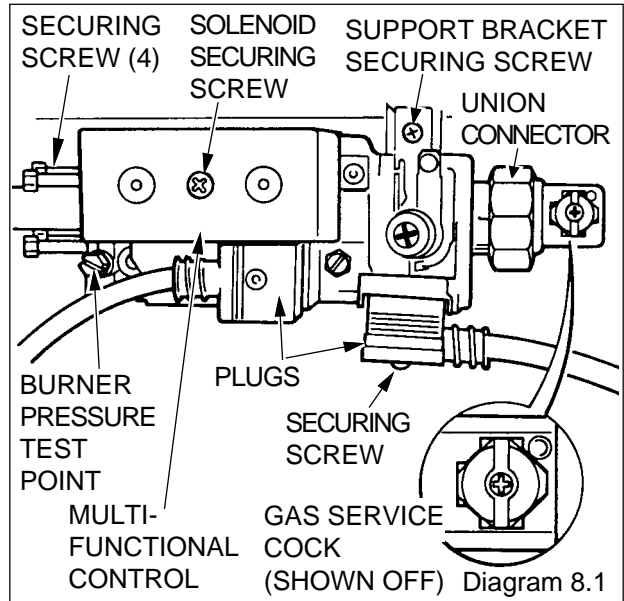

9 Electrical Connection

NOTE:

WARNING: This boiler must be earthed.

Remove the screws as diagram 9.1.

Pull the control box forwards to release from the rear slot, allow to pivot and place into position as shown in diagram 9.1.

Using PVC insulated cable to the current issue of BS6500 Table 16, and of a suitable length, thread the cable through the small cable clamp and connect to the appropriate terminals, see diagram 9.2.

Standard colours are, brown - live,
 blue - neutral,
 green/yellow - earth.

The mains cable outer insulation must not be cut back external to the cable clamp.

When making connections, make sure that the earth conductor is made of a greater length than the current carrying conductors, so that if the cable is strained the earth conductor would be the last to become disconnected.

It is essential that the polarity is correct.

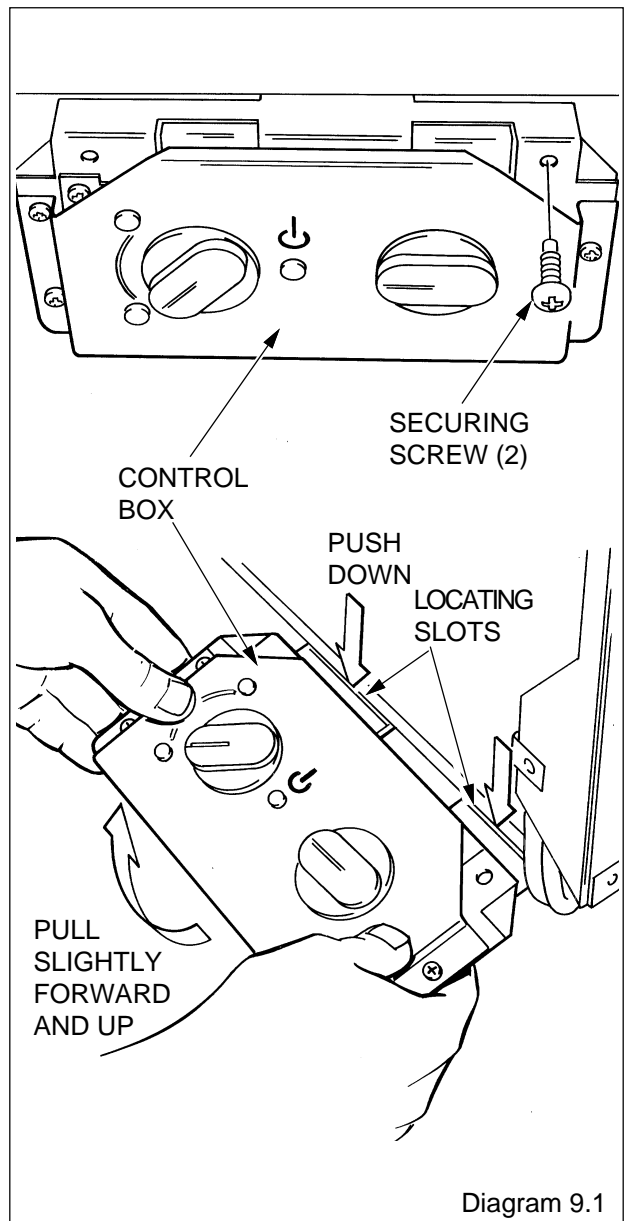

9.1 Pump and External Controls Connection

The pump must be connected directly to the control box, as shown in diagram 9.2.

Any external controls must only be connected to terminals 1 and SL, after removing red link.

Thread the cable(s) through the large cable clamp in the side of the control box.

9.2 Testing - Electrical

Checks to ensure electrical safety should be carried out by a competent person.

In the event of an electrical fault after installation of the system, preliminary electrical system checks as below should be carried out:

1. Test insulation resistance to earth of mains cable.
2. Test the earth continuity and short circuit of all cables.
3. Test the polarity of the mains.

The installer is requested to advise and give guidance to the user of the controls scheme used with the boiler.

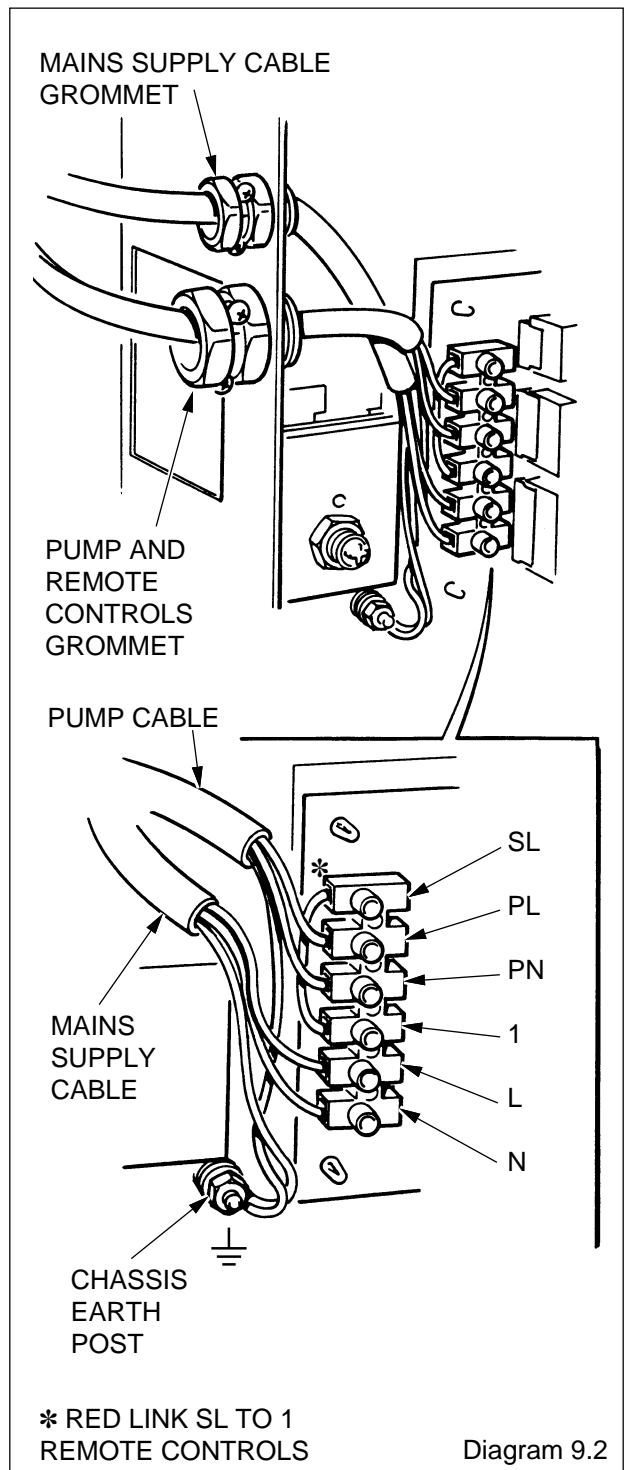

10.1 Preliminaries-All Systems

Commissioning should be carried out by a competent person in accordance with current issue of BS6798.

Make sure that the system has been thoroughly flushed out with cold water without the pump in place.

Refit the pump, fill the system with water, making sure that all the air is properly vented from the system and pump.

Before operating the boiler check that all external controls are calling for heat.

10.2 Sealed Systems

Fill the system until the pressure gauge registers 2.7bar (40lbf/in²). Clear any air locks and check for leakage.

Check the operation of the safety valve, preferably by allowing the water pressure to rise until the valve lifts. This should be within +/-0.3bar (+/-4.3lbf/in²), of the preset pressure. Where this is not possible a manual check should be carried out.

Release the cold water to initial design pressure.

10.3 Initial Lighting, Testing and Adjustment

WARNING: The multifunctional control, fan and control box operate on MAINS voltage, terminals will become live.

Check that the mains electrical supply to the boiler is switched off and that the control thermostat is turned to "O", see diagram 10.1.

For future reference stick the self adhesive adhesive arrow indicator, from the loose items pack, to the data label against the rating that the boiler is going to be set to.

Turn on the supply at the gas service cock.

Loosen the burner pressure test point screw and fit a suitable pressure gauge, see diagram 8.1.

Turn the electrical supply on to the boiler and check that all remote controls are calling for heat.

The orange demand light will come on, see diagram 10.1.

Turn the left hand switch to "High" flame.

Turn the control thermostat knob, at the right, clockwise to any position between "MIN" and "MAX", see diagram 10.1. The maximum setting is about 82oC (180°F).

The boiler will not light between "O" and "MIN".

The boiler lighting operation is now automatic.

The fan operates, followed by an ignition spark until the burner lights on "Low" flame after a short period it will go to "High" flame the green light is on.

The burner will remain alight until switched off by the control thermostat or other remote control.

The automatic lighting sequence will operate again when heat is required.

10.4 Testing - Gas

With the boiler on proceed as follows:

Test for gas soundness around the boiler gas components using a suitable leak detection fluid, in accordance with the current issue of BS6891.

Check the burner pressure at least 10 minutes after the burner has lit, refer to Data label.

If the main burner pressure requires adjustment, remove the clear plastic screw cover for access to the adjustment nuts, see diagram 10.2.

The outer, brass nut, controls the main (high) burner pressure.

The centre, plastic posidrive screw controls the "Low" burner pressure.

The centre, plastic posidrive screw must be held in position whilst adjusting the main (high) burner pressure, brass nut.

After adjustment the low pressure must be checked, by turning the "high/low" to "low" setting.

Turn the control thermostat knob to "Off".

Remove the pressure gauge from the test point and refit the screw, making sure that a gas tight seal is made.

When the control thermostat is turned to "Off", by hand, wait at least 30 seconds before turning "On" again.

There may be an initial smell given off from the boiler when new, this is quite normal and it will disappear after a short period of time.

Refit the electrical controls box.

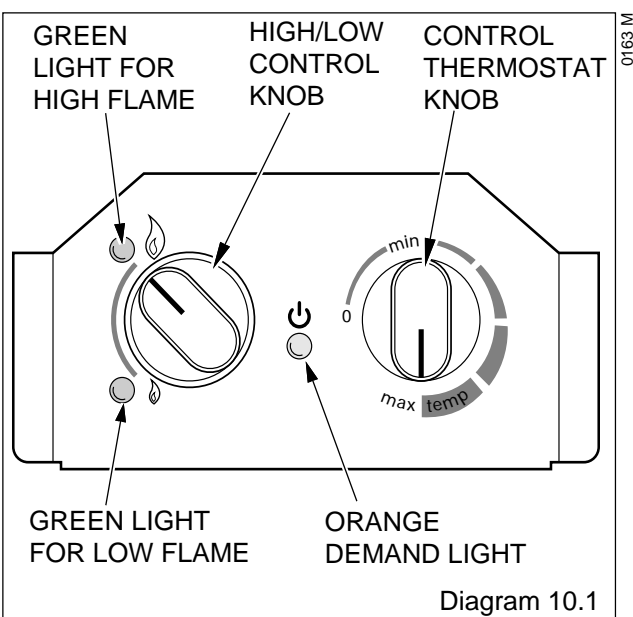

10.5 Heating System

Check that all remote controls are calling for heat.

Allow the system to reach maximum temperature and examine for water leaks. The boiler should then be turned off and the system drained off as rapidly as possible whilst still hot.

Refill the system, vent and again check for water soundness.

For sealed water systems adjust to initial design pressure. The set pointer on the pressure gauge should be set to coincide with the indicating pointer.

The overrun thermostat will keep the pump running when the boiler shuts down, so long as the temperature within the boiler is above a predetermined level.

When commissioning the system the boiler should be fired with the bypass fully closed on full service, that is, central heating and domestic hot water. The system should then be balanced, adjusting the pump and lockshield valves as necessary to achieve flow rates, refer to Section 2.4.

Having achieved a satisfactory condition, operate the boiler with the bypass closed on minimum load, normally central heating only with one radiator operating in the main living area. The valve should be opened gradually to achieve the appropriate flow rate as quoted in Section 2.4. If necessary readjust the pump.

Under NO circumstances should this valve be left in the FULLY Closed position.

10.6 Condensate Check

After 30 minutes of running, turn the boiler off and remove the inner case.

Check that there are no condensate leaks from the fan outlet/flue elbow or fan inlet/flue hood joints. Also check for leaks from the condensate drainage system.

10.7 Operational Checks

Adjust the control thermostat and any system controls to their required settings and set “high/low” switch to “high”.

Do not attempt to adjust the thermostat calibration screw.

Operate the boiler again on full service and check that the balancing is satisfactory, making further adjustments as necessary to the system, radiator valves and bypass.

There must be no pumping over of water or entry of air at the vent above the feed and expansion cistern.

If thermostatic radiator valves are fitted care must be taken to make sure that there is an adequate flow rate through the boiler and bypass when the valves are closed. For guidance on the use of thermostatic radiator valves refer to the current issue of BS7478 and British Gas Publication “Guidance Notes for Installation of Domestic Condensing Boilers”.

To check the operation of the flame supervision device, with the burner alight, turn gas service cock to “Off” the burner will go out. There will be one attempt to relight, indicated by a 5 second ignition phase.

Wait 30 seconds.

Turn the gas cock to “ON” and the burner should NOT relight.

Turn the control thermostat knob to “OFF” and then “ON” again and the burner WILL now relight.

Turn “high/low” switch to “low” and observe low flame, then return switch to “high”.

Refit the outer case, see diagram 5.2 and secure the case with the screws from the fittings pack.

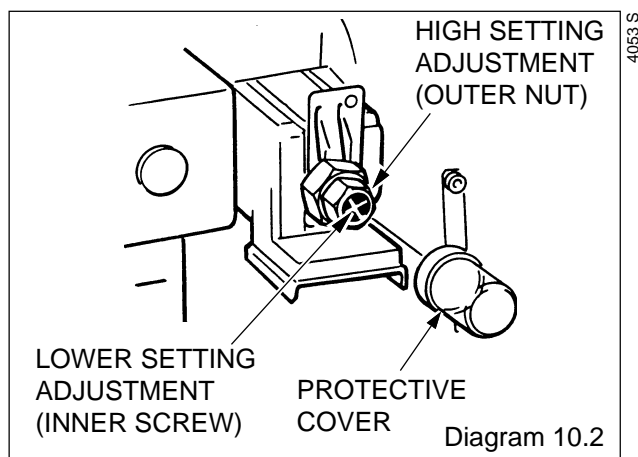

11 User Information

NOTE:

Instruct and demonstrate the efficient and safe operation of the boiler, heating system and if fitted the domestic hot water system.

Advise the user that the Energysaver, like all other condensing boilers will produce a plume of condensation from the flue terminal in cold weather, this is quite normal.

Show the user the position of "Lighting Instructions" - refer to Instructions for Use.

Advise the user that for summer use the "high/low" switch can be turned to "low".

Advise the user of the precautions necessary to prevent

damage to the system and building in the event of the heating system being out of use during frost and freezing conditions.

Advise the user, that to ensure the continued efficient and safe operation of the boiler it is recommended that it is checked and serviced at regular intervals. The frequency of servicing will depend upon the particular installation conditions and usage, but in general once a year should be enough.

Draw attention, if applicable, to the current issue of the Gas Safety (Installation and Use) Regulations, Section 35, which imposes a duty of care on all persons who let out any property containing a gas appliance.

It is the Law that servicing is a carried out by a competent person.

Reminder, leave these instructions with the user.

12 Servicing

NOTES:

To ensure the continued efficient and safe operation of the boiler it is recommended that it is checked and serviced at regular intervals. The frequency of servicing will depend upon the particular installation and usage, but in general once a year should be enough.

It is the Law that any servicing is carried out by a competent person.

Note. For obtaining a products of combustion reading use the connection on top of the boiler, see diagram 6.1.

Should the gas pressure need adjusting refer to Section 10.4.

Isolate the boiler from the electrical supply.

Before starting a service, remove the casing, refer to diagram 5.1.

Turn the gas supply off at the gas service cock, see diagram 8.1.

Unless stated otherwise, parts removed for servicing should be replaced in the reverse order to removal.

After completing any servicing of gas carrying components, ALWAYS test for gas soundness and carry out functional check of controls.

Also check for condensate leaks at fan outlet/flue elbow and fan inlet/flue hood joints.

It should be noted that the burner is water cooled and a system drain down is necessary if the burner is removed.

12.1 Heat Exchanger Cleaning

Remove the inner case cover, see diagram 5.3.

Remove the bypass heat shield and air baffle, see diagram 12.1.

Note. The flue hood top will "spring" up.

Disconnect the fan air pressure tubes, combustion sampling tube, electrical connections and remove the three fan securing screws, fan securing bracket, then fan and the flue hood.

Note. On reassembly it is suggested that the two top securing screws for the bypass heat shield and the flue hood be partially engaged before fitting of the bypass heat shield, see diagram 12.3.

Carefully remove the combustion chamber front panel, see diagram 12.4.

Remove the loose baffle from the condensing section, see diagram 12.5.

Place a container under condensate drain trap, see diagram 12.8, and remove red cap.

Flush loose debris from secondary heat exchanger with water poured from above, and allow the water to drain through the flexible condensate tube at the right hand side of heat exchanger into the container.

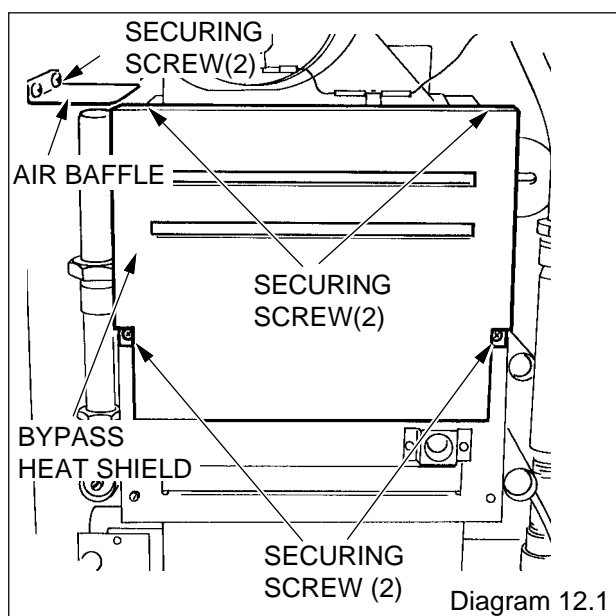

Check that this tube is not partially blocked and the water runs freely.

If there is any build up of debris in the condensate trap, the trap should be removed and flushed out.

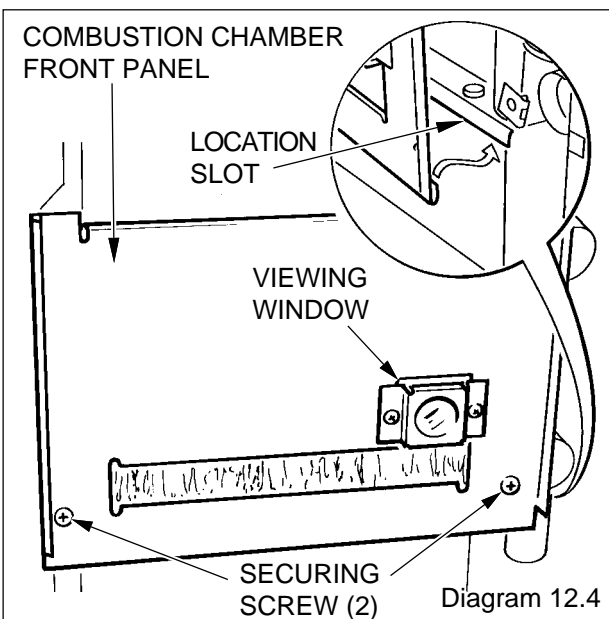
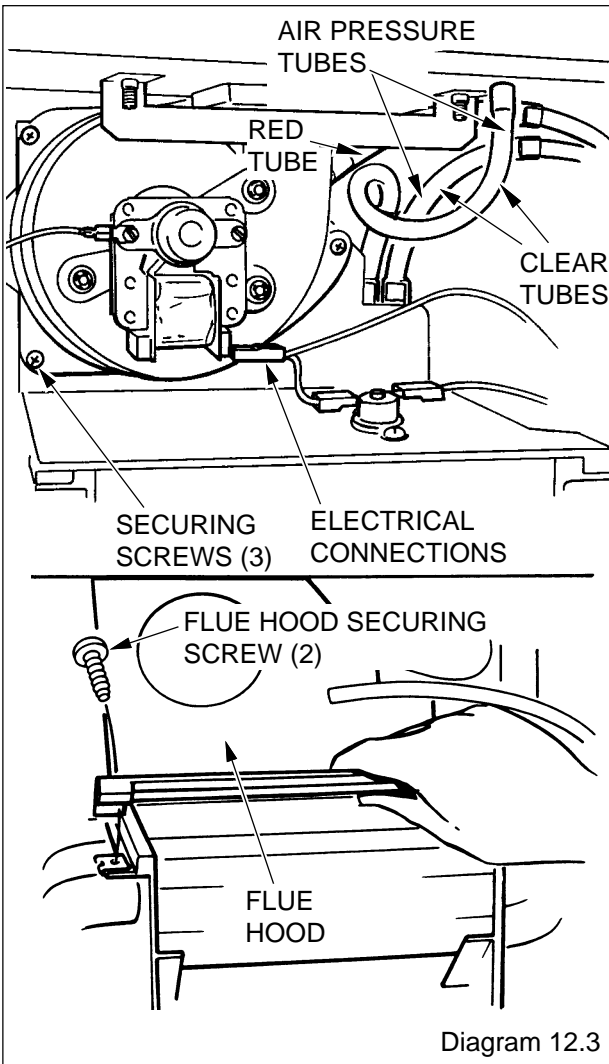

Important: With use a white oxide coating will form on the aluminium parts - this should only be removed if the coating is blocking the gaps between the fins.

When cleaning take care that the water does not overflow the condensate catchment tray.

Place a sheet of paper over the burner, see diagram 12.6.

Clean the primary heat exchanger, with a suitable soft brush, see diagram 12.6.

Brush from back to front NOT left to right.

Do not use a brush with metallic bristles.

Remove the paper and any debris.

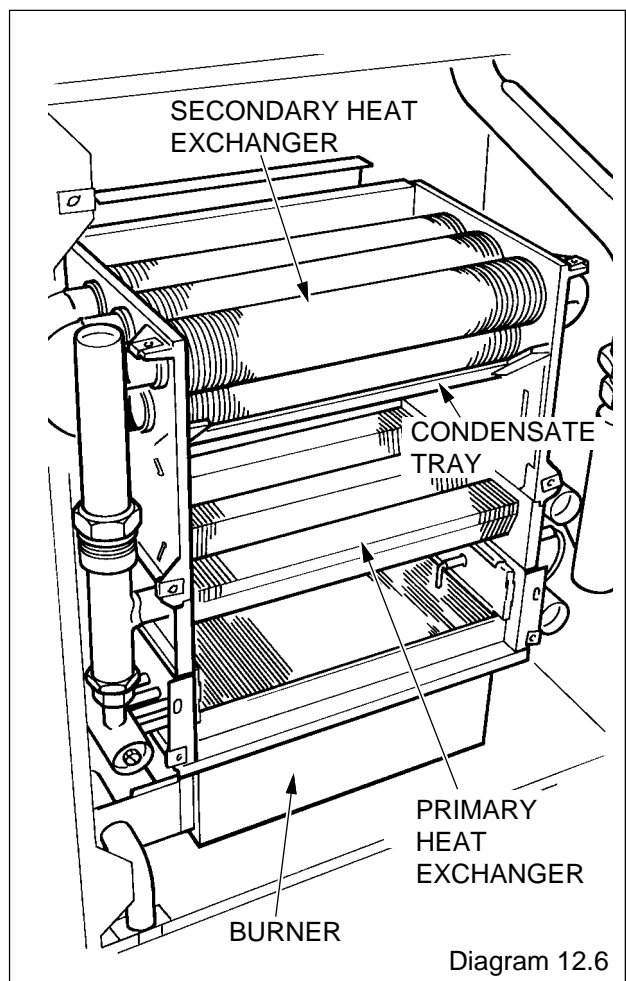
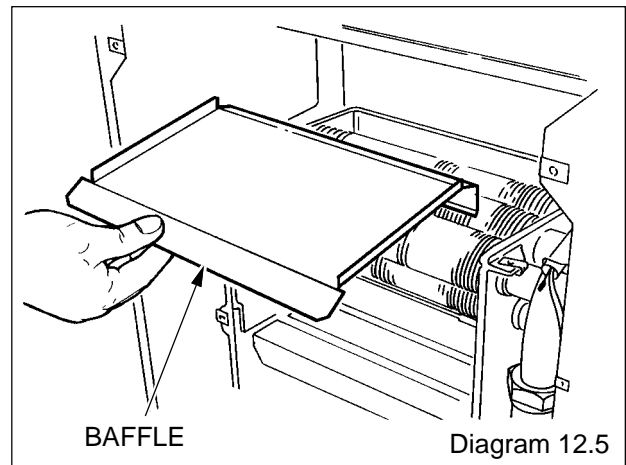

12.2 Burner

Clean the fins of the burner with a suitable soft brush, any debris can be allowed to fall into the mixing chamber.

Do not use a brush with metallic bristles.

Note: The burner is water cooled and a system drain down is required if removing.

12.3 Injector

Remove the injector by releasing the three screws at the injector manifold burner box, the two screws at the inner case base sealing plate and the four screws at the multifunctional valve, see diagram 12.7.

Make sure that the "O" ring is in place in the flanged connection when refitting.

Clean the holes by blowing through.

Do not use a wire or sharp instrument on the holes.

12.4 Spark Electrode

Remove the silicone sleeving and disconnect the ignition/sensing lead, see diagram 12.9.

Remove the two securing screws.

Withdraw the electrode taking care not to damage the insulation material. Inspect and clean taking care not to damage the ceramic body.

When replacing make sure that the spark gap is as shown.

12.5 Condensate Drain

Remove the cap at the base of the condensate drain trap, see diagram 12.8 and carefully flush through, from the condensate collecting tray, diagram 12.6, taking care not to allow any water to overflow the tray.

When refitting the cap make sure a water tight seal is made.

12.6 Operational Checks

After completing a service, before fitting the casing, check the inner case seal to ensure that it is in good condition, renew if necessary.

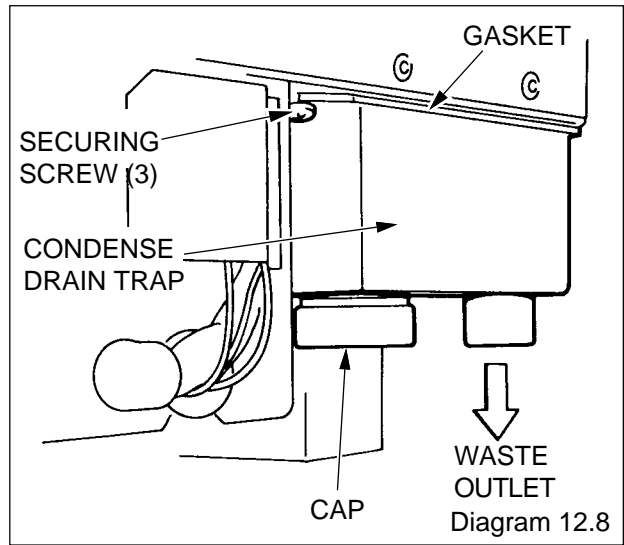

4060 S

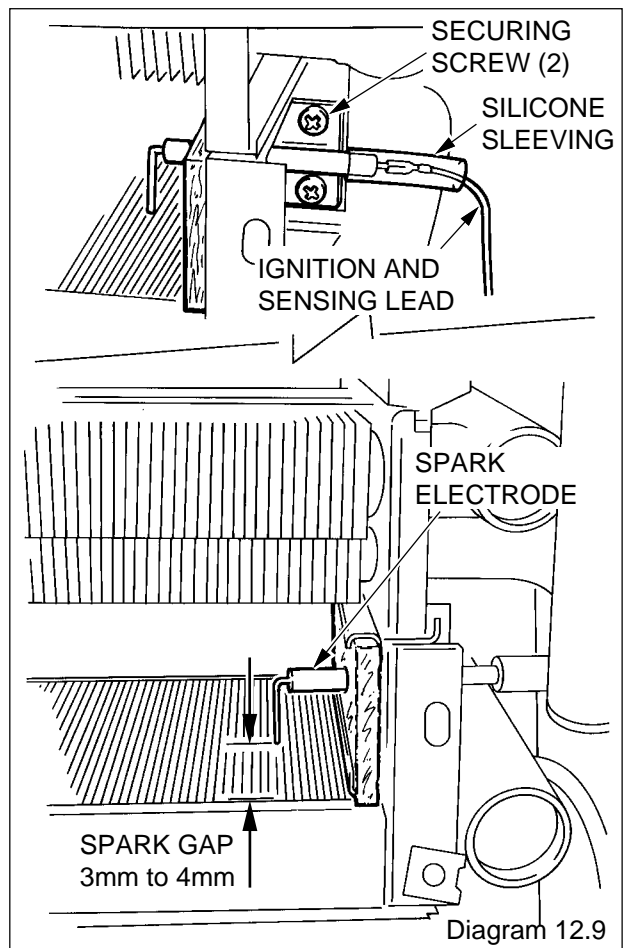

4375 S

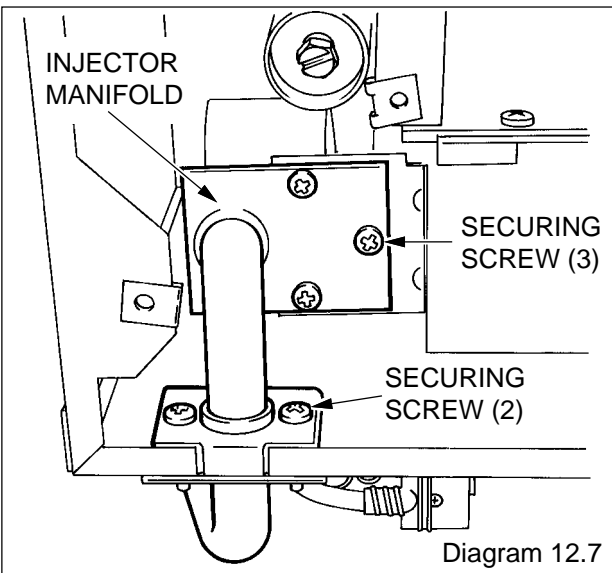

4374 S

13.1 Electrical

Important. On completion of the Service/Fault Finding task which has required the breaking and remaking of the electrical connections the earth continuity, polarity, short circuit and resistance to earth checks must be repeated using a suitable multimeter.

Refer to Fault Finding, diagram 13.1, Wiring, diagram 13.2 and Functional Flow diagram 13.3.

Note. Failure of an indicator light does not warrant the replacement of an otherwise satisfactory part.

13.2 Electrical Supply Failure

Failure of the electrical supply will cause the burner to go out.

Operation will normally resume on restoration of the electrical supply. If the boiler does not relight after an electrical supply failure the overheat device may need resetting.

To reset, pull the information panel forwards on the underside of the boiler and press the reset button, see diagram 13.4.

If the cutoff operates at any other time press the reset button and the burner should relight. If the fault persists refer to Fault Finding Chart.

There is a further cutoff, mounted on the flue hood, see diagram 13.5, which may need resetting.

13.3 Condensate Sensor

Refer to fault finding chart.

The boiler is fitted with a safety device to prevent the boiler from working if the condensate drain pipe gets blocked.

Remove the condensate drain cap, diagram 14.2.

If condensate is backing up to the sensor position, the drain is blocked and it must be cleared before the boiler will work. Inspect external condensate drain pipe and clear away any debris or ice. Release ice blockage by using warm cloths on the pipe.

PUMP OVERRUN OPERATION

The control thermostat has a pump overrun facility built into it, when the control thermostat is set at maximum only, the pump overrun will keep the pump running to allow the boiler to cool down after which it will stop, providing the remote controls are NOT calling for heat.

FAULT FINDING

Turn boiler control thermostat to maximum, with the remote controls calling for heat, does the pump continue to run after the appliance has shut down on boiler control thermostat ?

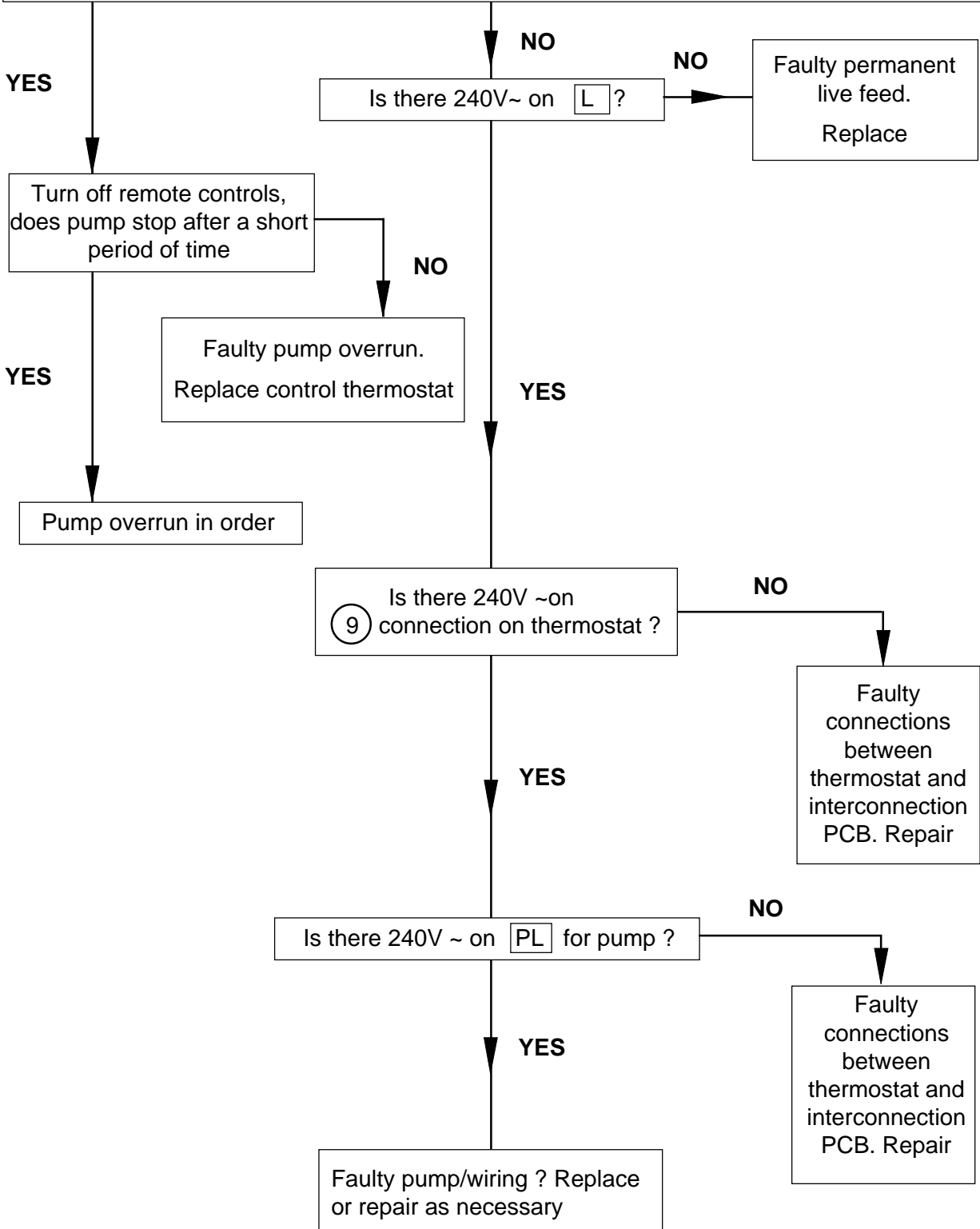

Before detailed checking of electrical components ensure that remote controls are calling for heat. Check that the gas supply is free of obstructions and purged of air. Check the overheat thermostat and fluehood thermostat have not operated. Isolate the electrical supply and physically check ALL cables, connections and the printed circuit board (PCB) fuse. Check the air tubes to air pressure switch.

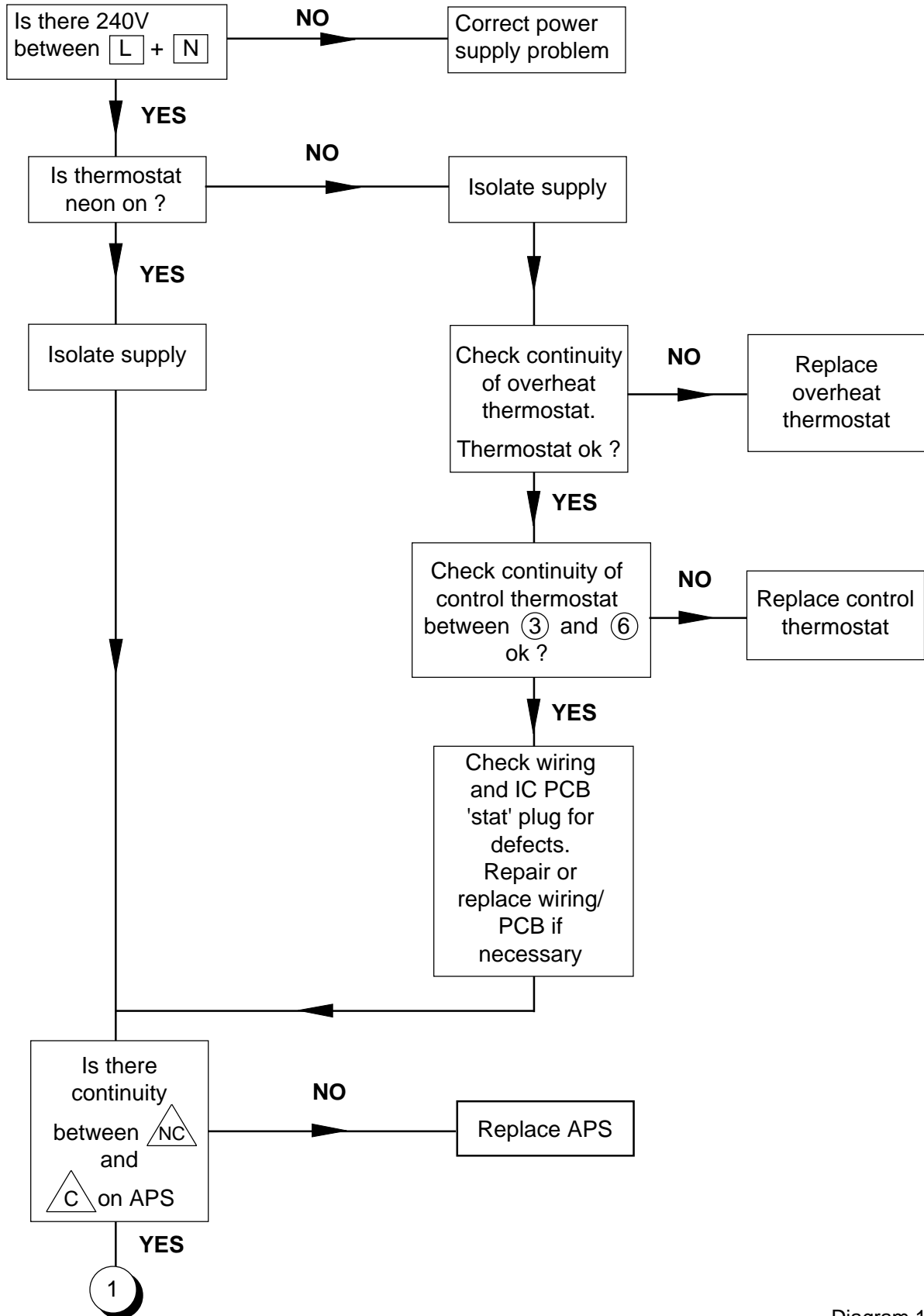

Diagram 13.1

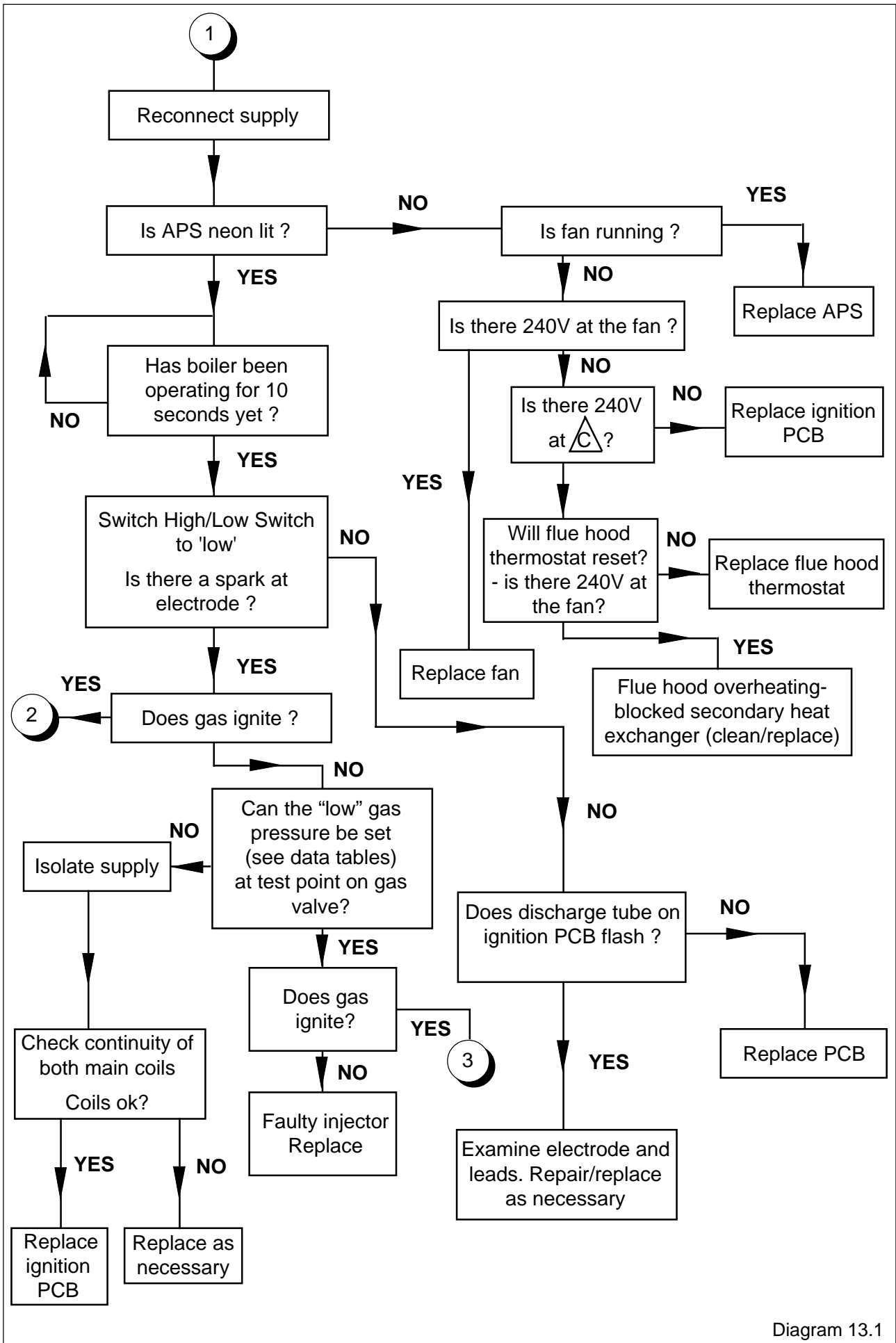

Diagram 13.1

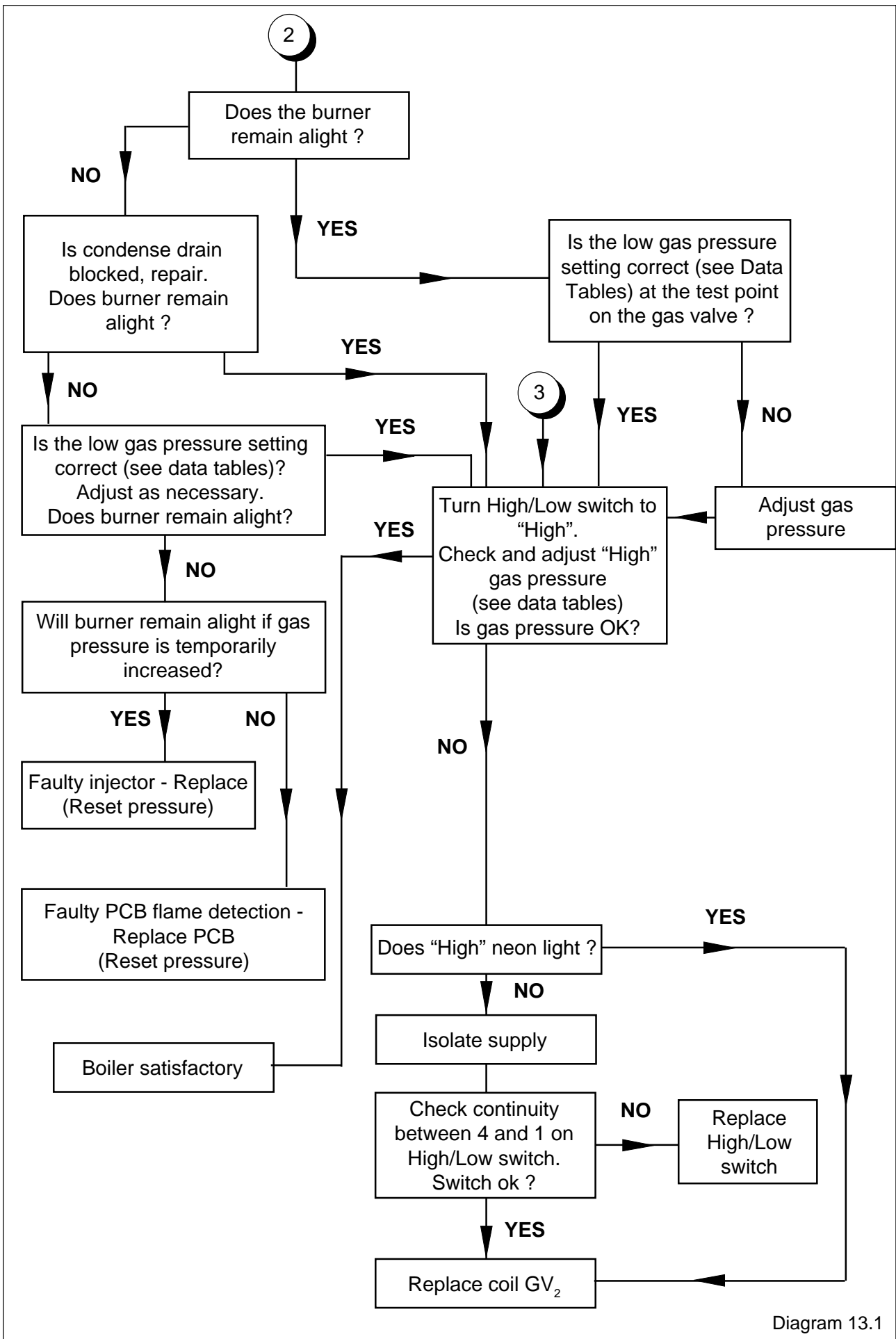

Diagram 13.1

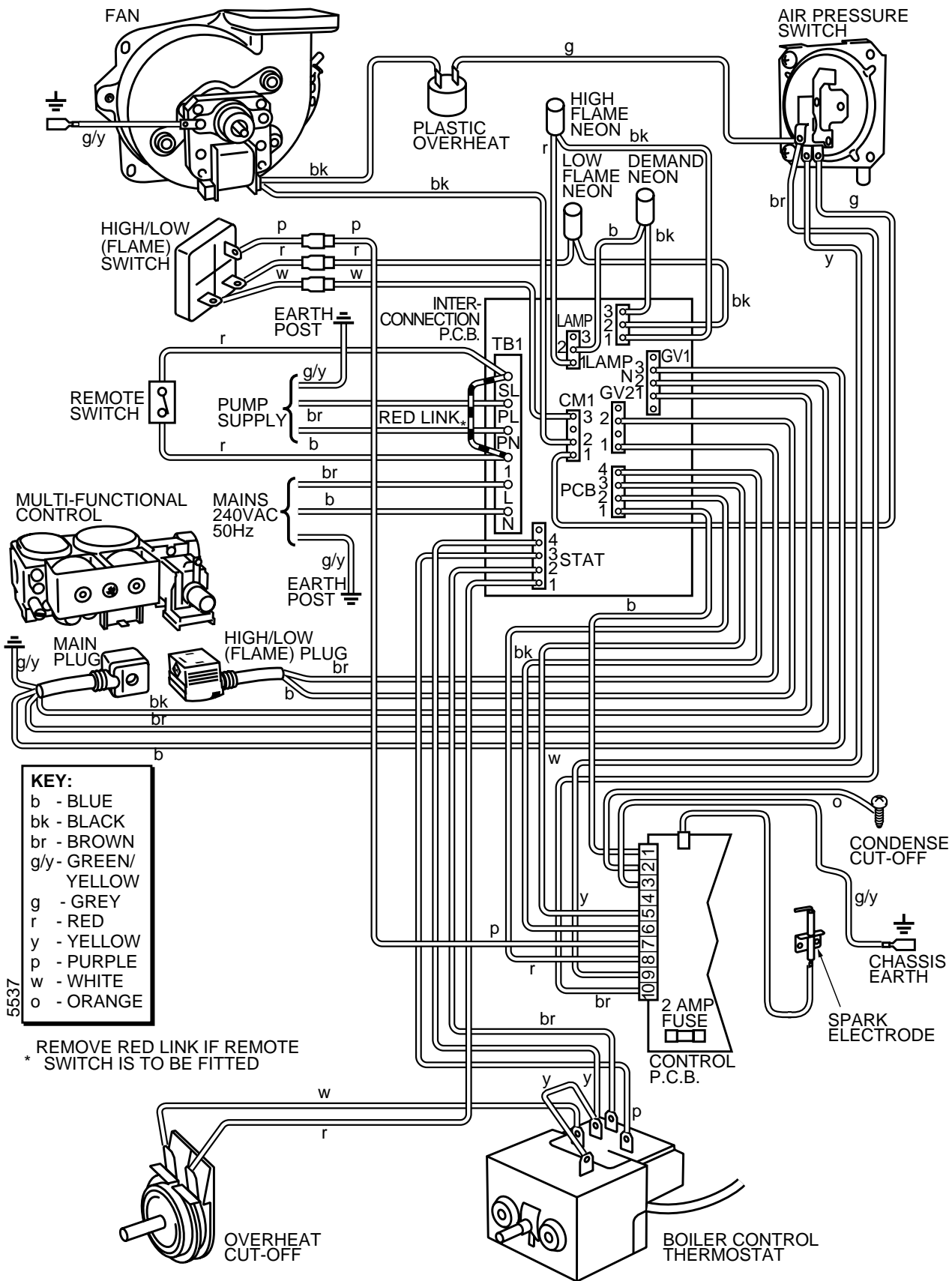
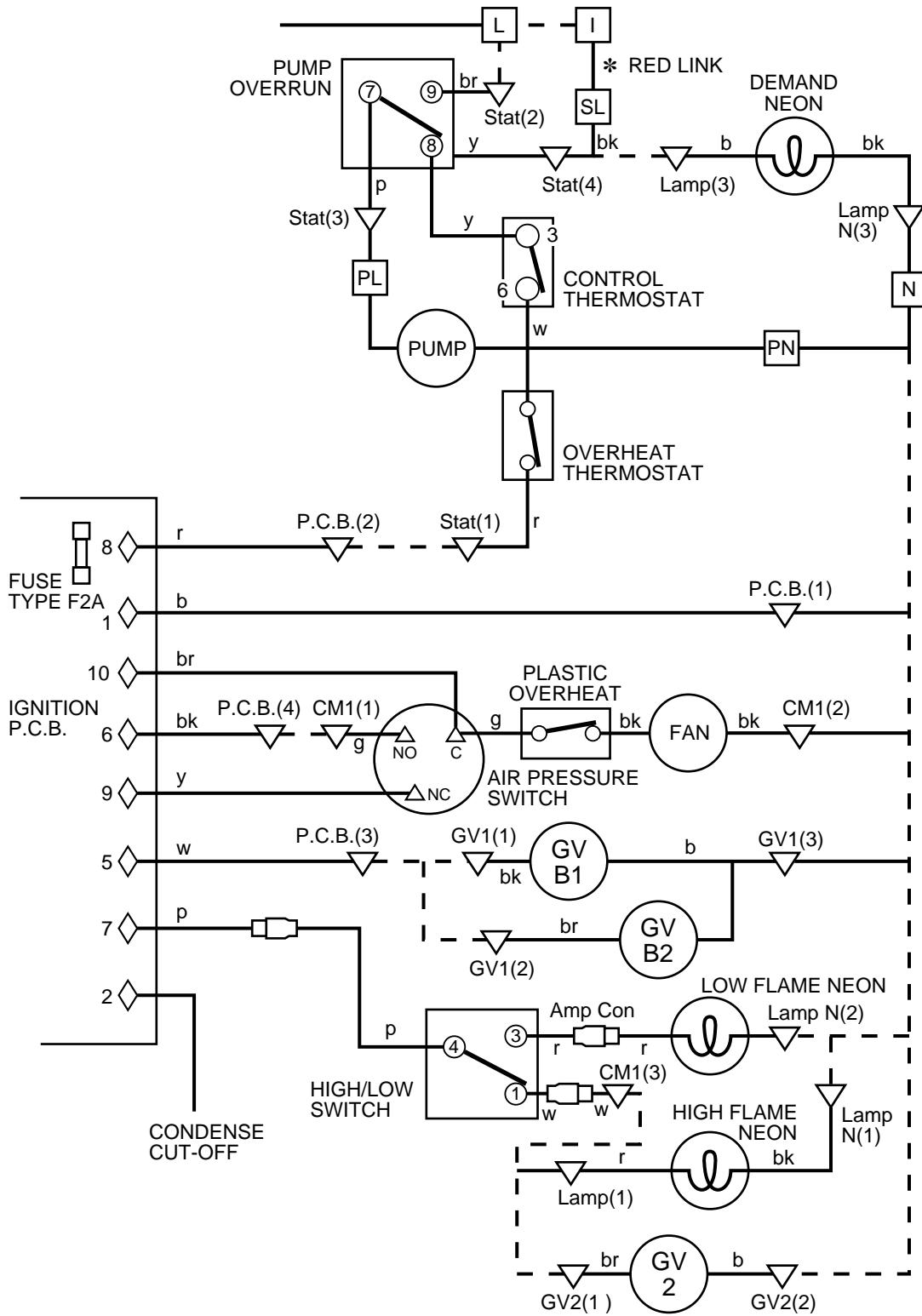

Diagram 13.2



KEY:
 r - RED
 br - BROWN
 p - PURPLE
 b - BLUE
 bk - BLACK
 y - YELLOW
 w - WHITE
 g - GREY

▽ I.C. P.C.B. CONNECTIONS: ie STAT (Pin No. from bottom)
 □ MAIN TERMINAL STRIP CONNECTIONS
 ○ CONTROL THERMOSTAT CONNECTIONS
 ◇ PRINTED CIRCUIT BOARD CONNECTIONS
 * RED LINK MAY HAVE BEEN REMOVED TO FIT REMOTE CONTROLS

Diagram 13.3

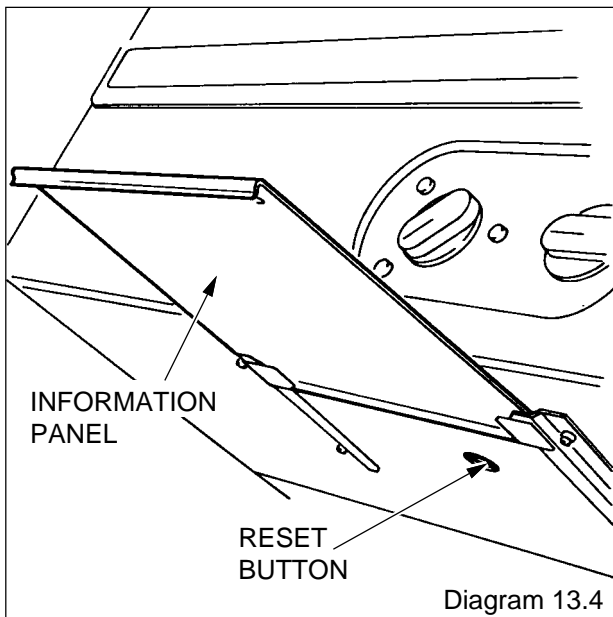

4062 S

Diagram 13.4

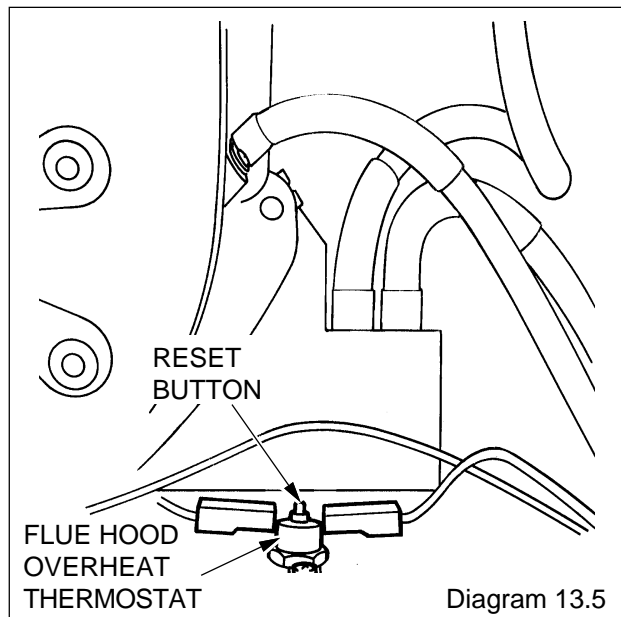

4067 S

Diagram 13.5

14 Replacement of Parts

NOTES

Replacement of parts must be carried out by a competent person.

Before replacing any parts isolate the boiler from the electrical supply and turn the gas supply off at the gas service cock, see diagram 8.1.

Unless stated otherwise, all parts are replaced in the reverse order to removal.

After replacing any parts always test for gas soundness and if necessary carry out functional check of controls.

For the following the front case and inner case cover will need to be removed, diagrams 5.2 and 5.3.

14.1 Spark Electrode

Replace as described in Section 12.4.

14.2 Ignition Lead: diagram 14.2

Release the control box as Section 9.

To disconnect the ignition lead from the control board, remove the PCB from the mountings pegs, the front two have detachable grips, the rear two are plain supports.

When refitting lead make sure that there is enough length through the gland plate assembly.

Condensate Sensor: diagram 14.2

Refer to the relevant parts of section 14.2 to remove the screw.

The sensing screw is fitted to a push fit cap which can be levered off for easy access.

Note. The condensate flexible tube is a push-fit and can be removed from the condensate drain cap to improve access to the screw.

When replacing the cap make sure that it is firmly in place and that the ring tag is pointing away from the casing side.

14.3 Printed Circuit Boards (PCBs): diagram 14.3

Release the control box as Section 9.

Control PCB: diagram 14.3 (top)

Disconnect the electrical plug on the board.

Release from its two support posts and carefully pull the board away noting that the ignition lead is still connected.

It may be necessary to hold some of the wires above the PCB clear with an electrical screwdriver on removal or refitting.

Release and carefully pull the board away from its supports, noting that the ignition lead is still connected.

Disconnect the ignition lead.

Interconnecting PCB: (ICB) diagram 14.3 (bottom)

Disconnect the electrical plugs and cables from the terminal strip.

Release and carefully pull the board away from its supports.

When refitting refer to wiring diagram 13.2.

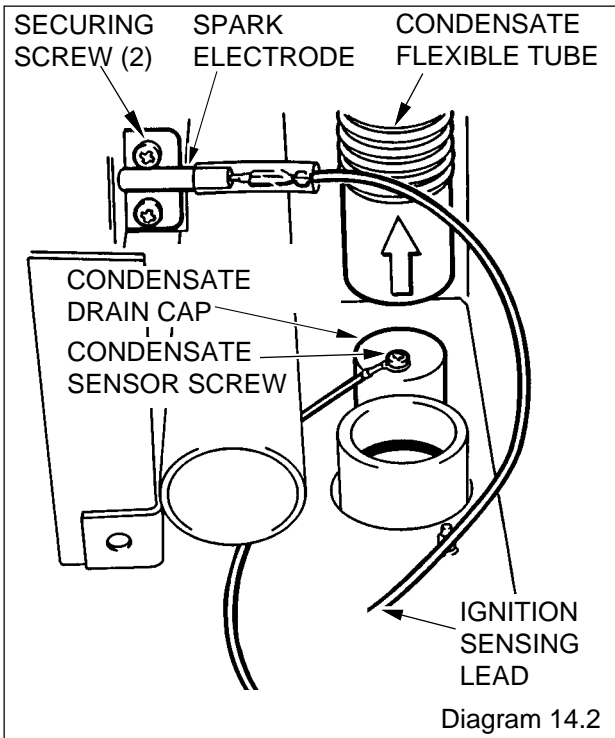

14.4 Control Thermostat and Overheat Cutoff

Release the control box, see Section 9.

Control Thermostat: diagram 14.4A and 14.4

Pull off the control thermostat and High/Low knobs.

Remove the three fascia securing screws and fascia.

Remove the electrical connections from the control thermostat body.

Remove the two control thermostat securing screws.

Release the gland plate assembly, see diagram 14.2.

Release and remove the control thermostat phial from the pocket.

Withdraw the capillary through the controls box grommet.

Slide control thermostat body away from control box.

On replacement smear the phials with the heat sink compound supplied before replacing in the phial pocket.

When refitting refer to wiring diagram 13.2.

Overheat Cutoff: diagram 14.4A and 14.4

Remove the electrical connections.

Remove the locking nut.

Release and remove the overheat cutoff phial from the pocket.

Withdraw the capillary through the controls box grommet.

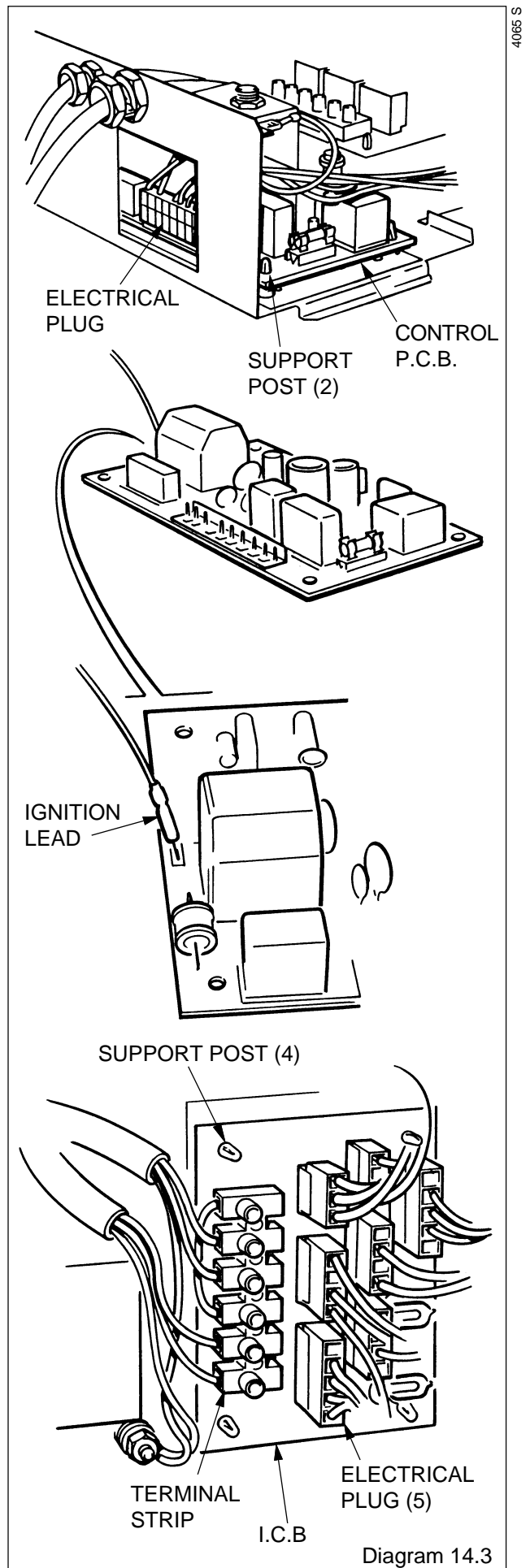

14 Replacement of Parts

4078 S

4377 S

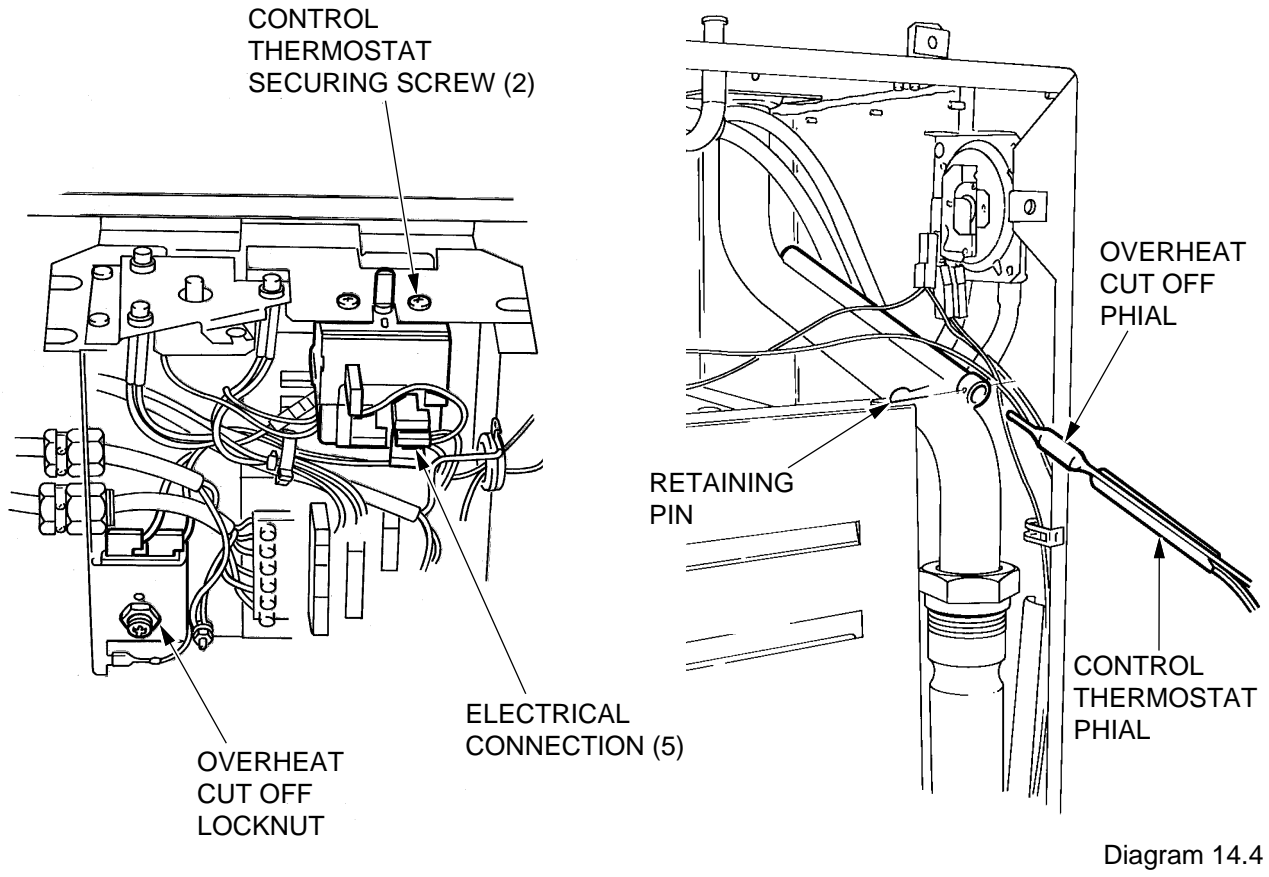

Diagram 14.4

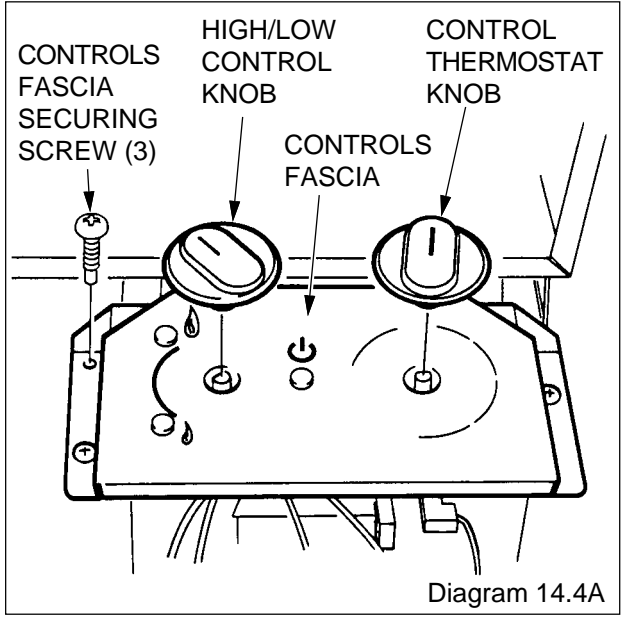

Diagram 14.4A

4086 S

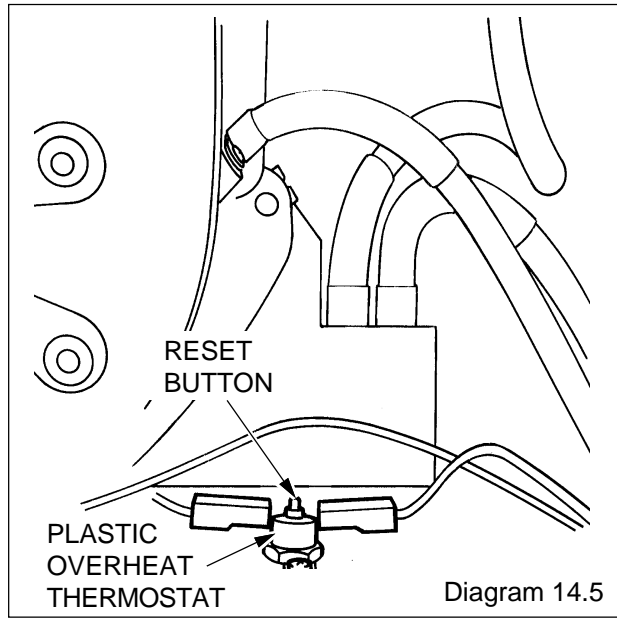

Diagram 14.5

4087 S

On replacement smear the phials with the heat sink compound supplied before replacing in the phial pocket.
When refitting refer to wiring diagram 13.2.

Neatly secure any surplus capillary.

Flue Hood Overheat Cutoff: diagram 14.5

Remove electrical connections and unfasten the screws to release.

Note: the polarity of the connections is not important.

14.5 “High/Low” Control: diagram 14.4 and 14.6

Remove the fascia as described in Section 14.4.

Remove the four screws securing the lights bracket.

Remove the locknut to release the “High/Low” control.

Disconnect the three in-line electrical connectors.

When refitting refer to wiring diagram 13.2.

14.6 Air Pressure Switch: diagram 14.7.

Remove the air pressure tubes and electrical connections.

Remove the two securing screws to release the air pressure switch.

When fitting the replacement make sure that all the air pressure tubes and electrical connections are made as shown.

14.7 Multifunctional Control: diagram 8.1.

Disconnect the screws and electrical plugs at the multifunctional control.

Support the multifunctional control and remove the four screws from the flanged connection, undo the union at the gas service cock and remove the support bracket securing screw.

Remove the multifunctional control by easing the flange and service cock apart.

Remove the union half and refit to the replacement multifunctional valve.

Use a little jointing compound on the external thread only, to ensure gas soundness.

Make sure that the new “O” ring is in place in the flanged connection is replaced.

It will be necessary to purge the pipework and multifunctional control before relighting and checking the pressure, refer to “Commissioning”.

14.8 Solenoid: diagram 8.1

Remove the solenoid securing screw and pull the solenoids and carrier forward to release.

14.9 Fan

Refer to Section 12.1 “Heat Exchanger Cleaning”.

Make sure that the earth connection is remade onto the replacement fan.

The polarity of the electrical connections is not important.

14.10 Injector

Refer to Servicing Section 12.3.

Fit new injector as shown.

Note: The replacement injector manifold is supplied complete with the gas supply pipe manifold.

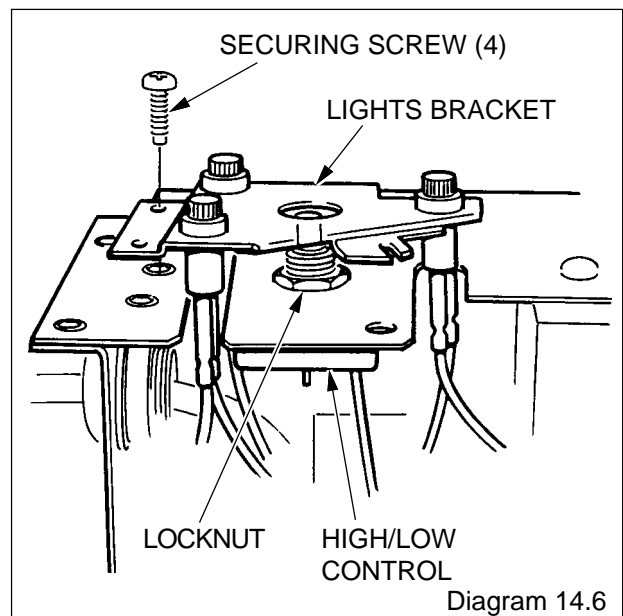

4088 S

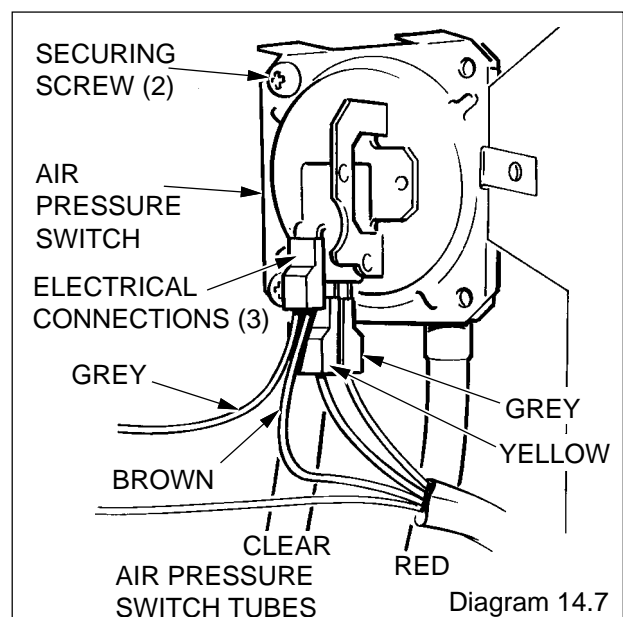

4378 S

14.11 Heat Exchanger: diagram 14.8

Note: To carryout the following operations it will be found more convenient if the whole of the heat exchanger and burner are removed as a unit.

Follow the relevant parts of Servicing Section and remove the bypass heat shield, fan/flue hood, combustion chamber front panel, heat exchanger baffle, spark electrode, injector manifold and thermostat phials.

Release the flexible tube from the condense drain trap, this is a push-fit.

Release union connections and the six securing screws, then remove the complete assembly.

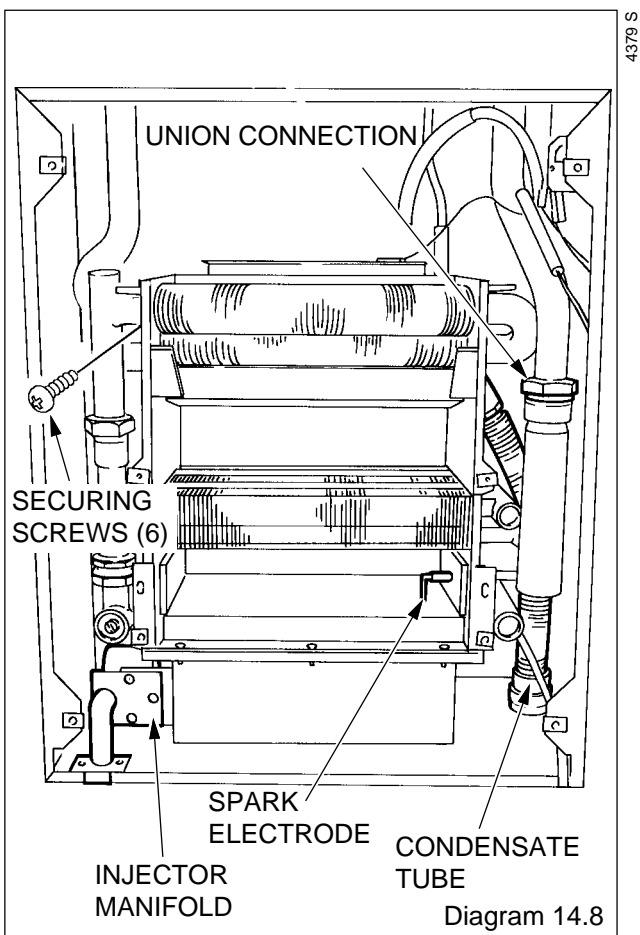

Heat Exchanger: Secondary - diagram 14.9

Disconnect the union connector.

Remove and fit the flexible hose to the replacement.

Heat Exchanger - Primary - diagram 14.10

Disconnect the three union connections.

14.12 Burner: diagram 14.9

Note: To carryout the following operations it will be found more convenient if the whole of the heat exchanger and burner are removed as a unit.

Follow the relevant parts of Servicing Section and remove the bypass heat shield, fan/flue hood, combustion chamber front panel, heat exchanger baffle, spark electrode, injector and thermostat phials.

Release the flexible tube from the condense drain trap, this is a push-fit.

Release union connections and the six securing screws, then remove the complete assembly.

Remove the insulation as Section 14.15 and retain for use in the replacement part.

Disconnect the two union connections.

Fit the insulation.

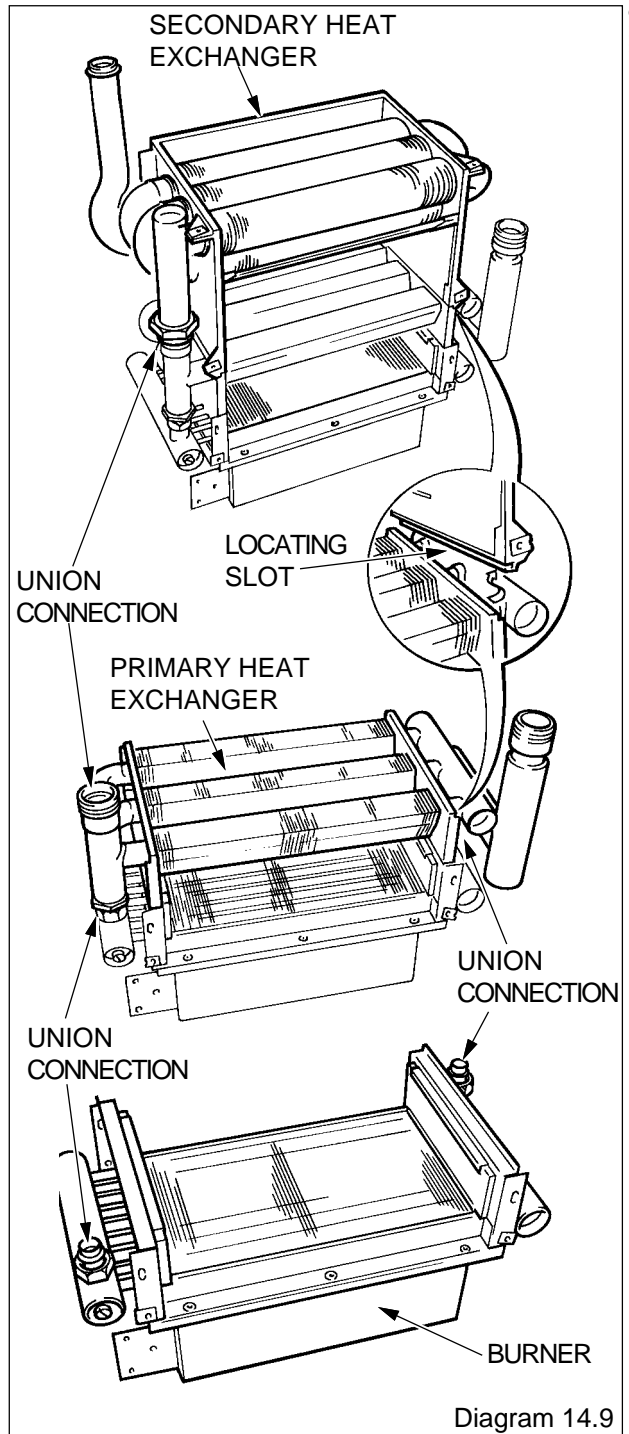

14.13 Insulation - Rear - diagram 14.10

With the heat exchangers and burner assembly removed, as Sections 14.11 and 14.12, the rear insulation pad can be removed as shown.

14.14 Insulation: Combustion Chamber Front Panel: diagram 14.11

Remove the two screws from the viewing window then slide the insulation pad out.

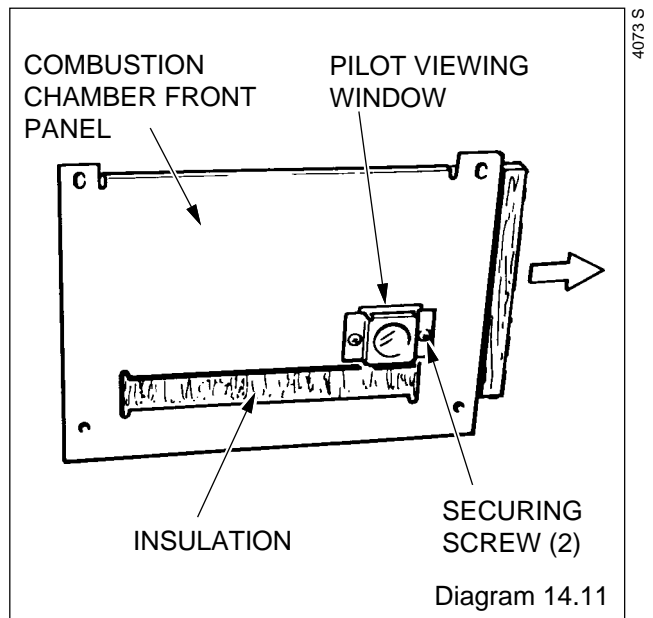
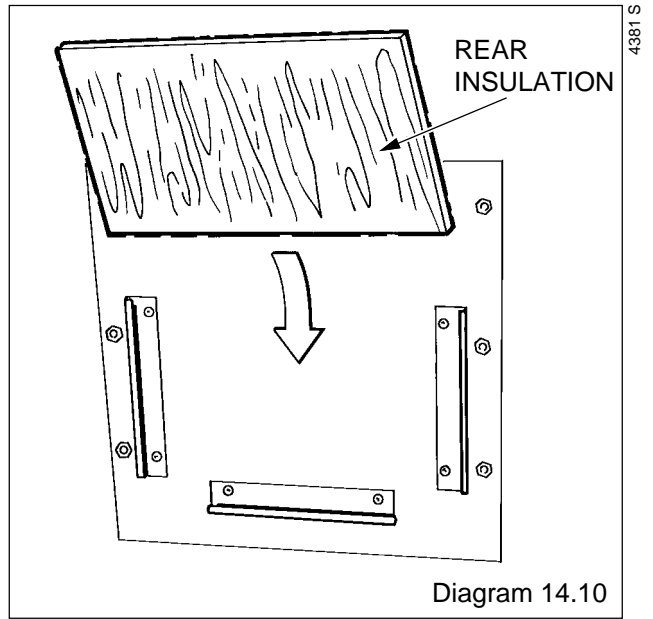

14.15 Insulation - Sides - diagram 14.12

Remove the spark electrode refer to Section 12.4.

Remove the insulation by sliding it out.

14.16 Condensate Sensor: diagram 14.13

Refer to the relevant parts of Section 14.2 to remove the screw.

The sensing screw is fitted to a push fit cap which can be levered off for easy access.

Note. The condensate flexible tube is a push fit and can be removed from the condensate drain trap to improve access to screw.

When replacing the cap make sure that the ring tag is pointing away from the casing side.

14.17 Viewing Window Glass: diagram 14.14

Remove the two screws to release the frame and glass.

When replacing take care not to damage the gasket.

14.18 Inner Case Cover Seal

When removing seal make sure that all the old adhesive is removed.

When fitting the new seal make sure that it fits correctly and has not buckled.

14.19 Fascia and Lights Assembly

Release the control box as Section 9.

Refer to the relevant parts of Section 14.5 to remove the fascia and lights bracket.

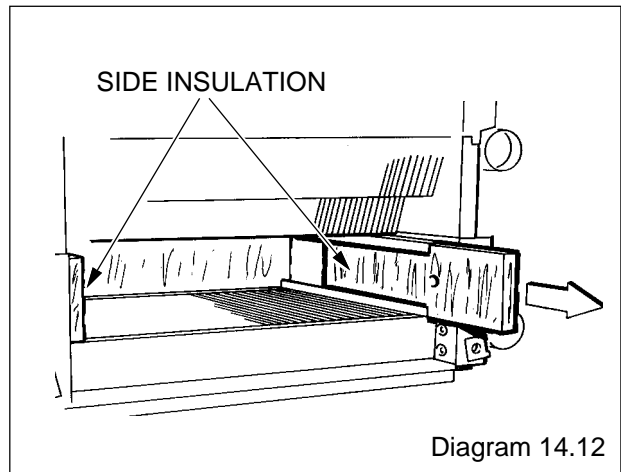

4382 S

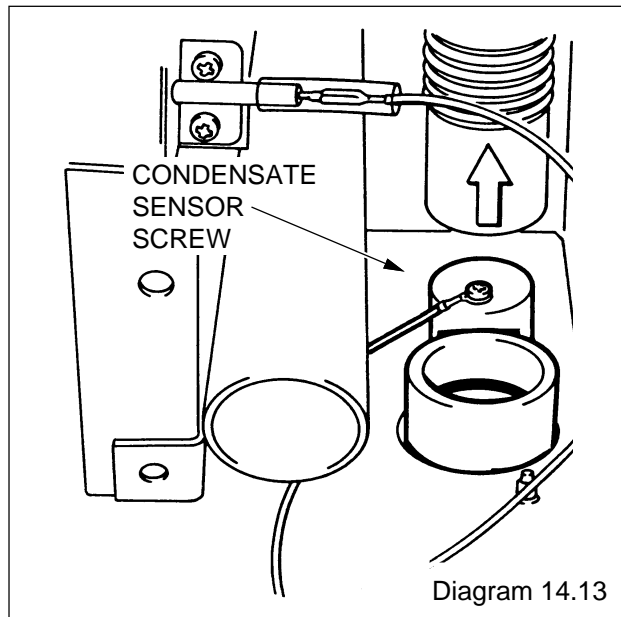

4075 S

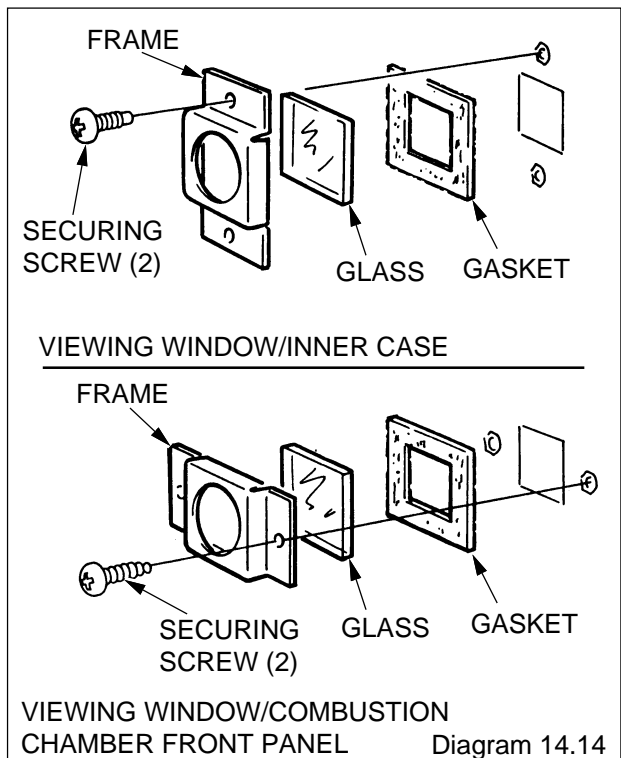

4076 S

15 Spare Parts

15 Spare Parts

When ordering spare parts, please quote the appliance name and serial number, to be found on the data label, visible when the outer casing is removed.

If ordering from the local gas undertaking also quote the GC number of the part.

Key No.	Part No.	Description	GC Part No.
1	800482	Multifunctional control	278 111
2	800375	Solenoid	278 128
3	800476	Thermostat - control	278 094
4	800477	Thermostat - over heat cutoff	278 095
4a	800466	Overheat Thermostat	278047
5	450260	High/low control	278 276
6	800467	Thermostat control knob	278 049
7	202135	Air pressure switch	313 303
8	203158P	Gas manifold assembly - 80P	278 264
9	202231	Fuse	278 292
10	208302	Sight glass	312 419
	208093	Gasket-sight glass (not illustrated)	312 420
11	800840	Ignition lead	278 126
12	202211	Control board (PCB)	379 239
13	208560	Condensate sensor	409 902
14	800659	Fan	278 263
15	202625	Electrode	278 096

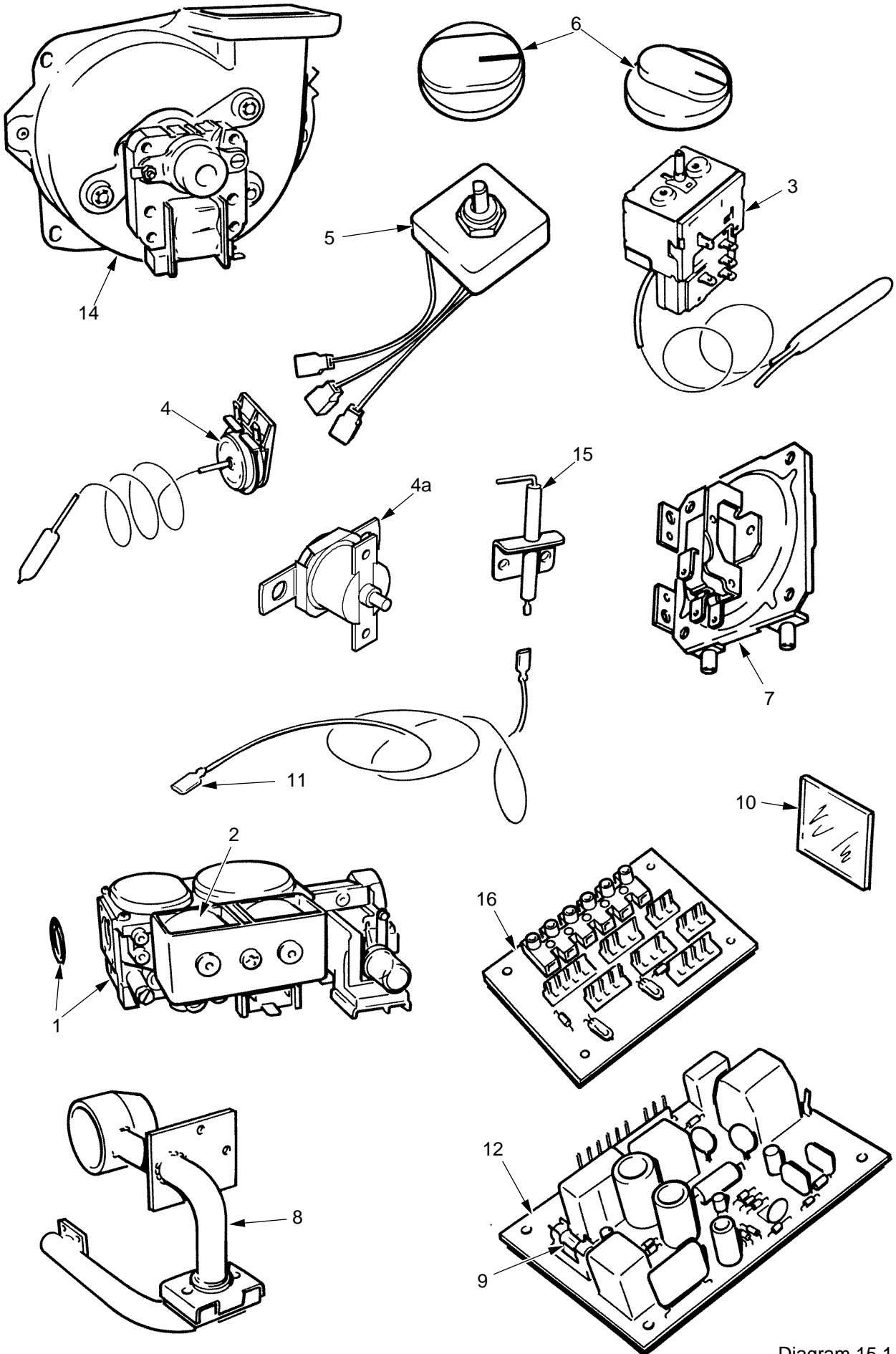

Diagram 15.1

Information for the Installer and Service Engineer

Under Section 6 of the Health and Safety at Work Act 1974, we are required to provide information on substances hazardous to health.

The adhesives and sealants used in this appliance are cured and give no known hazard in this state.

INSULATION PADS/CERAMIC FIBRE, GLASS YARN and MINERAL WOOL

These can cause irritation to skin, eyes and the respiratory tract.

If you have a history of skin complaint you may be susceptible to irritation. High dust levels are usual only if the material is broken.

Normal handling should not cause discomfort, but follow normal good hygiene and wash you hands before eating, drinking or going to the lavatory.

If you do suffer irritation to the eyes or severe irritation to the skin seek medical attention.

THERMOSTATS

These contain very small amount of xylene in the sealed phial and capillary. If broken, under normal circumstances the fluid does not cause a problem, but in cases of skin contact, wash with cold water.

If swallowed drink plenty of water and seek medical attention.

CUT OFF DEVICES

Cut off devices with copper phial/bulb only.

Bulb contains activated charcoal and very small amounts of chlorodifluoromethane in the sealed phial and capillary. If broken under normal circumstances the fluid does not cause a problem. If there is irritation to the eyes or skin then seek medical attention.

FLUE SEALANT

This contain cyclohexylaminosilane.

It may cause irritation of skin of sensitive persons. Was contact area with soap and water, if irritation occurs, seek medical advice.

Will cause irritation on contact with eyes. If so, wash eye with large amounts of fresh water for at least 15 minutes.

If irritation persists, seek medical advice.

If swallowed drink plenty of milk and seek medical attention.

Because of our constant endeavour for improvement details may vary slightly from those in the instructions.