



Glow-worm

Installation and Servicing Instructions

To be left adjacent to the gas meter

FUELSAVER 60B Mk II

G.C. Number 41 313 10

FUELSAVER 75B Mk II

G.C. Number 41 313 11

Balanced Flue Boilers

With Honeywell Control

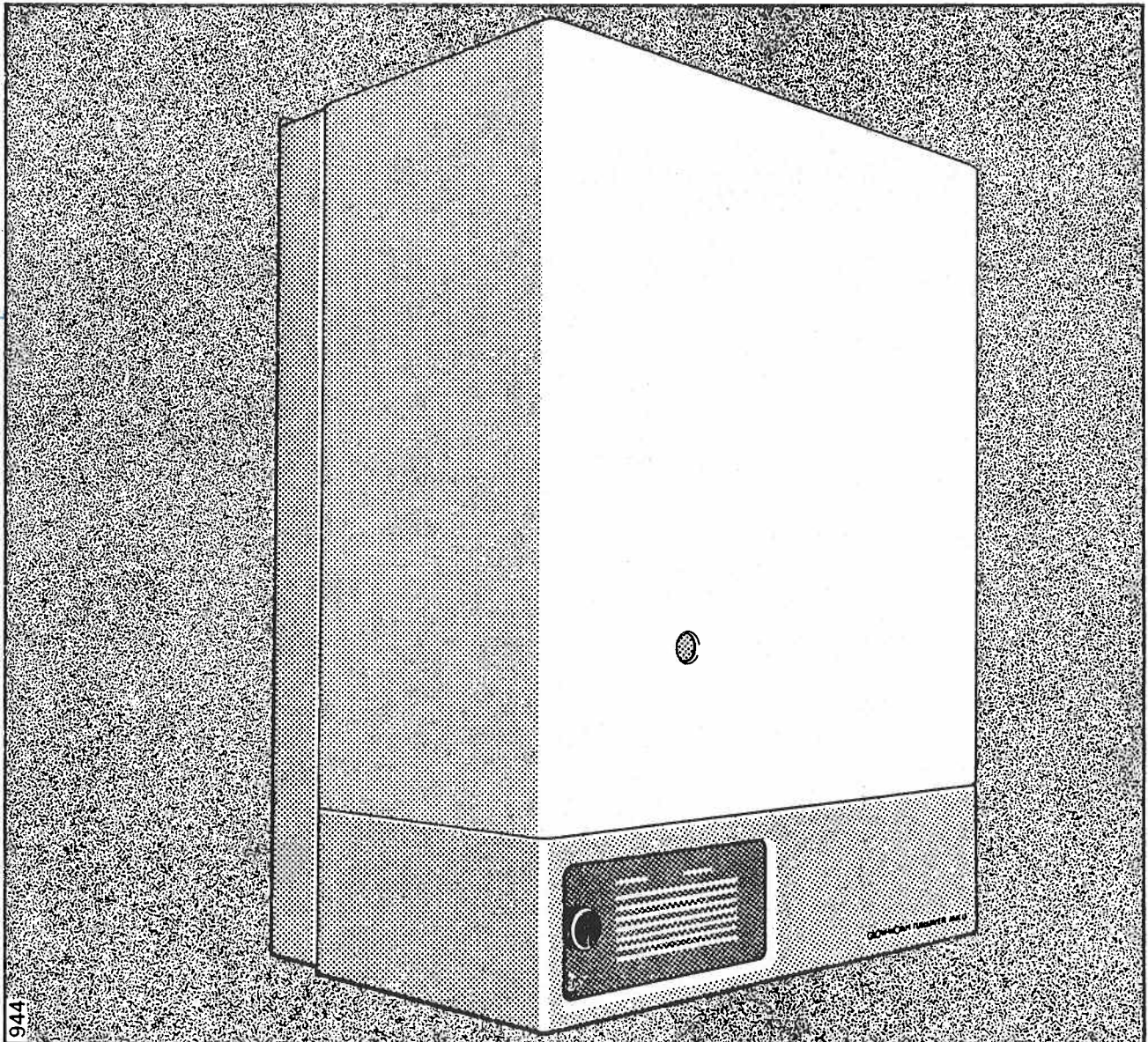

1 GENERAL

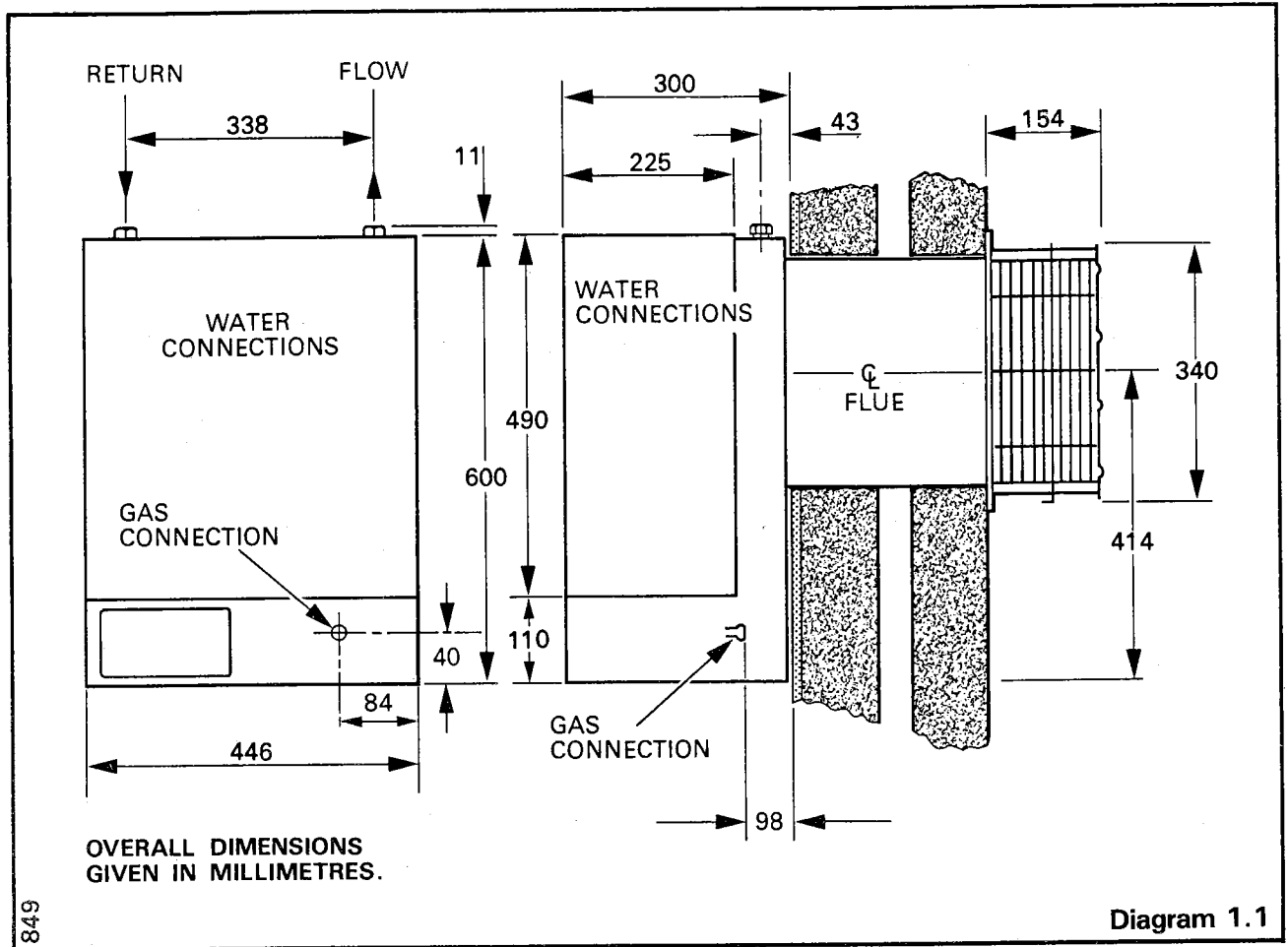

IMPORTANT NOTICE: The Fuelsaver Mk II boilers are for use on natural gas only and MUST NOT be used on any other gas.

Electrical supply: 240V, 50Hz, ~ fused 3A
 Gas connector: Rc $\frac{1}{2}$ ($\frac{1}{2}$ in BSPT)
 Water connection: 28mm Copper

Model	75B Mk II	60B Mk II
Weight Complete:	33.2 kg (73.1 lb)	32 kg (71 lb)
Water Content:	0.75 litre (0.17 gal)	0.71 litre (0.16 gal)
Injector, Bray:	marked 4.1	marked 3.8-301700

Burner: Bray AB 24023 or Furigas 170/500/004

ALL DIMENSIONS GIVEN IN MILLIMETRES, see diagram 1.1 and 1.2.

When installing or servicing these appliances, care should be taken when handling the edges of sheet metal parts, to avoid any possibility of injury.

1.1 RANGE RATING

THIS BOILER MAY BE RANGE RATED TO SUIT INDIVIDUAL SYSTEMS. THE FOLLOWING TABLE GIVES THE MAXIMUM AND MINIMUM OUTPUTS.

The boiler input is factory pre-set at maximum and should be adjusted to suit the system requirements.

Glow-worm FUELSAVER 60B Mk II			
RANGE RATING	min	medium	max
NOMINAL HEAT INPUT	kW	18.47	22.00
	Btu/h	63,000	75,000
NOMINAL HEAT OUTPUT	kW	14.66	17.59
	Btu/h	50,000	60,000
BURNER SETTING PRESSURE	m bar	9.3	13.4
	in.w.g.	3.7	5.4

Glow-worm FUELSAVER 75B Mk II			
RANGE RATING	min	medium	max
NOMINAL HEAT INPUT	kW	22.13	27.50
	Btu/h	75,500	93,800
NOMINAL HEAT OUTPUT	kW	17.60	22.00
	Btu/h	60,000	75,000
BURNER SETTING PRESSURE	m bar	10.5	16.1
	in.w.g.	4.2	6.4

PLEASE REMEMBER:

YOU MUST ALWAYS USE THE PUMP.
 YOU MUST ALWAYS INCORPORATE PUMPED
 PRIMARIES TO A H.W. CYLINDER.
 THE PUMP CAPACITY MUST BE ADEQUATE FOR
 THE SYSTEM.
 INCORRECT WIRING CAN BE DANGEROUS.
 STATIC HEAD IS IMPORTANT.
 BALANCE THE SYSTEM.
 VENT THE SYSTEM BEFORE FIRING THE BOILER.
 ALWAYS ALLOW ACCESS FOR SERVICING THE
 BOILER AND ANY CONTROLS.
 THE PUMP MUST BE WIRED TO THE BOILER
 CONTROL BOX.
 IN 'HARD' OR 'AGGRESSIVE' WATER AREAS IT
 IS RECOMMENDED THAT AN INHIBITOR IS USED,
 SUCH AS 'FERNOX CP3'.

1.2 PROCEDURE

It is essential that the boiler is installed strictly in accordance with the instructions in this booklet and the attention of the installer is drawn in particular to the following points.

1.3 STATUTORY REQUIREMENTS

THE INSTALLATION OF THIS BOILER MUST BE CARRIED OUT BY A COMPETENT PERSON AND MUST BE IN ACCORDANCE WITH THE RELEVANT REQUIREMENTS OF THE CURRENT ISSUE OF THE GAS SAFETY (Installation & Use) REGULATIONS, RELEVANT BUILDING REGULATIONS, I.E.E. WIRING REGULATIONS, BYELAWS OF THE LOCAL WATER UNDERTAKING and THE BUILDING STANDARDS (Scotland) REGULATIONS.

DETAILED RECOMMENDATIONS ARE CONTAINED IN THE FOLLOWING BRITISH STANDARD CODES OF PRACTICE, CP331 PART 3, BS5376 PART 2, BS5440 PART 1, BS5440 PART 2, BS5449 PART 1 AND BS5546.

1.4 GAS SUPPLY

Installation pipes should be fitted in accordance with CP331 Part 3. Pipework from the meter to the boiler must be of adequate size. Pipes of a smaller size than the boiler inlet gas connection should not be used. The complete installation must be tested for soundness as described in the above code.

1.5 ELECTRICAL

All electrical wiring must be carried out by a competent electrician. All external components shall be of the approved type and shall be wired in accordance with the I.E.E. Wiring Regulations and any local regulations which apply. The boiler must be earthed and connections to the mains supply should preferably be through a standard 13 amp shuttered socket outlet and 3 amp fused 3 pin plug. Alternatively, a 3 amp fused double pole isolating switch may be used, having a minimum contact separation of 3mm, serving only the boiler. Heat resistant flexible cable of at least 0.75mm² (24/0.20mm), to BS6500 table 9 must be used for all wiring to the control box.

1.6 B.S.I. CERTIFICATION

1.6.1 This boiler is certified by B.S.I. for safety and performance. It is therefore, important that no alteration is made to the boiler unless recommended in writing by T.I. Glow-worm Ltd.

1.6.2 Any alteration not approved by T.I. Glow-worm Ltd. could invalidate the B.S.I. certification, appliance warranty and could also infringe the Gas Safety (Installation & Use) Regulations.

1.7 BOILER LOCATION

1.7.1 The boiler position should be such that the minimum clearances are provided as shown in diagram 1.2.

1.7.2 The boiler may be installed in any room, although particular attention is drawn to the requirements of the I.E.E. Wiring Regulations, with respect to the installation of the boiler in a room containing a bath or shower. Any electrical switch or boiler control utilising mains electricity should be so situated that it cannot be touched by a person using the bath or shower. The electrical provisions of the Building Standards (Scotland) Regulations are applicable to such installations in Scotland.

1.7.3 Where the installation of the boiler will be in an unusual location, special procedures may be necessary and BS5376 Part 2 gives detailed guidance on this aspect.

1.7.4 A compartment used to enclose the boiler must be designed and constructed specifically for this purpose. An existing cupboard or compartment may be used providing that it is modified for the purpose. Details of essential features of cupboard compartment design, including airing cupboard installations are given in BS5376 Part 2.

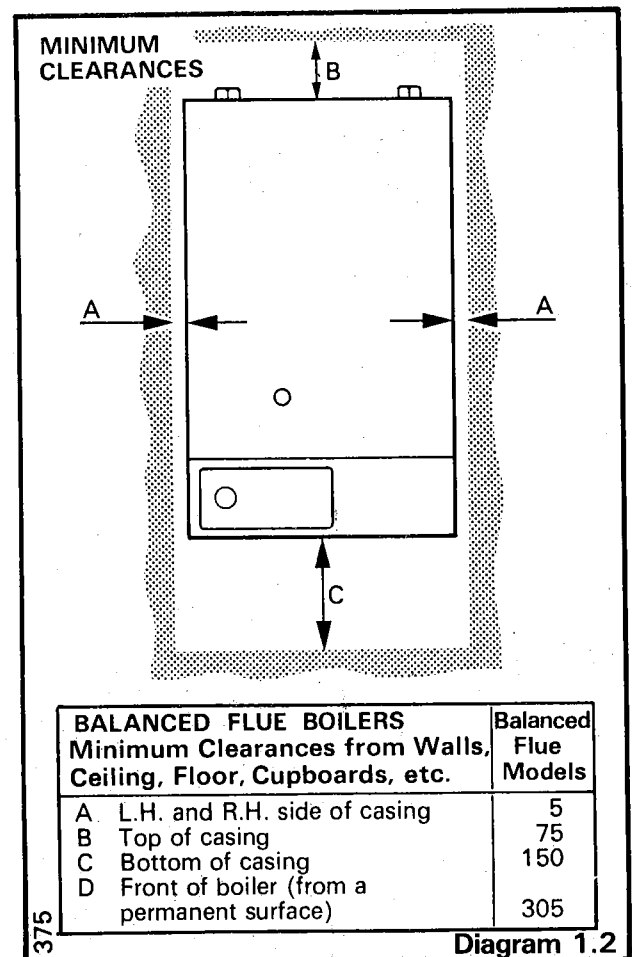

2 FLUE AND VENTILATION

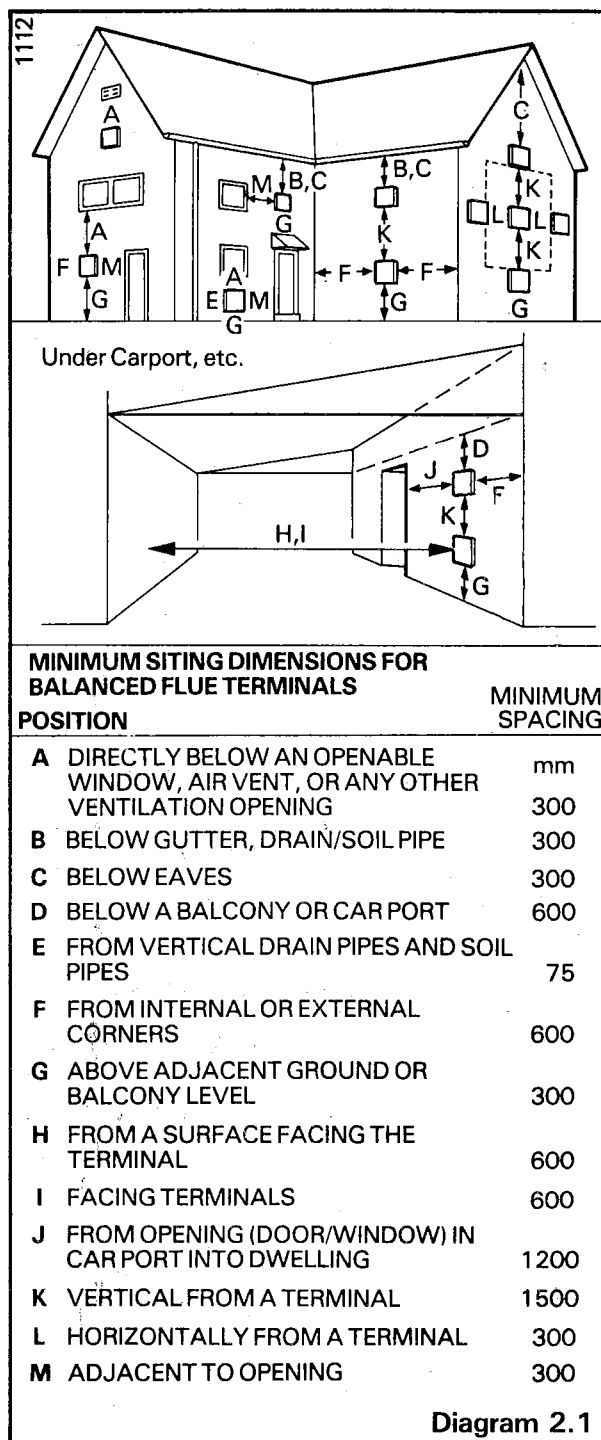

AIR VENT AREA TABLE FOR COMPARTMENT INSTALLATIONS				
POSITION OF AIR VENTS	AIR VENT AREAS			
	AIR FROM ROOM OR INTERNAL SPACE		AIR DIRECT FROM OUTSIDE	
	60B	75B	60B	75B
HIGH VENT	200 ^{cm²}	250 ^{cm²}	100 ^{cm²}	125 ^{cm²}
LOW VENT	200 ^{cm²}	250 ^{cm²}	100 ^{cm²}	125 ^{cm²}

853

2.1 BALANCED FLUE UNIT

Detailed recommendations for flueing are given in BS 5440:1. The following notes are intended to give general guidance.

- 2.1.1 The boiler must be installed so that the terminal is exposed to the external air. It is important that the position of the terminal allows the free passage of air across it at all times.
- 2.1.2 The minimum acceptable spacings from the terminal to obstructions, ventilation openings and other terminals are specified in diagram 2.1.
- 2.1.3 If the terminal is fitted within 850mm of a plastic or painted gutter or 450mm of painted eaves, an aluminium shield of at least 750mm long should be fitted in the underside of the gutter or painted surface.
- 2.1.4 The air inlet/products outlet duct and the terminal of the boiler must not be closer than 50mm to combustible material. Detailed recommendations on protection of combustible material are given in BS 5440:1, sub-clause 20.1.

2.2 TIMBER FRAMED HOUSING

If the appliance is to be installed in a timber framed building it should be fitted in accordance with the British Gas Publication - "Guide for Gas Installation in Timber Framed Housing", reference DM2. If in doubt seek advice from the local region of British Gas or T.I. Glow-worm Ltd.

2.3 PROTECTING THE TERMINAL

- 2.3.1 Where the terminal is less than 2 meters above the level of any ground, balcony, flat roof etc., to which any person has access, and which adjoins the wall in which the terminal is situated, the terminal must be protected by a guard of durable material.
- 2.3.2 Guards are available from Tower Flue Components Ltd., telephone Tonbridge 351555, quoting reference 'F' Black, or from Quinnell, Barrett and Quinnell Ltd., 884 Old Kent Road, London S.E.15, quoting reference type 'M4'.

2.4 ROOM VENTILATION

Where the boiler is fitted in a room, or internal space, the boiler does not require the room or internal space, containing it to have a permanent air vent.

2.5 CUPBOARD/COMPARTMENT VENTILATION

- 2.5.1 Where the boiler is fitted in a cupboard or compartment, the ventilation area must be in accordance with AIR VENT TABLE.
- 2.5.2 Both the high level and low level air vents must communicate with the same room, or internal space, or must both be on the same wall to outside air.

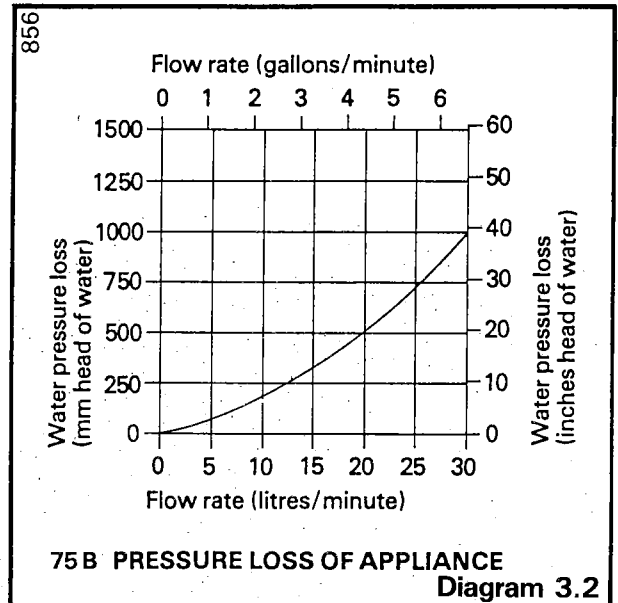
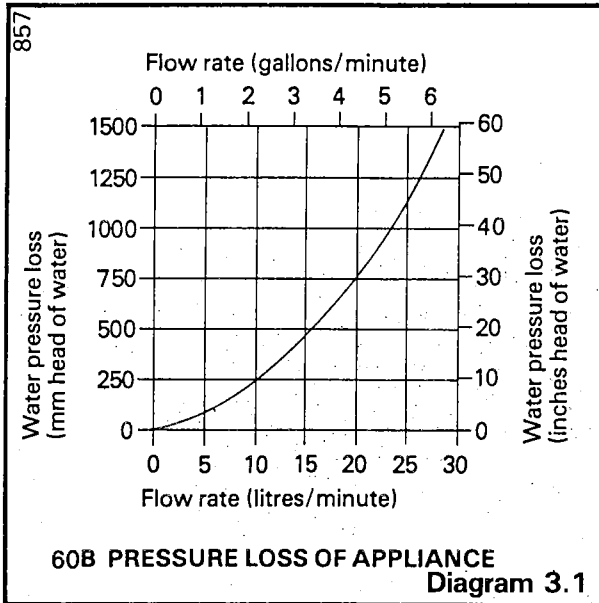

3.1 PUMP

3.1.1 The pump should be fitted in the flow pipe from the boiler and it is recommended that a pump producing at least 3 metres head is used, to give a temperature rise of approximately 11°C, (20°F). The pump should then give a flow rate through the boiler as follows:

Fuelsaver 60B MkII 23 litres/min (5.1 gal/min)

Fuelsaver 75B MkII 28.7 litres/min (6.3 gal/min)

3.1.2 For details of pressure loss of boiler see appropriate graph, diagram 3.1 for 60B model or 3.2 for 75B model. Examples of suitable approved pumps are SMC Commodore 2-130-60, Grundfos UPS 15-50 and Euramo MXL 130/180 High resistance microbore systems may require a higher duty pump.

3.2 BY-PASS

A by-pass must be fitted, see diagram 3.3. The flow through the boiler while the burner is alight must not be allowed to fall below the following minimum flow rates:

Fuelsaver 60B MkII 18 litres/min (3.9 gal/min)

Fuelsaver 75B MkII 22.5 litres/min (4.9 gal/min)

3.3 CYLINDER

The hot water cylinder must be a double feed (fully indirect) pattern. Single feed (self-priming) cylinders are not recommended, and must not be used on sealed systems.

3.4 SAFETY VALVE

In an open (vented) water system the provision of a safety valve is necessary if local regulations stipulate that one must be used. A safety valve must be fitted in a sealed water system. For further details on the fitting of a safety valve refer to section 4.2.

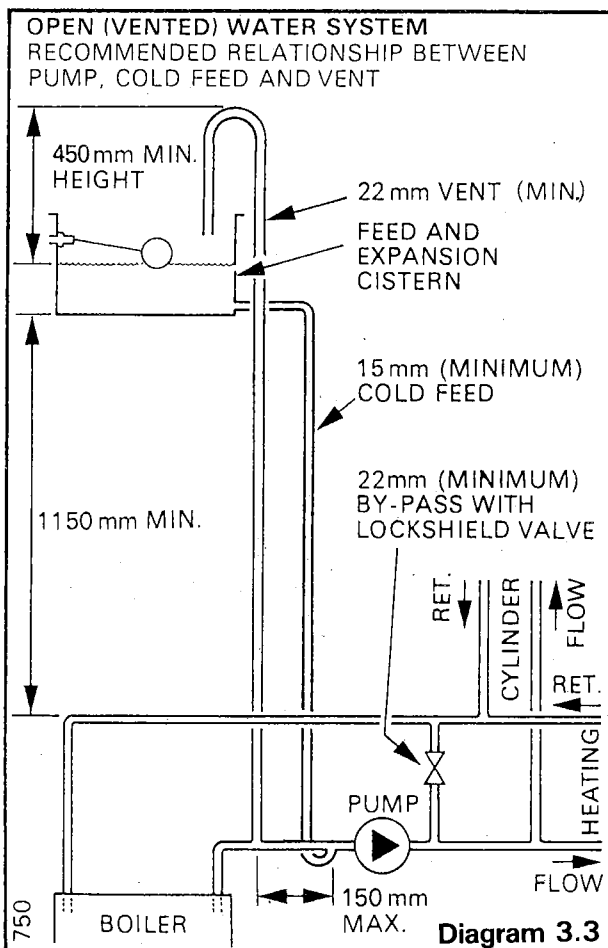

3.5 OPEN (VENTED) WATER SYSTEMS

3.5.1 A 22mm diameter open vent pipe must be fitted in the flow line from the boiler and terminated above the cold feed and expansion cistern, which should be not less than 22 litre (5 gallon) capacity.

3.5.2 The vent must have a continuous rise to discharge over the cistern. Horizontal runs should be avoided. It is essential that no valve is fitted to the open vent.

3.5.3 The cistern must not be situated more than 27.5 meters (90 feet) above the boiler.

3.5.4 A 15mm diameter minimum cold feed must be fitted in the system.

3.5.5 For an open (vented) system it is important that the relative positions of the pump, cold feed and open vent should be as in diagram 3.3.

3.6 DRAINAGE

Drain-off cocks which allow the drainage of the entire system, including the boiler and hot water storage vessel, must be provided for subsequent servicing. A drain point is provided, for heat exchanger drainage, on the body.

3.7 WATER CONNECTIONS

The boiler is supplied with nuts and olives to accept 28mm diameter copper pipe to BS 2871. The right-hand connection is the flow from the boiler, the return is the left-hand.

3.8 INHIBITOR

3.8.1 If an inhibitor is to be used in the system, it is recommended by Industrial (Anti-corrosion) Services Ltd. that 'Ferno CP3' is used, in accordance with their instructions.

3.8.2 Where installing a Fuelsaver boiler into an existing system, special care should be taken to drain the entire system including radiators, then thoroughly flush out before installing the boiler and adding the inhibitor.

4.1 GENERAL

The installation should comply with the appropriate requirements of BS 5376 Part 2 and BS 5449 Part 1, see diagram 4.1 for layout.

4.2 SAFETY VALVE

4.2.1 A spring-loaded safety valve complying with the relevant requirements of BS 759 shall be fitted and shall incorporate the following features:

- (a) A pre-set, non-adjustable lift pressure not exceeding 3 bar (45 lbf/in²).
- (b) A seating or valve face of suitable material.
- (c) A manual test device.
- (d) Provision for connection to a discharge pipe.

4.2.2 The safety valve shall be fitted in the flow pipe, as near as is practicable to the boiler with no intervening valve or restriction. It should be fitted by a horizontal or vertically upward connection, accessible for testing.

4.2.3 The safety valve shall be so positioned or any discharge pipe so arranged that discharge of water or steam from the valve cannot create a hazard to occupants of the premises or cause damage to electrical components and wiring.

4.3 EXPANSION VESSEL

4.3.1 A diaphragm type expansion vessel shall be connected at a point close to the inlet side of the circulating pump in a manner laid down in the vessel maker's instruction, see illustration of recommended system layout diagram 4.1.

4.3.2 The expansion vessel must be chosen to suit the volume of water in the system, refer to BS 5449, Part 1 clause 25 for further details. The charge pressure shall not be less than the static head at the point of connection. (i.e. height of the top point of the system above the expansion vessel).

4.3.3 The diaphragm expansion vessel should have an acceptance volume sufficient to accommodate the volume change of the system water when heated from 10°C to 110°C. The practical acceptance volume is that which the vessel will accommodate when the gauge pressure developed rises to 0.35 bar (5 lbf/in²) less than the safety valve setting. For most systems the ratio will be between 8:1 and 12:1 (see BS 5449 Part 1 for specific information). The volume of water in the appliance is given in section 1, General.

4.4 PRESSURE GAUGE

A pressure gauge with set pointer and covering at least the range 0 to 4 bar (0 to 60 lbf/in²) shall be permanently fitted to the system in a position visible to the person carrying out the filling operation.

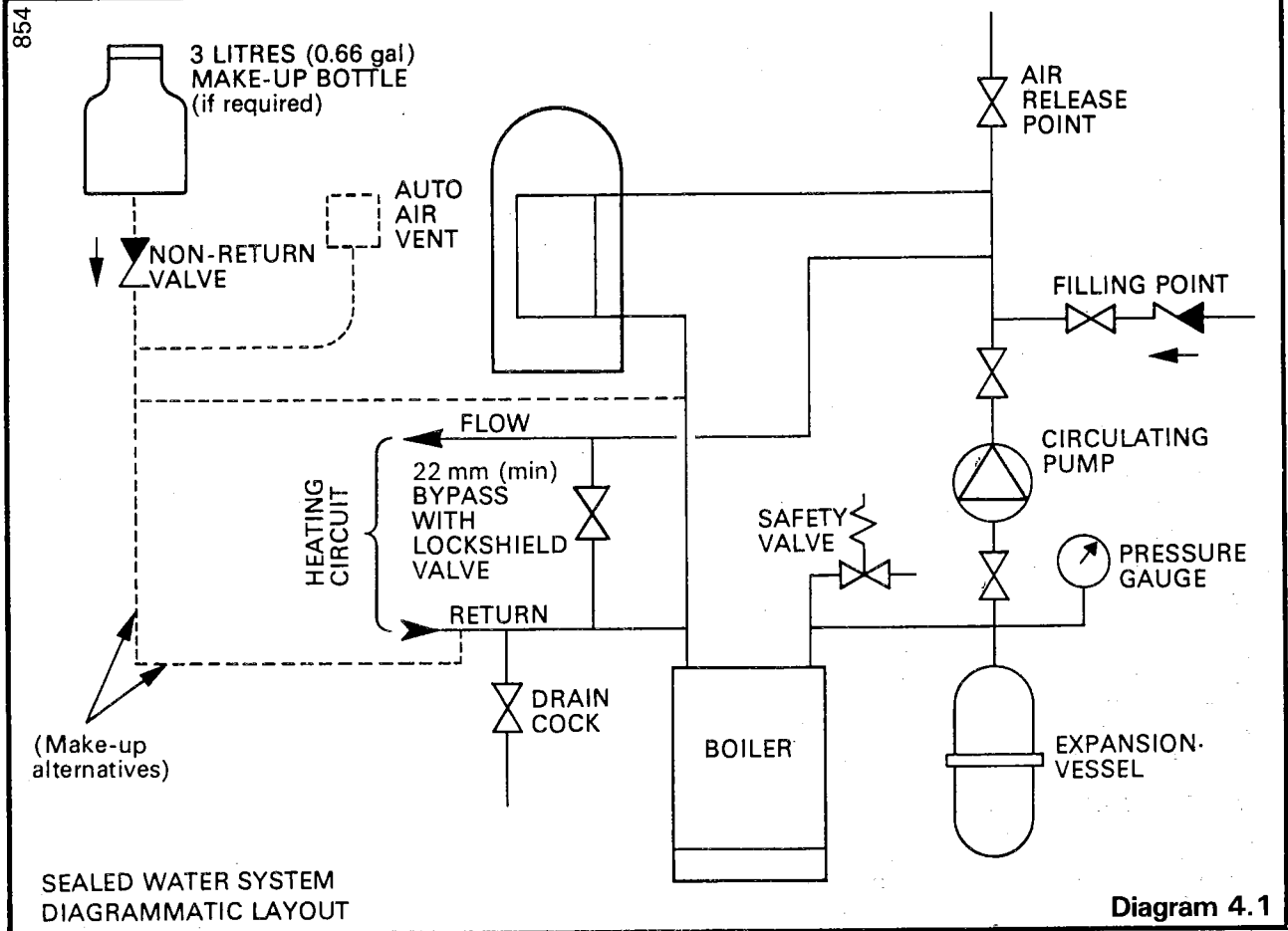

4.5 CYLINDER

The hot water cylinder shall be either of the indirect coil type or a direct cylinder fitted with an immersion calorifier which is suitable for operating at gauge pressure of 0.35 bar (5 lb/in²) in excess of the safety valve setting. Single feed indirect cylinders are not suitable.

4.6 MAKE-UP

Provision shall be made for replacing water lost from the system either from a make-up vessel mounted in a position higher than the top point of the system and connected through a non-return valve to the system on the return side of either the hot water cylinder or heating circuit. Where access to a make-up vessel would be difficult provision for make-up can be made by pre-pressurisation of the system, see also 4.8 Filling.

4.7 MAINS CONNECTIONS

There must be no connection to the mains water supply or to a water storage cistern supplying domestic water even through a non-return valve without the approval of the local Water Authority undertaking.

4.8 FILLING

The system is to be fitted with a filling point at low level. Methods of filling and making up sealed systems are described in BS 5376 Part 2 Appendix A. Two methods of filling are shown in diagram 4.2.

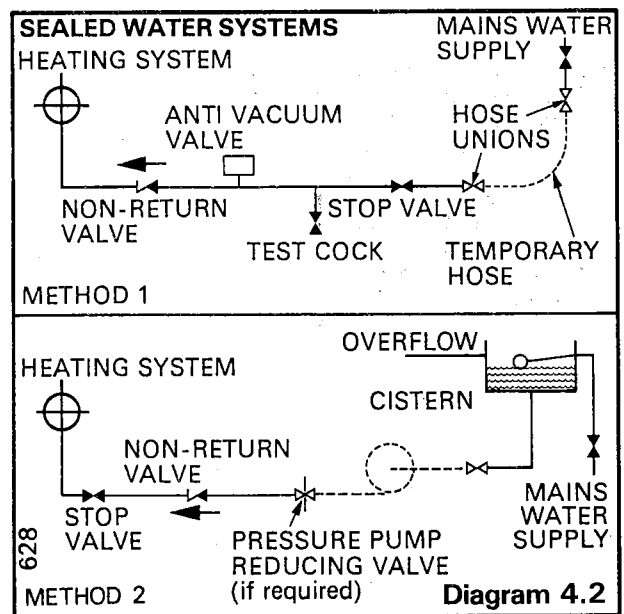

5 FLUE TERMINAL AND AIR DUCT

5.1 FLUE LENGTHS

5.1.1 Check that the balanced flue set supplied is suitable for the wall thickness through which it has to pass.

5.1.2 The standard flue set supplied is suitable for wall thicknesses 238mm to 330mm. For alternative wall thicknesses, a short flue kit No.421099 for 76mm to 238mm and a long flue kit 421061 for 324mm to 580mm are available to order.

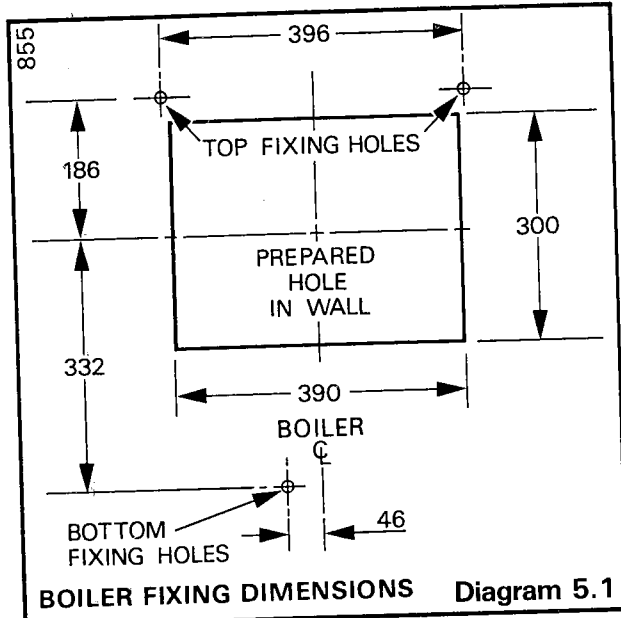

5.2 POSITIONING

5.2.1 Place the template provided on the wall in the required boiler position and mark location of balanced flue hole, see diagram 5.1.

5.2.2 Cut the hole in the wall which will be 300mm high by 390mm wide to accept the air duct.

5.2.3 Make good any plasterwork necessary at this stage. When dry, select the liner with the turned flange at one end 'C' see diagram 5.1. Push into the cavity until the flange is flush to the wall. Fit the second half of the liner 'B' from inside so that it is flush with the outside brickwork. Mark the two liner positions and remove from cavity. Align the marks on the liners and tape the two together with the tape provided.

5.2.4 The extension 'B' is not required when the wall thickness is equal to the length of duct.

5.2.5 Re-position the template on the wall in line with wall opening or refer to diagram 5.1.

5.2.6 Mark positions for the three fixing screws.

5.2.7 Drill and plug the three fixing hole, suitable for No.10 x 50mm long wood screws and wall plugs.

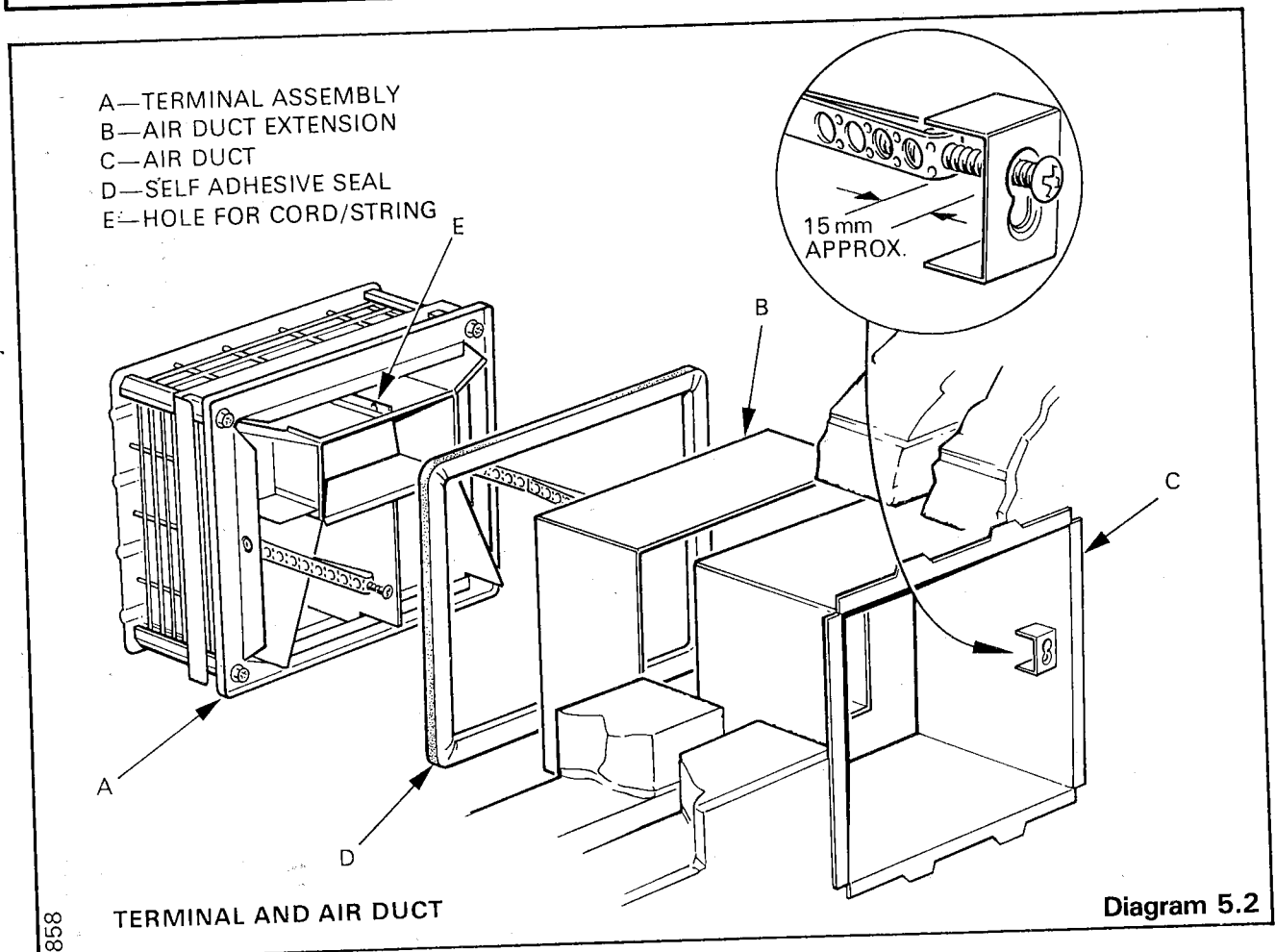

5.3 EXTERNAL ACCESS PROCEDURE

- 5.3.1 Fit the air duct assembly, already prepared, into the hole in the wall, from inside the room.
- 5.3.2 Attach the adhesive seal 'D' to the terminal wall plate, see diagram 5.2.
- 5.3.3 Place the terminal against the outside wall with the inner flange of the wall plate located inside the air duct assembly. Support the terminal in any suitable way, alternatively:
- 5.3.4 Attach a length of strong string, cord etc., to the terminal through the small hole 'E' provided in the top centre baffle, see diagram 5.2. Attach a suitable weight to the free end of the string. Pass the weight and string through the hole in the wall to support the terminal. NOTE: The terminal 'TOP' is indicated.
- 5.3.5 Working from inside the room, bend the two perforated straps around the hex. nuts provided at approx. 15mm from the brackets on the air duct assembly, see diagram 5.2.
- 5.3.6 Secure the two straps with the screws and nuts, the screw head passing first through the large part of the keyhole in the bracket, then sliding into the smaller recessed portion.
- 5.3.7 Tighten the screws to tension the straps securing the terminal in position, but do not overtighten. Cut off any surplus on the straps and remove cord or string if used.

5.4 INTERNAL ACCESS PROCEDURE

NOTE: It is possible to install the terminal from inside the building, up to a maximum wall thickness of 330mm. Should this be required, proceed according to the following paragraphs:

- 5.4.1 Fit the air duct assembly already prepared into the hole in the wall.
- 5.4.2 Attach the adhesive seal 'D' to the terminal wall plate 'A', see diagram 5.2.
- 5.4.3 Attach a length of strong string, cord etc., to the terminal through the small hole 'E' provided in the top centre baffle, see diagram 5.2. Attach a suitable weight to the free end of the string.
- 5.4.4 Pass the terminal through the duct assembly, using the straps to manoeuvre the terminal into position. NOTE: The terminal 'TOP' is indicated and the inside flange of the wall plate is located inside the air duct assembly. The weight will now support the terminal in position.
- 5.4.5 Bend the two perforated straps around the hex. nuts provided, see diagram 5.2.
- 5.4.6 Secure the two straps with the screws and nuts, the screw head passing first through the large part of the keyhole in the bracket, then sliding into the smaller recessed portion.
- 5.4.7 Tighten the screws to tension the straps securing the terminal in position, but do not overtighten. Cut off any surplus on the straps and remove cord or string.

6.1 BOILER PREPARATION & FIXING

- 6.1.1 Remove the controls cover by pulling forward until it is clear of the boiler, thus exposing the controls.
- 6.1.2 Remove outer case by slackening the screw at the bottom and unhooking at the top, see diagram 6.1.
- 6.1.3 Remove the inner case by slackening the screws at top and bottom.
- 6.1.4 Remove the flue hood by unscrewing the wing nuts holding the securing angle, see diagram 6.2 and remove the angle. Lift off the flue hood.
- 6.1.5 Carefully lay the boiler face downward taking care not to damage the controls facia.

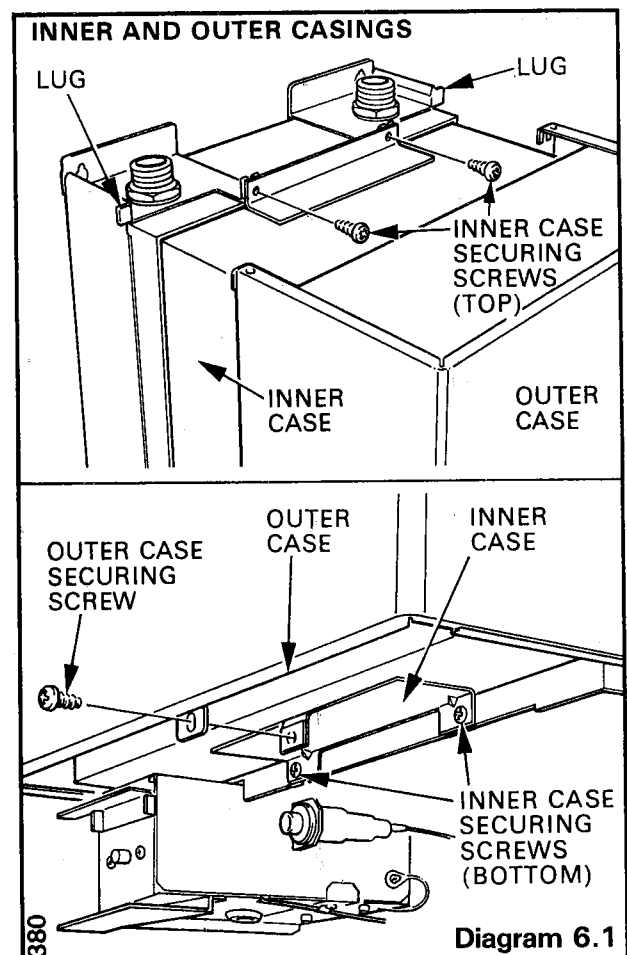

6 INSTALLATION

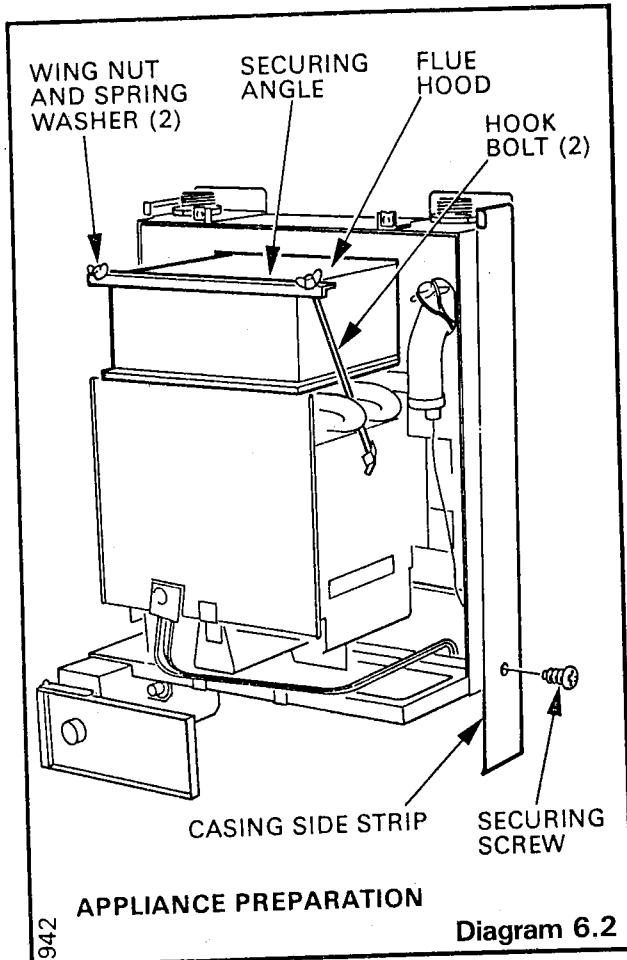

6.1.6 Remove the backing strip from the case seal 'J' provided and fit around the spigot on the back of the boiler with the adhesive edge to the back of the case, see diagram 6.3.

6.1.7 Remove the two side strips from the bottom package fitment and hook over the top edge of the side panel, see diagram 6.2. Secure each side strip with one screw at the bottom.

6.2 APPLIANCE FIXING

6.2.1 Fit the top two fixing screws, allowing them to protrude from the wall surface to accept the keyhole slots on the appliance.

6.2.2 Hook the appliance on to the two screws. Fit the bottom screw and tighten all three.

6.3 STANDARD & SHORT FLUE ONLY

6.3.1 Push the flue duct 'G' into the terminal with the unflanged end entering the terminal. Ensure that the lower flange of the duct fits behind the combustion chamber rear panel. For walls less than 150mm thick, cut the surplus length from the unflanged end of flue duct 'G', to suit the wall thickness, see diagram 6.3.

6.3.2 Fit the two screws through the flue duct flange and sealing plates but do not tighten fully.

6.3.3 Replace the flue hood 'H', inserting the rear into the flue duct. Push down on the rear of the hood and tighten the duct screws. Refit the securing angle, hook bolts, wing nuts and spring washers firmly, but do not overtighten.

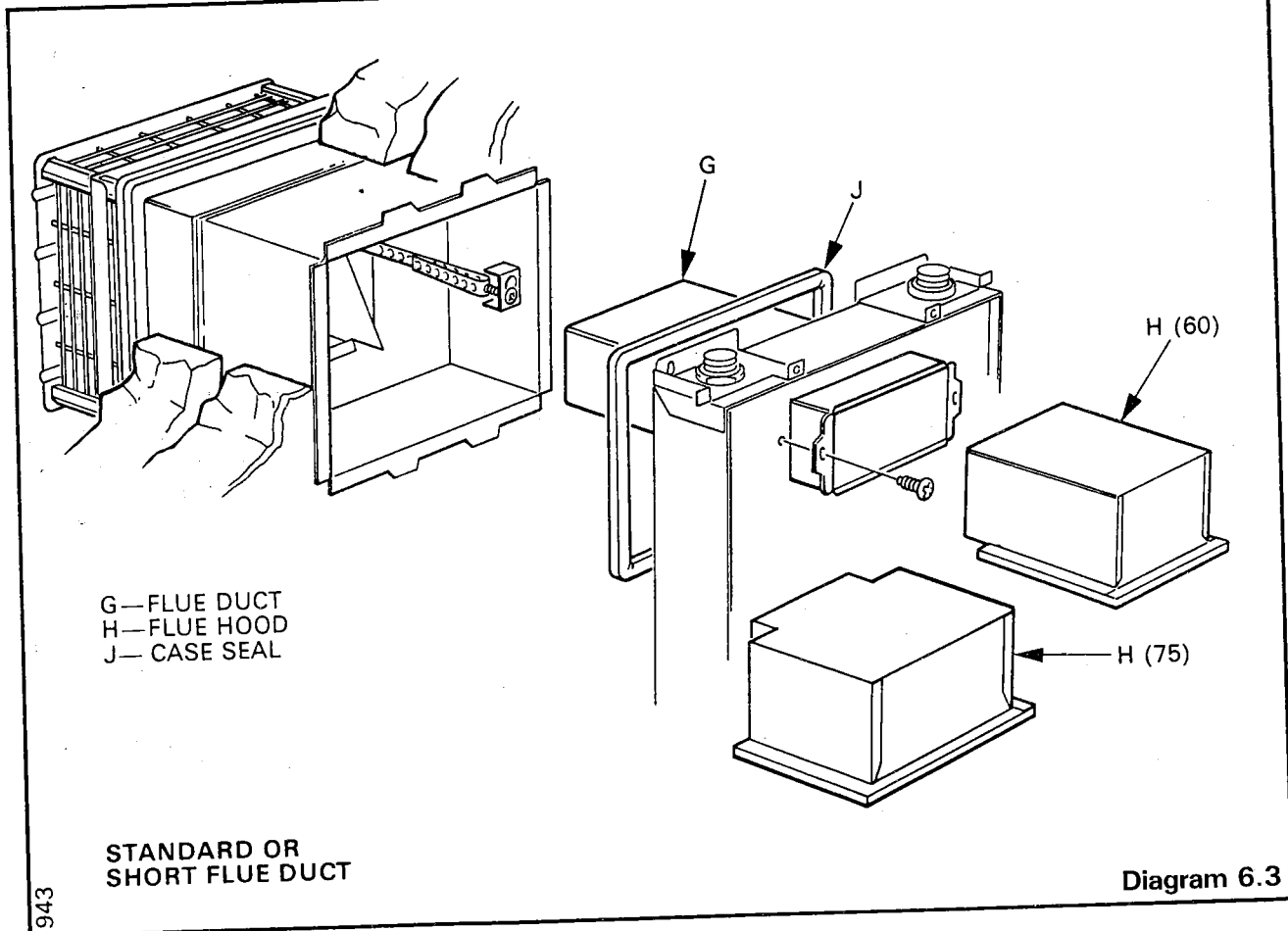

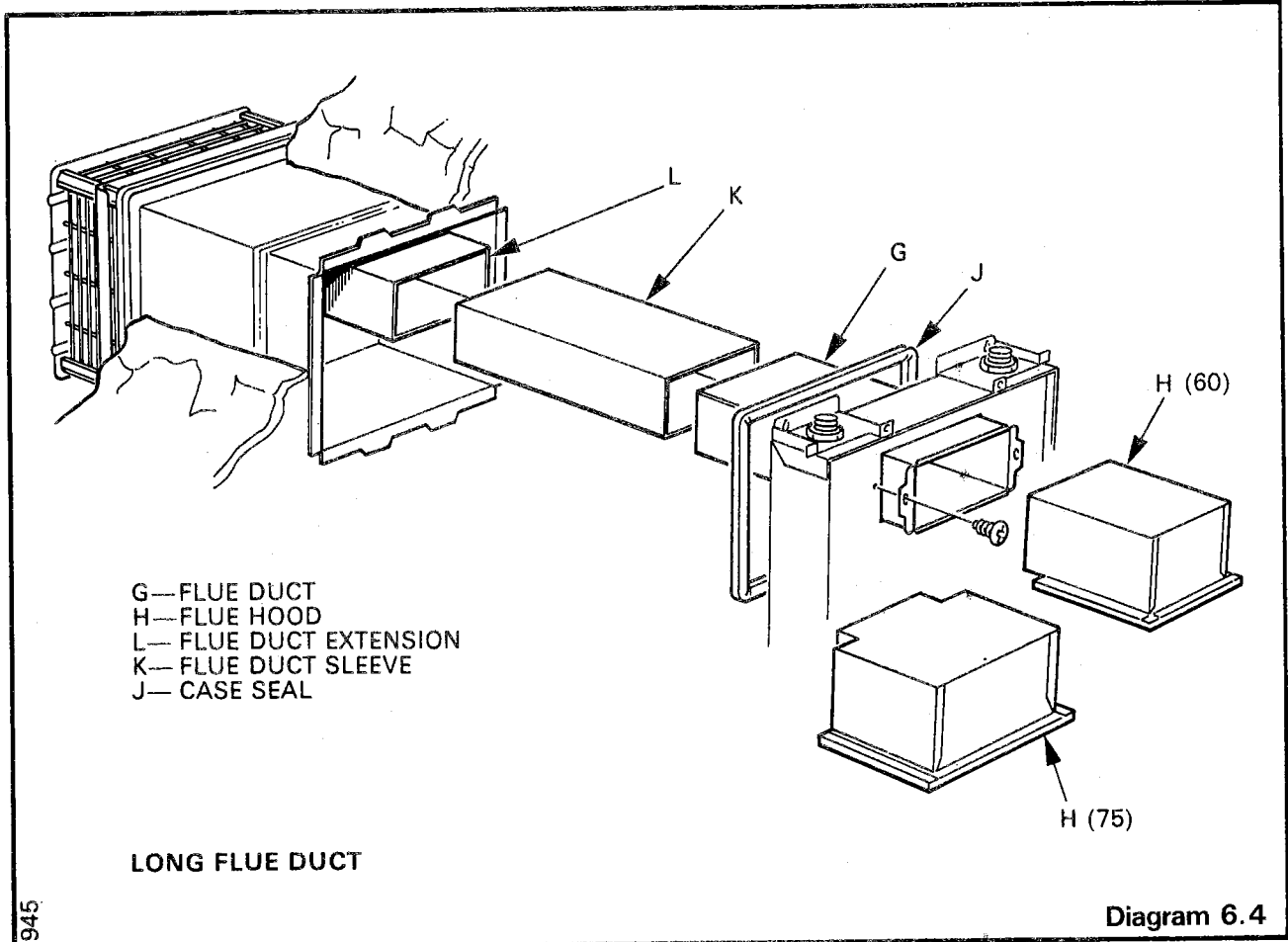

945

6.3.4 Re-fit the inner case and secure with the screws previously removed.

6.4 LONG FLUE SET ONLY

6.4.1 For long flue sets the flue duct 'G', extension 'L' and sleeve 'K' need to be assembled together to suit the wall thickness required. This assembly is 75mm longer than the air duct assembly already prepared. A minimum overlap of 40mm is required at each joint. Use the tape provided to make a permanent assembly of the three flue elements, see diagram 6.4

6.4.2 Push the flue duct assembly into the terminal, with the unflanged end entering the terminal. Ensure that the lower flange of the duct fits behind the combustion chamber rear panel.

6.4.3 Fit the two screws through flue duct flange and sealing plates, but do not tighten fully.

6.4.4 Replace the flue hood 'H', inserting the rear into the flue duct. Push down on the rear of the hood, and tighten the sealing plate screws. Re-fit the securing angle, tie-rods and wing nuts firmly, but do not overtighten.

6.4.5 Re-fit the inner case, and secure it with the screws previously removed.

7.1 GAS

7.1.1 The gas inlet to the appliance is Rc $\frac{1}{2}$ ($\frac{1}{2}$ in BSPT) and is situated at the base of the appliance on the gas cock.

7.1.2 The gas meter must be capable of passing, in addition to all other demands, as follows:

Natural Gas Requirements

Fuelsaver 60B Mk II 2.1 m³/h (75 ft³/h)

Fuelsaver 75B Mk II 2.6 m³/h (94 ft³/h)

7.1.3 The meter governor must ensure a constant outlet pressure of 20 mbar, (8in w.g.). The gas installation should be in accordance with CP331 Part 3. The whole of the gas installation, including the meter should be inspected and tested for soundness and purged in accordance with the recommendations of CP331 Part 3.

7.2 WATER

7.2.1 The boiler is supplied with nuts and olives to accept 28mm diameter copper tubing to BS 2871.

7.2.2 The right hand connection is the flow from the boiler the return is the left hand.

8 ELECTRICAL WIRING

8.1 SUPPLY CABLE CONNECTION

8.1.1 Remove the control box by removing the two screws at the front above the fascia, and lower the front of the box until it is clear of its cover. Push box towards the rear of boiler to disengage its hinging at the rear, and lower the box, see diagram 8.1. The box will still be attached to the boiler via the plastic retaining strap. If the box is to be removed entirely, pull the strap off the plastic fastener. Care should now be taken not to damage thermostat and overheat cut-off capillaries or electrical cables. Refit the retaining strap with plastic fastener.

8.1.2 Thread the mains cable in through the centre bottom grommet in the rear of the controls cover, through the cable clamp and connect to the terminal strip, see diagram 8.1 and 8.2. When making connections, ensure that the earth conductor is made longer than the line and neutral conductors, so that if the cable is strained the earth conductor will be the last to be disconnected.

NOTE: THIS BOILER MUST BE EARTHED AND HAVE A PERMANENT MAINS SUPPLY.

8.1.3 The electrical isolator must isolate both the boiler and any system controls.

8.2 PUMP CABLE CONNECTION

The pump must be connected to the boiler control box as shown in the wiring diagram passing the cable through the hole in the rear of the control box.

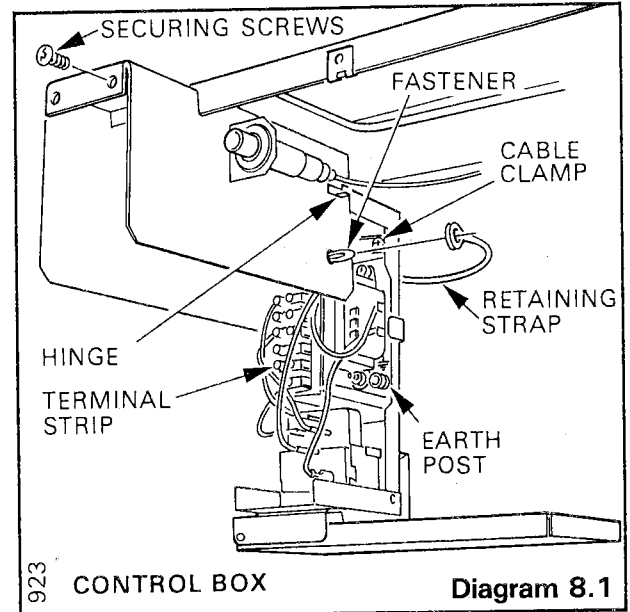

8.3 WIRING

All of the electrical installation must comply with I.E.E. Wiring Regulations and any local regulations which apply. All cable and connections must be of the approved type.

8.4 TESTING

In the event of an electrical fault after installation of the appliance, preliminary checks must be carried out, as described in the British Gas Multimeter Instruction Book.

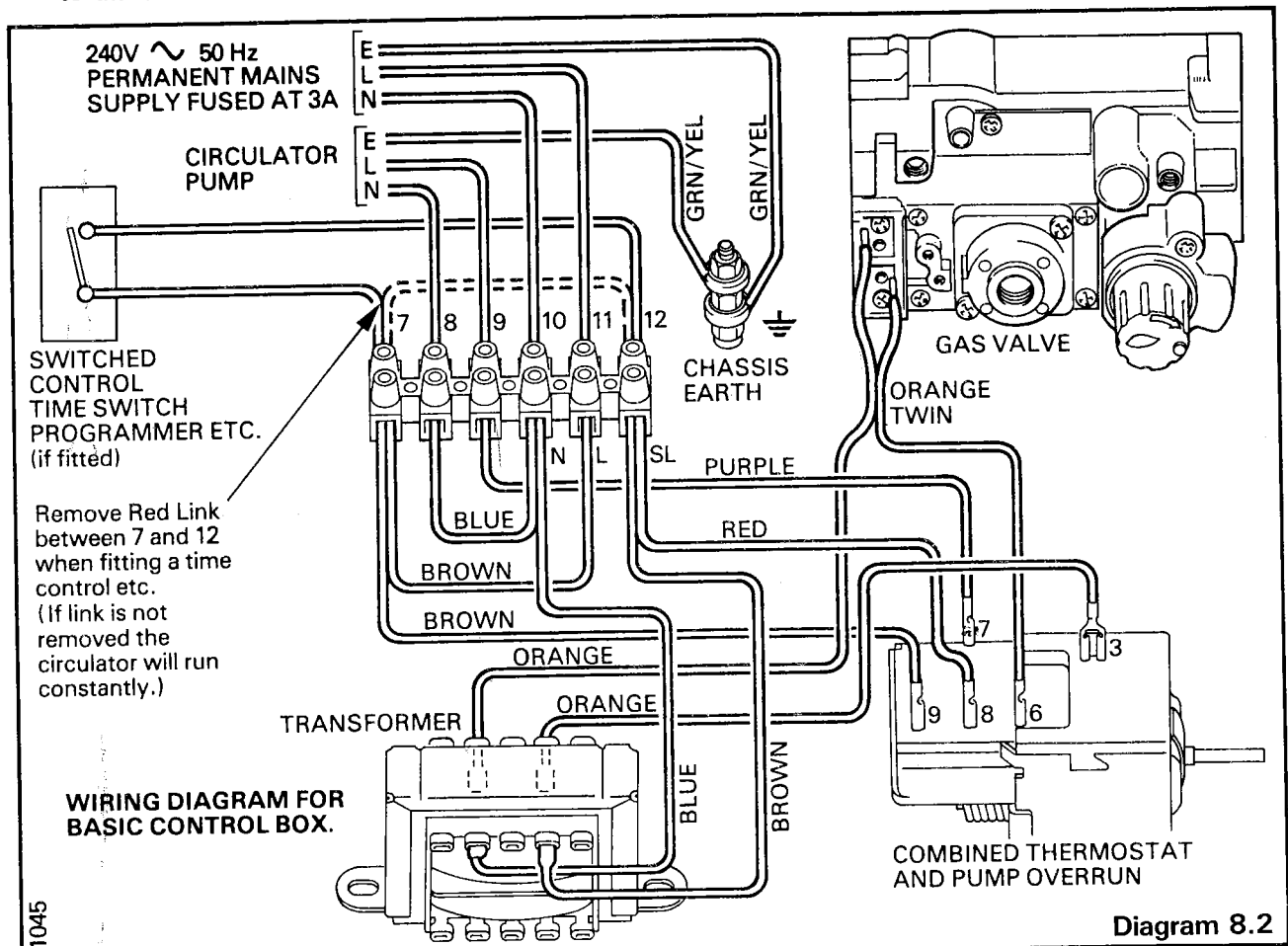

8.5 EXTERNAL CONTROLS AND SCHEMES

- 8.5.1 Remove the red link between 7 and 12 in the boiler control box when using any of the suggested schemes or switch control.
- 8.5.2 Any external boiler controls **must** only be wired to interrupt the link between terminal 7 and 12. The boiler requires a permanent mains supply as shown in diagram 8.2.
- 8.5.3 The pump **must** be wired to the boiler control box as shown.
- 8.5.4 All controls must be connected in accordance with the manufacturers' instructions.

8.5.5 THE INSTALLER IS REQUESTED TO ADVISE THE USER OF THE CONTROLS SCHEMES USED WITH THE BOILER AND TO GIVE GUIDANCE ON THE OPERATION OF THE CONTROLS.

8.6 CONTROL BOX SECURING

Replace the control box by engaging the rear hinge arrangement and raising the front of the box to secure with the two screws.

8.7 GLOW-WORM PROGRAMMER KIT

Installation and wiring instructions for the integral programmer are supplied with the kit.

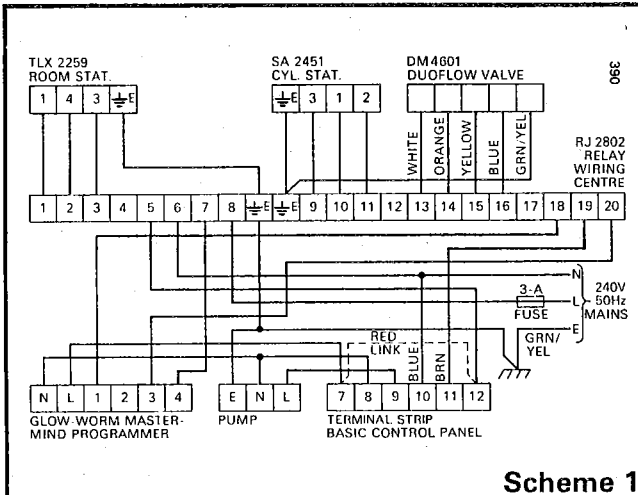

Scheme 1 Satchwell Duoflow system 16 position programmer. Remove links A and B from RJ2802 wiring centre.

Scheme 2 Independent control of hot water and heating, both pumped, using two motorised valves, 16 position programmer.

Scheme 3 Honeywell Sundial Plan Y. Follow Honeywell instructions for piping and controls installation.

Scheme 4 Pumped hot water and heating, using a Drayton Flow-share valve.

Scheme 5 Independent control of hot water and heating both pumped, using two spring return valves, 16 position programmer.

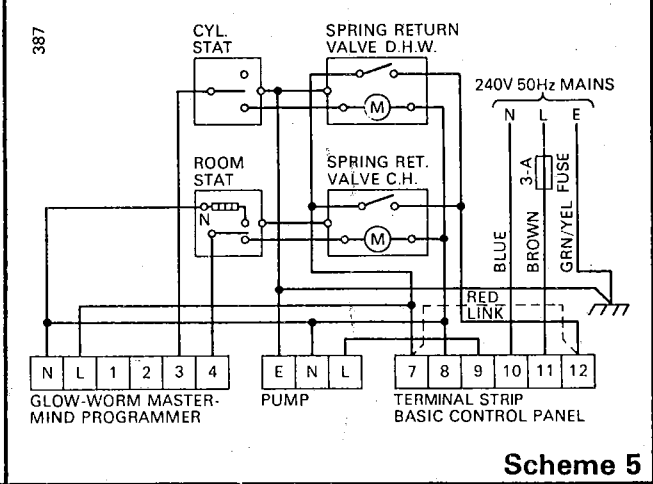
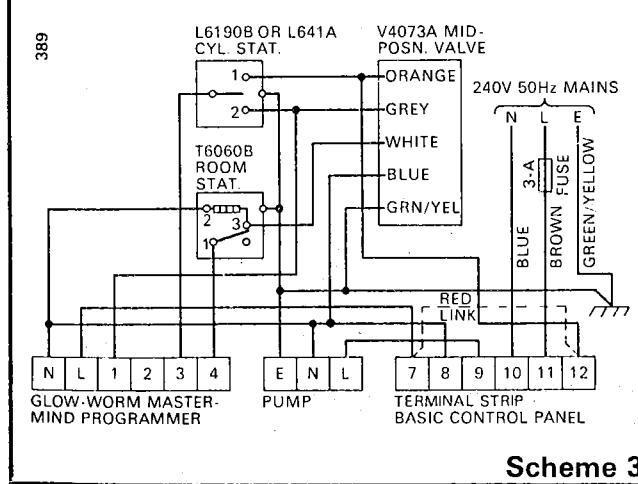
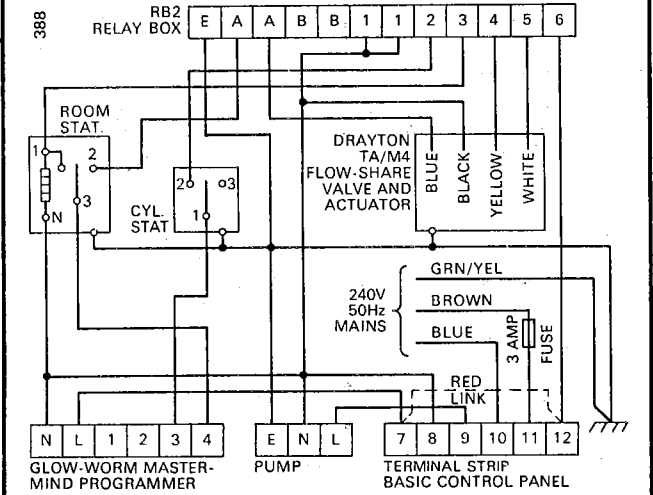
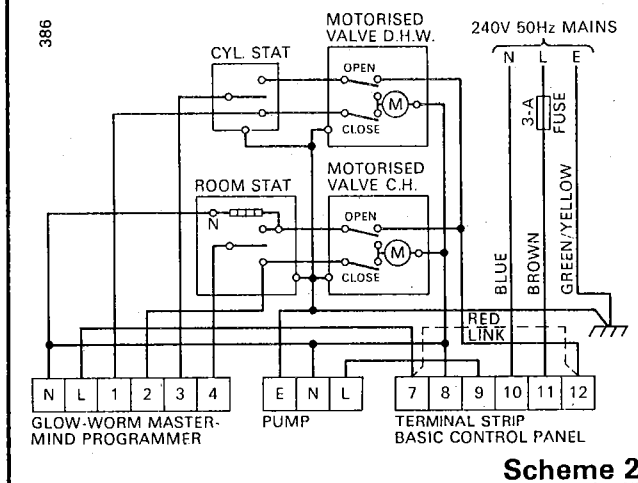

9 COMMISSIONING

1052

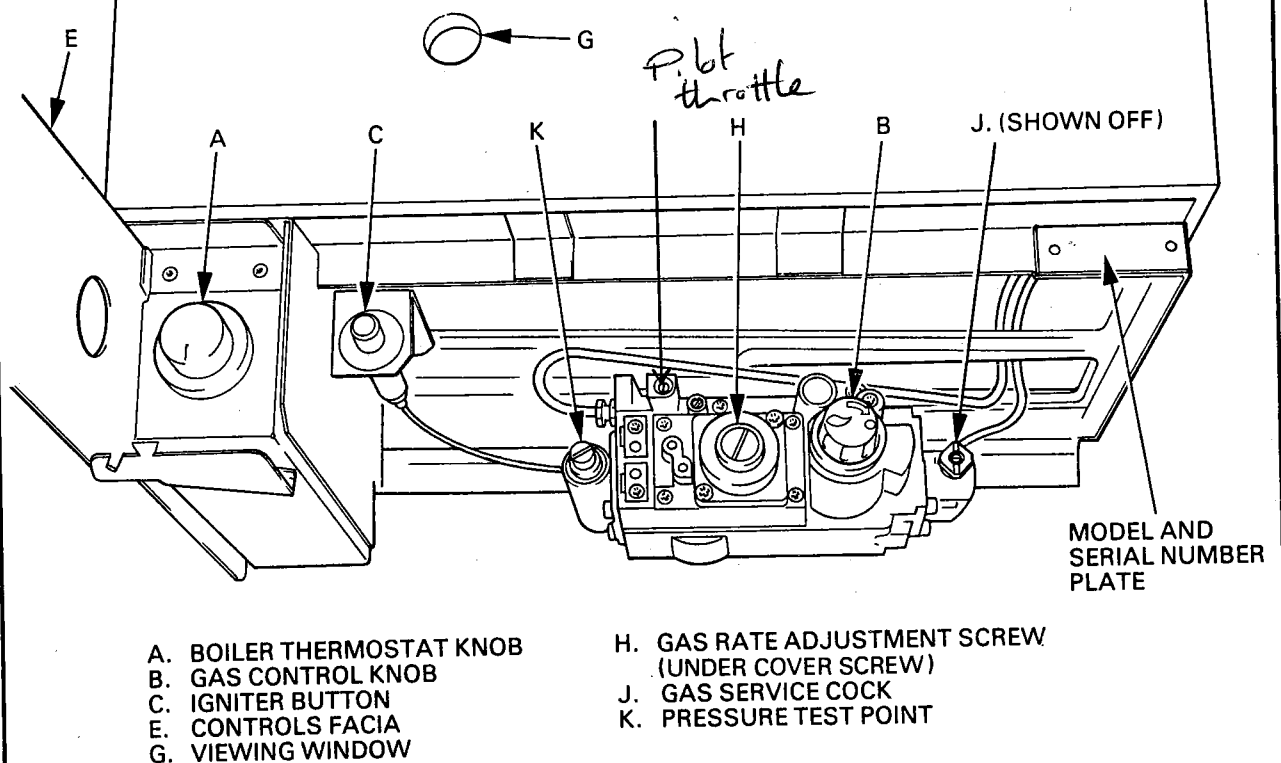

BOILER COMPONENTS.

Diagram 9.1

9.1 COMMISSIONING (Sealed systems only)

- 9.1.1 Flush the whole system with cold water and fill until the pressure gauge registers 1.5 bar (21.5 lbf/in²). Clear any air locks and check for water soundness.
- 9.1.2 Check the operation of the safety valve preferably by allowing the water pressure to rise until the valve lifts. This should be within 0.3 bar (\pm 4.3 lbf/in²) of the pre-set pressure. Where the above is not possible a manual check should be conducted.
- 9.1.3 Release cold water to initial system design pressure.
- 9.1.4 Any set pointer on the pressure gauge should be set to coincide with the indicating pointer.

9.2 COMMISSIONING (All systems)

- 9.2.1 Ensure that the system has been thoroughly flushed and is full of water and that all air is properly vented from the system, including the pump.
- 9.2.2 Before operating the appliance check that time clocks, room thermostats, domestic cylinder thermostats and other controls that may be used on the system are calling for heat and checked for correct operation.

9.3 INITIAL LIGHTING AND ADJUSTMENT

- 9.3.1 Refit the outer case. The optional tinted decorative front panel, if specified, should be fixed at this stage, see instructions supplied with panel.
- 9.3.2 Turn boiler thermostat to '0', the off position, see diagram 9.1.
- 9.3.3 For access to the gas valve pressure regulator, test point and igniter button, swing forward controls facia 'E'.
- 9.3.4 Remove gas pressure test point screw and fit a pressure gauge to test point 'K'.
- 9.3.5 Turn on the main electricity supply to the unit and check that the pump is circulating water through the unit.
- 9.3.6 OPEN ALL WINDOWS AND EXTINGUISH ANY MAKED LIGHTS IN THE ROOM. PUT OUT PIPES AND CIGARETTES.
- 9.3.7 **CAUTION:** The following procedure should be carried out by a qualified gas service engineer. Identify the boiler controls with relevant details on diagram 9.1.
- 9.3.8 Turn on main gas supply and purge air from the supply pipe in accordance with the recommendations on CP331 Part 3.
- 9.3.9 Turn boiler gas service cock 'J' to 'ON', with line horizontal.

9.3.10 Depress the gas valve control knob 'B' fully and hold. Depress and release the igniter button 'C' until the pilot burner lights. At this stage, air may be present in the gas pipes and this operation may need to be repeated until all air is expelled. When the pilot burner lights, check through the viewing window 'G', keep control knob 'B' fully pushed on for approx. 20 seconds to heat the thermocouple. If the pilot burner fails to light, or stay alight then repeat the sequence as above.

9.3.11 If the gas valve control knob 'B' is turned clockwise to its stop (in direction of arrow), to the off position, a safety lock prevents it being fully depressed again until the thermocouple has cooled, to stop attempted re-light in an unsafe condition. No attempt should be made to force knob 'B', this will rotate automatically to the lighting position.

9.3.12 Make sure that the burner pilot is alight and stable. Set any clock or programmer to an 'ON' position and ensure that any other controls are calling for duty.

9.3.13 Turn the thermostat knob 'A' fully clockwise and the main burner should ignite gradually, taking 3 to 5 seconds to reach full flame and can be seen through the viewing window 'G'. Check that there is adequate air for combustion; indicated by the correct appearance of the flames.

9.3.14 Test for gas soundness around the boiler components using a leak detection fluid.

9.3.15 To adjust the burner setting pressure remove the pressure regulator cover screw and adjust the internal screw 'H' to obtain the required heat input, see RANGE RATING table on page 2, for settings. Turn clockwise to increase pressure. Replace cover screw after setting.

9.3.16 Should any doubt exist about the gas rate, check that at the meter 10 minutes after lighting the boiler.

9.3.17 Swing back controls facia until it clicks into position and replace controls cover.

9.4 TESTING

9.4.1 Check the operation of the flame failure device on the boiler to ensure that the burner shuts down within 60 seconds.

9.4.2 Check the thermocouple output in millivolts with the thermocouple in both closed and open circuit, refer to FAULT FINDING, section 12.

9.5 FLUSHING

9.5.1 Allow the system to reach maximum working temperature and examine for water leaks.

9.5.2 The system should then be turned off and rapidly drained while hot.

9.5.3 Refill the system and vent all air as before.

9.6 SEALED SYSTEMS

Sealed systems should be adjusted to the initial design pressure. Any set pointer on the pressure gauge should be positioned to coincide with the indicating pointer.

9.7 ALL SYSTEMS - ADJUSTMENT

9.7.1 When commissioning the system the boiler should first be fired with the by-pass valve fully closed on full service i.e. central heating and domestic hot water. The system should then be balanced, adjusting the pump and lockshield valve as necessary. Having achieved a satisfactory condition operate the boiler with by-pass valve fully closed on minimum load, (normally this will be on 'central heating only' with one radiator, in the main living area, operating). The valve should be gradually opened to achieve the following flowrates:

Fuelsaver 60B MkII 18 litres/min (3.9 gal/min)

Fuelsaver 75B MkII 22.5 litres/min (4.9 gal/min)

9.7.2 The appropriate flow rate is equivalent to a temperature rise of 11°C, (20°F), across the boiler; if necessary re-adjust the pump. UNDER NO CIRCUMSTANCES MUST THIS VALVE BE LEFT IN THE FULLY CLOSED POSITION.

9.7.3 Operate the boiler again on full service and check that balancing is satisfactory; make further adjustments, if necessary.

9.7.4 If thermostatic radiator valves are fitted, care must be taken to ensure adequate flowrate when the valves close.

9.8 COMPLETION

9.8.1 Adjust the thermostat to the required setting, adjust systems controls to their required settings and instruct the user in the operation of the boiler and any system controls.

9.8.2 Hand the Users Instructions to the user or purchaser for retention. Instruct the efficient and safe operation of the boiler and heating/hot water system. Advise the user or purchaser that for continued efficient and safe operation of the boiler it is important that adequate servicing is carried out at intervals recommended by the local region of British Gas.

10 SERVICING

Servicing must be carried out by a competent person. Before commencing a service, turn off the gas supply at the main service cock and isolate the electricity supply.

10.1 HEATING BODY SERVICING

- 10.1.1 Remove controls cover by pulling forwards and clear of boiler.
- 10.1.2 Remove outer casing by undoing the screw at the bottom and unhooking at the top and the inner case by undoing the screws at top and bottom, see diagram 6.1.
- 10.1.3 Remove the flue hood by undoing the wing nuts holding the securing angle, see diagram 10.1 and remove the angle. Lift off the flue hood.
- 10.1.4 Remove the combustion chamber front panel by removing the wing nut at the bottom and the four screws securing it to the combustion chamber sides.
- 10.1.5 Remove the two screws and washers securing the pilot burner and pilot shield to the main burner, see diagram 10.2.
- 10.1.6 Pull the pilot assembly sufficiently forwards to allow the main burner to be disengaged from the injector. Raise the burner up through the combustion chamber and remove. Take care not to damage the insulation inside the combustion chamber and also the pilot burner and electrode assembly.
- 10.1.7 Brush any deposits from the heat exchanger and collect on a sheet of paper.

10.2 MAIN BURNER SERVICING

With the main burner removed as in section 10.1, brush or vacuum any deposits from the burner, ensuring that the flame ports are unobstructed. Brushes with metallic bristles must not be used.

10.3 SERVICE CHECKS

- 10.3.1 Check the main burner injector for blockage, damage and remove if necessary. Replace with a new sealing washer to ensure gas soundness.
- 10.3.2 Inspect the pilot burner, thermocouple and ignition electrode, clean if necessary. Check condition of components and spark gap, see diagram 10.3.

10.4 REASSEMBLY

- 10.4.1 Replace items in reverse order of removal.
- 10.4.2 When replacing main burner ensure that it is pushed fully home onto the injector and that the guides are engaged on the injector manifold.

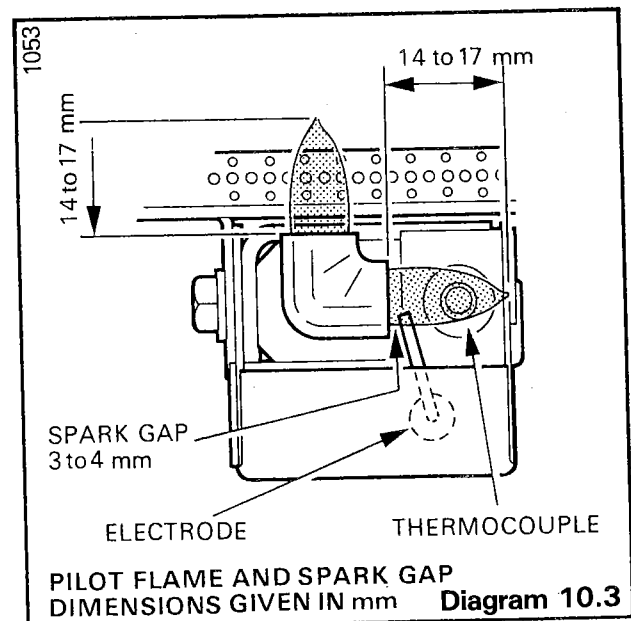
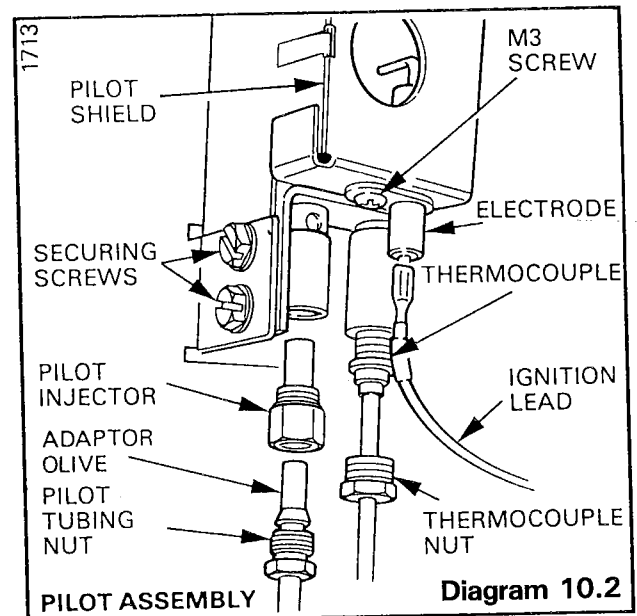
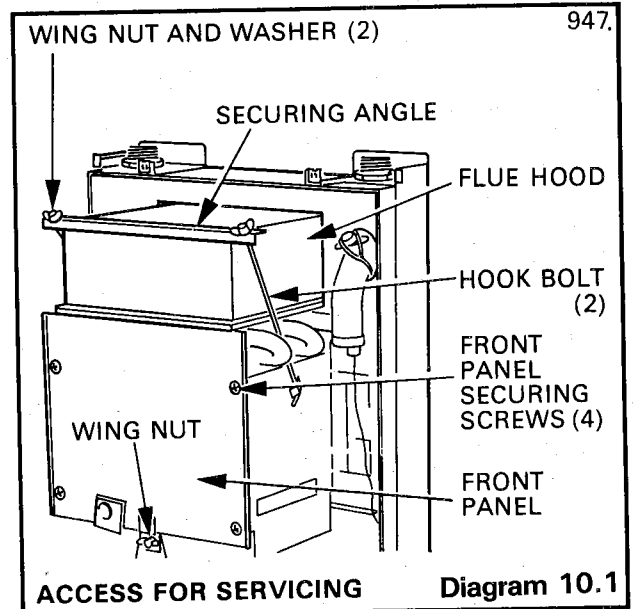

BEFORE REMOVING ANY PARTS, TURN OFF GAS SUPPLY AT MAIN SERVICE COCK AND ISOLATE ELECTRICAL SUPPLY. ALWAYS TEST FOR GAS SOUNDNESS AFTER COMPLETING A SERVICE.

11.1 MAIN INJECTOR

- 11.1.1 With the main burner removed as in section 10, the injector, at the rear of the combustion chamber, can be unscrewed and replaced as necessary using a new sealing washer.
- 11.1.2 When replacing main burner ensure that it is pushed fully home onto injector and that the guides are engaged on the injector manifold.

11.2 PILOT BURNER AND PILOT INJECTOR

- 11.2.1 Remove controls cover by pulling forwards and clear of appliance.
- 11.2.2 Remove outer casing by undoing the screw at the bottom and unhooking at the top and the inner case by undoing the screws at top and bottom. see diagram 6.1.
- 11.2.3 Pull off ignition lead from electrode, see diagram 10.2.
- 11.2.4 Unscrew the tubing nut at the base of the pilot burner, releasing the pilot tube.
- 11.2.5 Remove the pilot injector by unscrewing it from the pilot burner.
- 11.2.6 Release the wing nuts securing the flue hood, see diagram 10.1.
- 11.2.7 Remove the combustion chamber front panel, as in paragraph 10.1.4.
- 11.2.8 Remove the two screws and washers securing the pilot burner and pilot shield to the main burner, see diagram 10.2.
- 11.2.9 Remove pilot shield complete with electrode.
- 11.2.10 Unscrew the thermocouple nut.
- 11.2.11 The pilot burner can now be lifted away.
- 11.2.12 Take care not to damage the electrode. When replacing, ensure that the spark gap is as shown in diagram 10.3.

11.3 THERMOCOUPLE

- 11.3.1 Follow instructions 11.2.1 to 11.2.3.
- 11.3.2 Unscrew the thermocouple nut.
- 11.3.3 Release the two screws securing the front and rear gland plates, (do not remove these screws). Pull forward the front gland plate, see diagram 11.1.
- 11.3.4 Undo thermocouple connection at interrupter at rear of gas valve and remove clips attaching it to the pilot pipe. The thermocouple can now be removed.

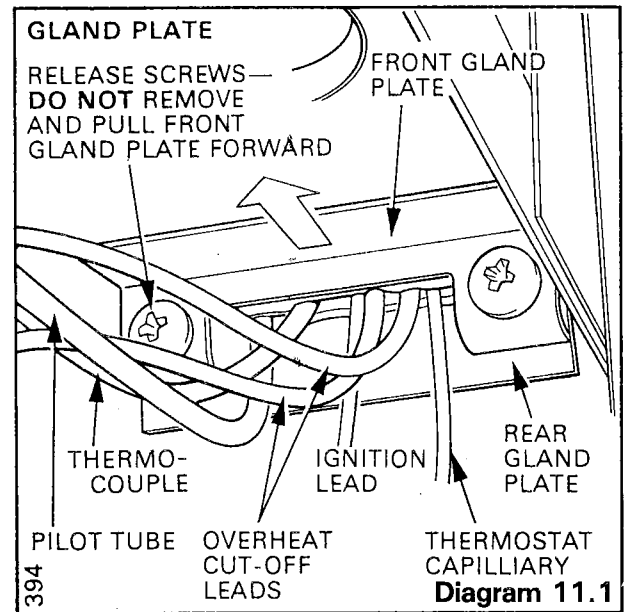

- 11.3.5 Bend the replacement thermocouple to match the discarded one. No bending radius should be less than 12mm internal.
- 11.3.6 Refit thermocouple to the interrupter, check that the connectors from the overheat cut-off are in place in the interrupter and held by the thermocouple nut. Do not overtighten.
- 11.3.7 If there is insufficient access at the right-hand side of the appliance, re-engagement of the thermocouple and overheat cut-off connectors are blind operations. In this instance, it is recommended that the inner case is removed, refer to 'SERVICING' section 10.
- 11.3.8 After refitting, check that the electrode gap is as shown in diagram 10.3.
- 11.4 ELECTRODE**
- 11.4.1 Follow instructions 11.2.1 to 11.2.3.
- 11.4.2 Electrode can now be unscrewed from the pilot shield.
- 11.4.3 When replacing, check that the electrode gap is as shown in diagram 10.3.

11 REPLACEMENT OF PARTS

11.5 OVERHEAT CUT-OFF

11.5.1 Remove controls cover and casings as described in 11.2.1 and 11.2.2. Remove flue hood as in 10.1.3.

11.5.2 Remove the two screws securing the overheat cut-off to the clamp, see diagram 11.2.

11.5.3 Release the connectors at the interrupter at the rear of the gas valve by slackening the thermocouple nut, see diagram 11.3.

11.5.4 Release the two screws securing the front and rear gland plates (do not remove these screws), see diagram 11.1, then withdraw the cables of the overheat cut-off.

11.5.5 When refitting, smear heat sink compound supplied between the face of the overheat cut-off and the water connection pipe, making sure that it is located on to the heating body pipe correctly.

11.5.6 If there is insufficient access at the right-hand side of the boiler, re-engagement of the thermocouple and overheat cut-off connectors are blind operations. In this instance, it is recommended that the inner case is removed, refer to 'SERVICING' section 10.

11.6 GAS VALVE

11.6.1 Remove controls cover by pulling forwards, clear of appliance.

11.6.2 Swing forwards control fascia.

11.6.3 Remove outer case by releasing the screws at the bottom and unhooking at the top.

11.6.4 Unscrew thermocouple connection and remove the overheat cut-off connectors from the thermocouple interrupter, see diagram 11.3.

11.6.5 Disconnect the gas valve connectors from the gas valve by pulling from the valve.

11.6.6 Release the two screws securing the front and rear gland plates, see diagram 11.1, disconnect the pilot tube nut and withdraw the pilot tube from the gas valve.

11.6.7 Remove the four hex socket head screws from the gas service cock flange with a hexagon key wrench, (Allen Key).

11.6.8 Support the gas valve and remove the two socket head screws and two extended hexagon screws securing the gas valve to the burner supply pipe flange.

11.6.9 Ease the valve clear of the flanged connections and discard both 'O' rings.

11.6.10 Transfer the thermocouple interrupter to the replacement valve, hand tighten the thermocouple interrupter to the valve and finally tighten one quarter turn to leave the interrupter black insert facing vertical, see diagram 11.3.

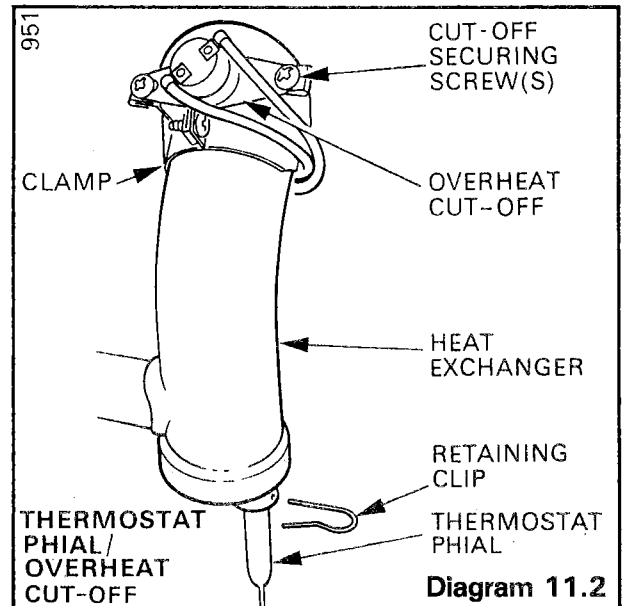

Diagram 11.2

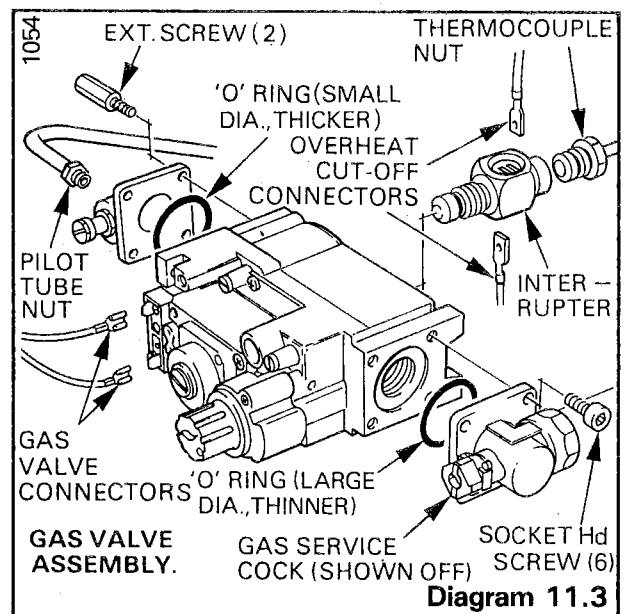

Diagram 11.3

11.6.11 Reassemble the valve to the gas service cock flange using the new, larger, thinner 'O' ring supplied. Ensure the valve is the correct way round. Direction of flow is indicated by an arrow on the valve.

11.6.12 If there is insufficient access at the right-hand side of the boiler, refer to paragraph 11.5.6.

11.6.13 Fit the new, smaller, thicker 'O' ring supplied between the gas valve and burner supply pipe flange, see diagram 11.3, ensuring that it is correctly located in the recess in the valve. Fit the special extended hexagon screws at the top.

11.6.14 Re-connect the pilot supply to the gas valve and secure the gland plates.

11.6.15 Re-connect the gas control valve connectors, see diagram 8.2 for wiring.

11.6.16 Recommission boiler by referring to 'COMMISSIONING' section 9.

11.7 HEATING BODY

- 11.7.1 Remove controls cover and casings as in 11.2.1 and 11.2.2.
- 11.7.2 Remove flue hood and combustion chamber front as in 10.1.3 and 10.1.4.
- 11.7.3 Remove retaining clip from thermostat phial pocket and withdraw phial from pocket, see diagram 11.2. Do not wipe off heat sink compound.
- 11.7.4 Remove the two screws attaching the overheat cut-off to the clamp. Remove the screw securing the clamp to the water outlet pipe and remove the clamp, see diagram 11.2.
- 11.7.5 Remove the two screws securing the flue duct, and remove, see diagram 11.4 for the 60B or 11.5 for the 75B model.
- 11.7.6 Drain the heating circuit of water (a drain cock is usually found at the lowest point of the heating system). A drain point is provided for heat exchanger draining.
- 11.7.7 Remove the three screws securing the sealing plate to the back panel.
- 11.7.8 Disconnect the flow and return connections and the locknuts on the flow and return bulkhead fittings, see diagram 11.4.
- 11.7.9 Remove the four screws holding combustion chamber to the back panel and lower the combustion chamber to rest on the base of the appliance.
- 11.7.10 Disengage the heating body connections, withdrawing the connections through the air duct.
- 11.7.11 Replace washers and locknuts to the flow and return bulkhead fittings.
- 11.7.12 Ensure that the flats on the hexagon connections engage in the locations inside the air duct.
- 11.7.13 Make sure that the tabs on the top edge of the combustion chamber locate into the slots in the heat exchanger end plates.
- 11.7.14 Replace combustion chamber front - do not tighten the securing screws.
- 11.7.15 Replace flue duct - do not tighten the securing screws.
- 11.7.16 Replace overheat cut-off and thermostat phial. When replacing these components smear with heatsink compound supplied. Ensure that the thermostat phial is secured in the pocket with the retainer and that the overheat cut-off is fastened to the clamp and located on the heating pipe correctly.
- 11.7.17 Replace flue hood with securing angle, hook bolts and wing nuts, tighten firmly but do not overtighten.
- 11.7.18 Tighten all the loosely fitted screws.

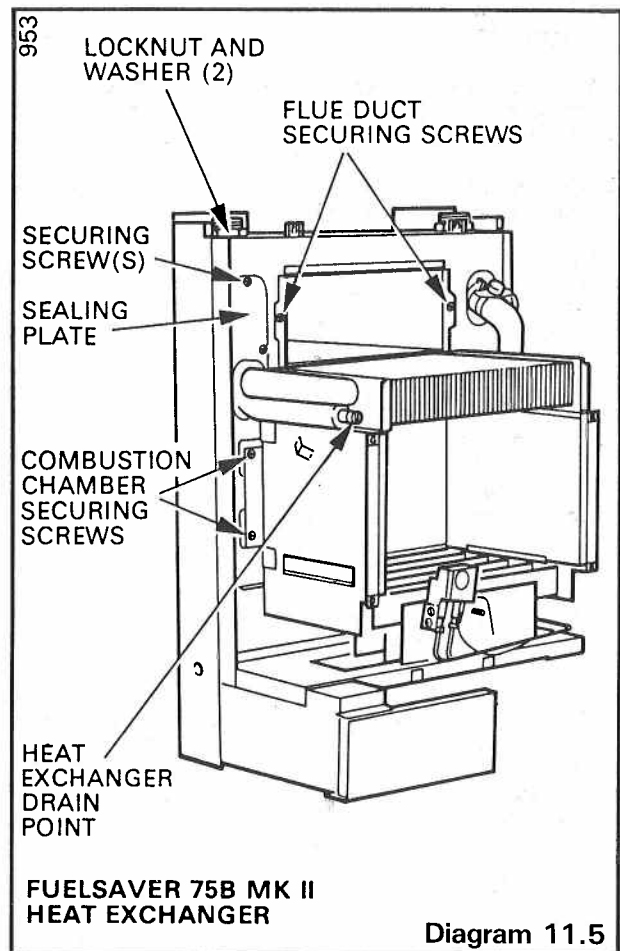
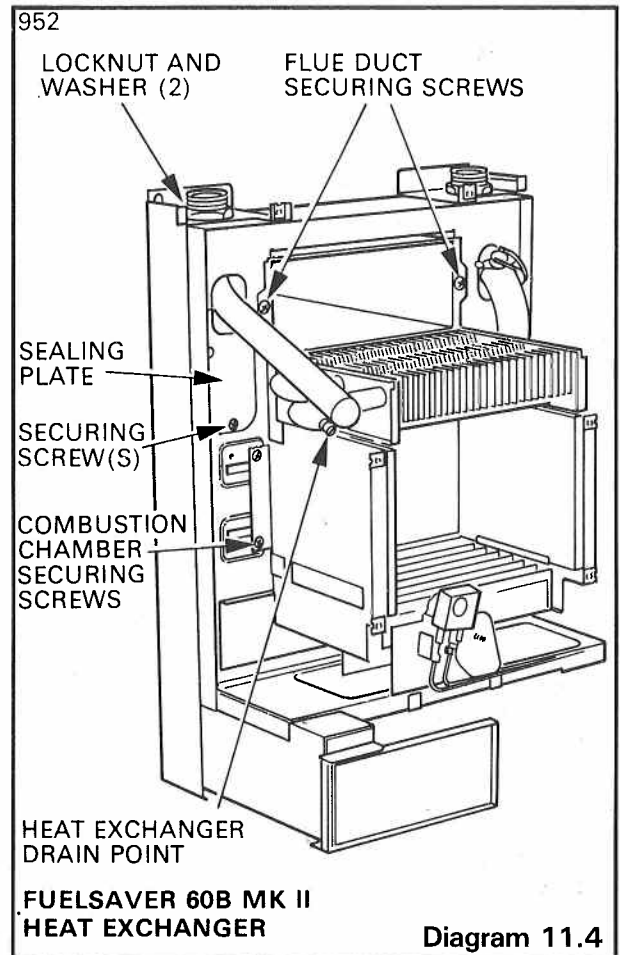

11 REPLACEMENT OF PARTS

11.8 ELECTRICAL CONTROL BOX

- 11.8.1 Remove controls cover and casings as described in 11.2.1 and 11.2.2.
- 11.8.2 Remove retaining clip from boiler thermostat phial pocket and withdraw the phial from the pocket, see diagram 11.2.
- 11.8.3 Release the two screws securing the front and rear gland plates, (do not remove these screws). Pull forward the front gland plate, see diagram 11.1.
- 11.8.4 Remove the control box by undoing the two fixing screws at the front above the facia, and lower the front of the box until it is clear of its cover, see diagram 8.1. Pull the retaining strap off the fastener. Push box towards the rear of appliance to disengage its hinging at the rear, and lower the box. Withdraw the thermostat capillary through the bottom of the air duct.
- 11.8.5 Disconnect electrical leads (a) mains L,N,SL and E at terminal block No's 11, 10, 12 and earth stud. (b) pump at terminal block No's 8, 9 and earth stud. (c) disconnect connectors at gas valve. (d) disconnect any remote controls at terminal 7 and 12.
- 11.8.6 Replace in reverse order, for details of wiring see diagram 8.2. When replacing the thermostat phial, smear it with heat sink compound and ensure that it is secured in the pocket by the retainer.
- 11.8.7 IF PROGRAMMER FITTED - Remove the controls facia by pulling off the plastic cap from the pivot pin and remove the pivot pin, see diagram 11.6. Disconnect electrical leads to secondary controls and any bridging wires between the two 6-way terminal blocks. Note the termination of all wires. Undo the two screws and nuts securing the programmer cable harness and 6-way terminal block. Remove programmer, facia and harness from control box.

11.9 BOILER THERMOSTAT

- 11.9.1 Follow instructions 11.8.1 to 11.8.4.
- 11.9.2 Swing forward controls facia and remove the thermostat control knob.
- 11.9.3 Slacken the screw securing the thermostat capillary clip to the control box and release the capillary.
- 11.9.4 Pull off the connections from the thermostat terminals. Remove the two screws securing the thermostat to the control box. The thermostat may now be removed, withdrawing the capillary through the bottom of the air duct.
- 11.9.5 When replacing, smear the thermostat phial with heat sink compound supplied before replacing in the pocket. Ensure that it is secured by the retainer.

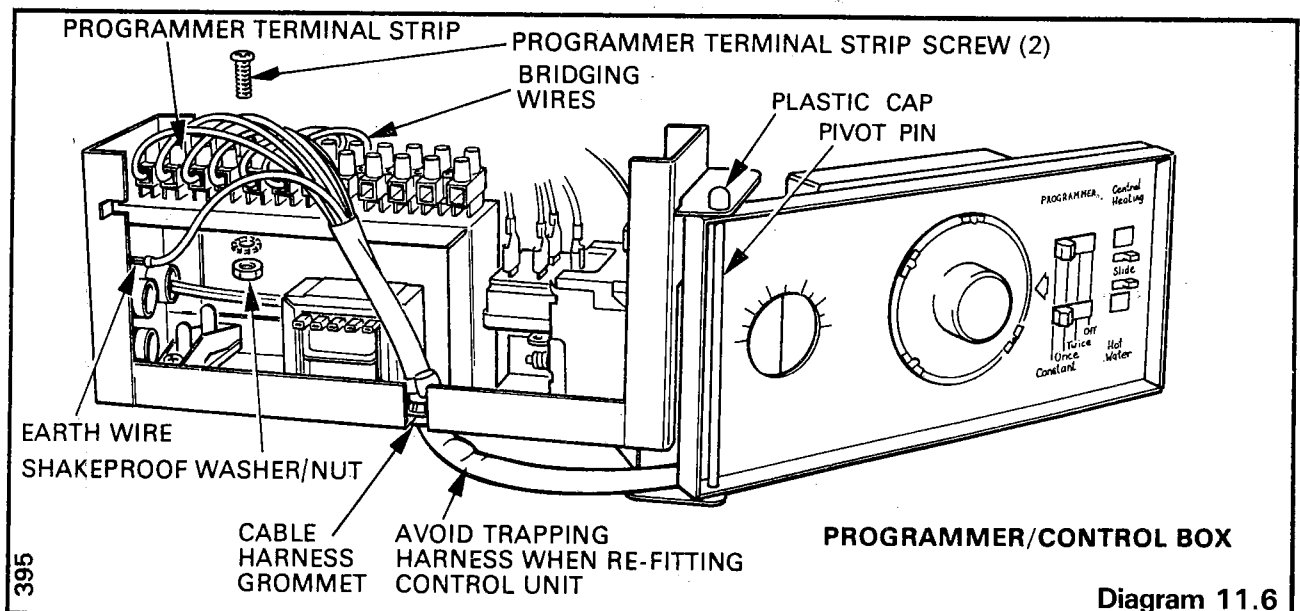

11.10 PIEZO UNIT

- 11.10.1 Remove controls cover by pulling forwards and clear of appliance.
- 11.10.2 Swing forward controls facia.
- 11.10.3 Pull off ignition lead from the tag on the piezo unit.
- 11.10.4 Undo the backing nut from the body of the piezo unit and remove the unit.

11.11 IGNITION LEAD

- 11.11.1 Remove controls cover and casings as described in 11.2.1 and 11.2.2.
- 11.11.2 Release the two screws securing the front and rear gland plates, (do not remove these screws). Pull forward the front gland plate, see diagram 11.1.
- 11.11.3 Pull off ignition lead from tag on electrode.
- 11.11.4 Pull off ignition (clear end) lead from the tag on the piezo unit, the lead can now be removed.

11.12 COMBUSTION CHAMBER INSULATION

- 11.12.1 **Front Insulation** - Follow instructions of paragraphs 10.1.1, 10.1.2 and 10.1.4.
- 11.12.2 Remove the insulation screw from front panel of the combustion chamber; see diagram 11.7 for the 60B or 11.8 for 75B model. Slide out the insulation panel.
- 11.12.3 **Side Insulation** - Follow instructions of paragraphs 10.1.1, 10.1.2 and 10.1.4.
- 11.12.4 Slide out the side insulation panels.
- 11.12.5 **Rear Insulation** - Follow instructions of paragraphs 10.1.1 to 10.1.6 to remove casings, front panel, pilot and main burners.
- 11.12.6 Remove screws securing the combustion chamber sides to the back panel, see diagram 11.4 for the 60B or 11.5 for the 75B model. Lower the combustion chamber to rest on the base of the appliance.
- 11.12.7 Remove the rear combustion chamber insulation.

11.13 PROGRAMMER (IF FITTED)

- 11.13.1 Hinge open controls facia and loosen the two screws 'A' securing electrical box on back of programmer.
- 11.13.2 Remove two screws 'B' securing programmer to controls facia, see diagram 11.9.

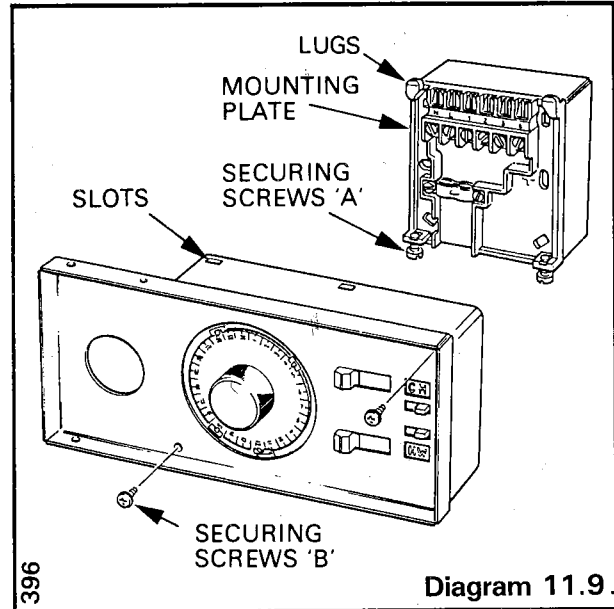
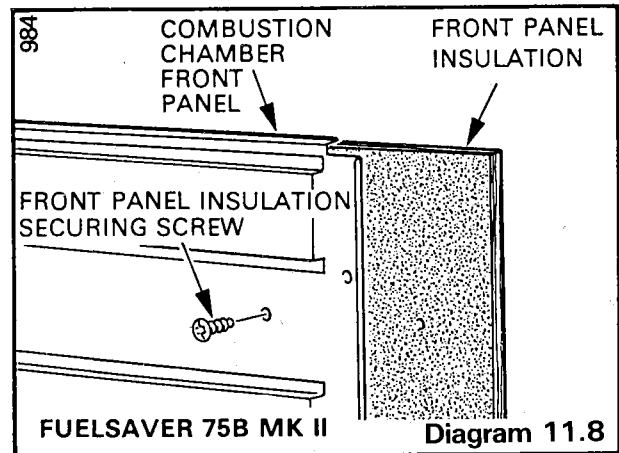
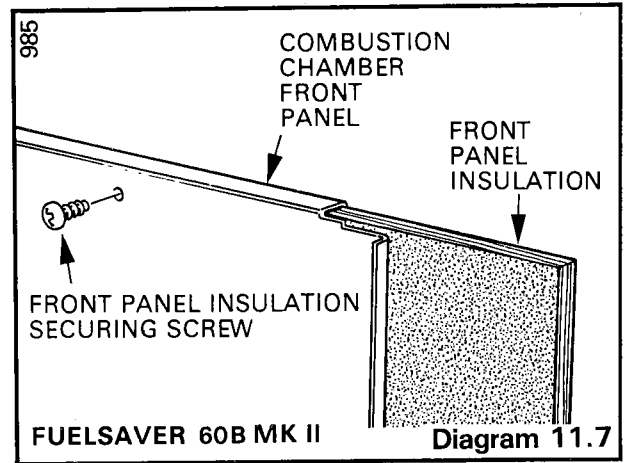

12 FAULT FINDING

12.1 THERMOCOUPLE

12.1.1 To test the thermocouple, a meter with a range of 0 to 30 mV is required similar to the B.G.C. (Minitest 6) Multimeter.

12.1.2 **Close Circuit** - With the pilot lit connect one crocodile clip to the thermocouple capillary as close as possible to the thermocouple nut which is fastened into the interrupter, see diagram 12.1. Connect the other lead to the connector held interrupter nearest to the gas valve, then take millivoltage reading.

12.1.3 **Open Circuit** - Disconnect the thermocouple nut from the interrupter. Connect crocodile clip to thermocouple capillary and connect the other lead to the capillary core. Hold in gas control knob and light pilot, keeping the control knob held until the thermocouple millivoltage has settled, to take reading.

12.1.4 Refer to thermocouple diagnosis graph, diagram 12.2 when using the chart, diagram 12.3.

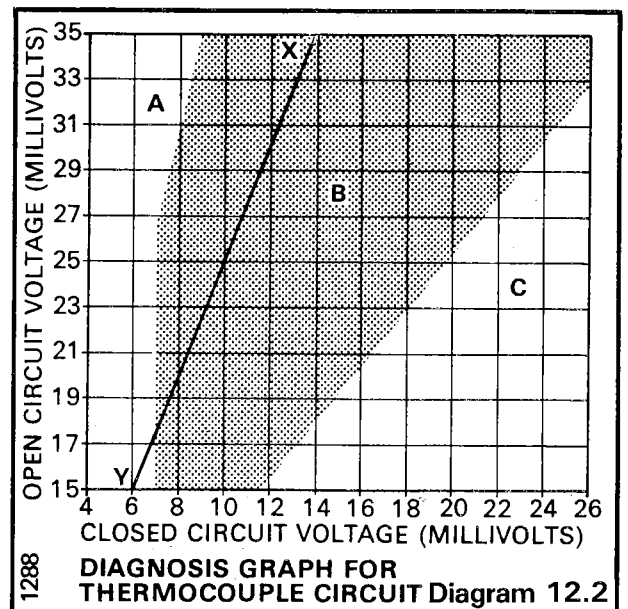
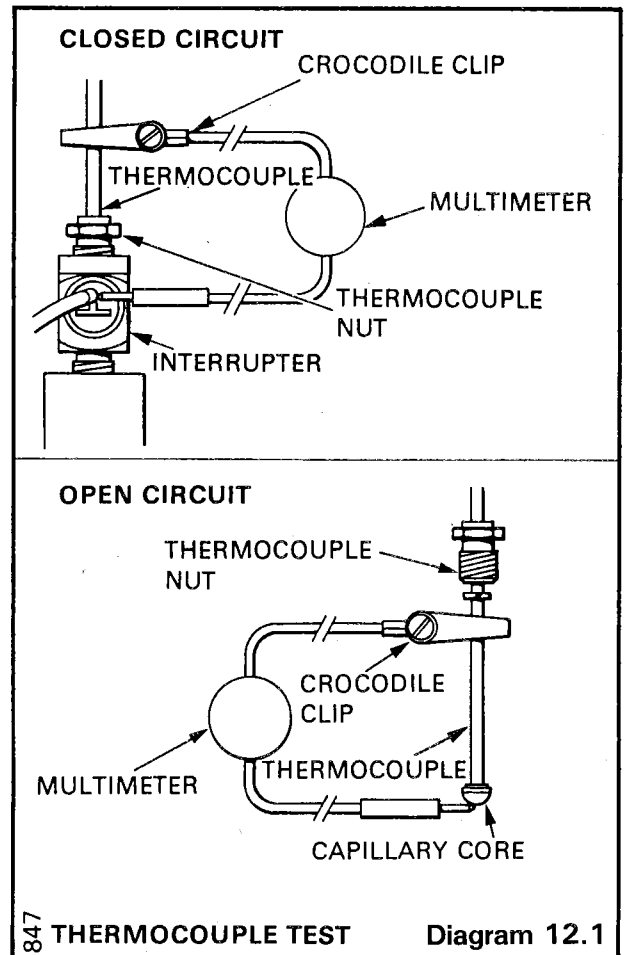

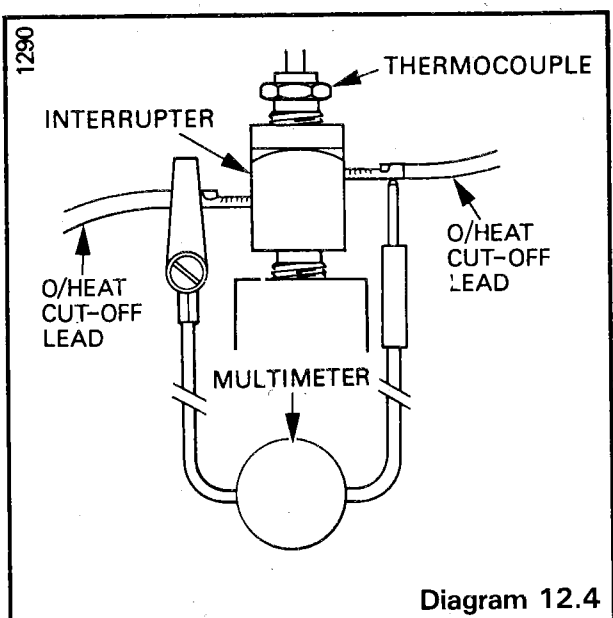
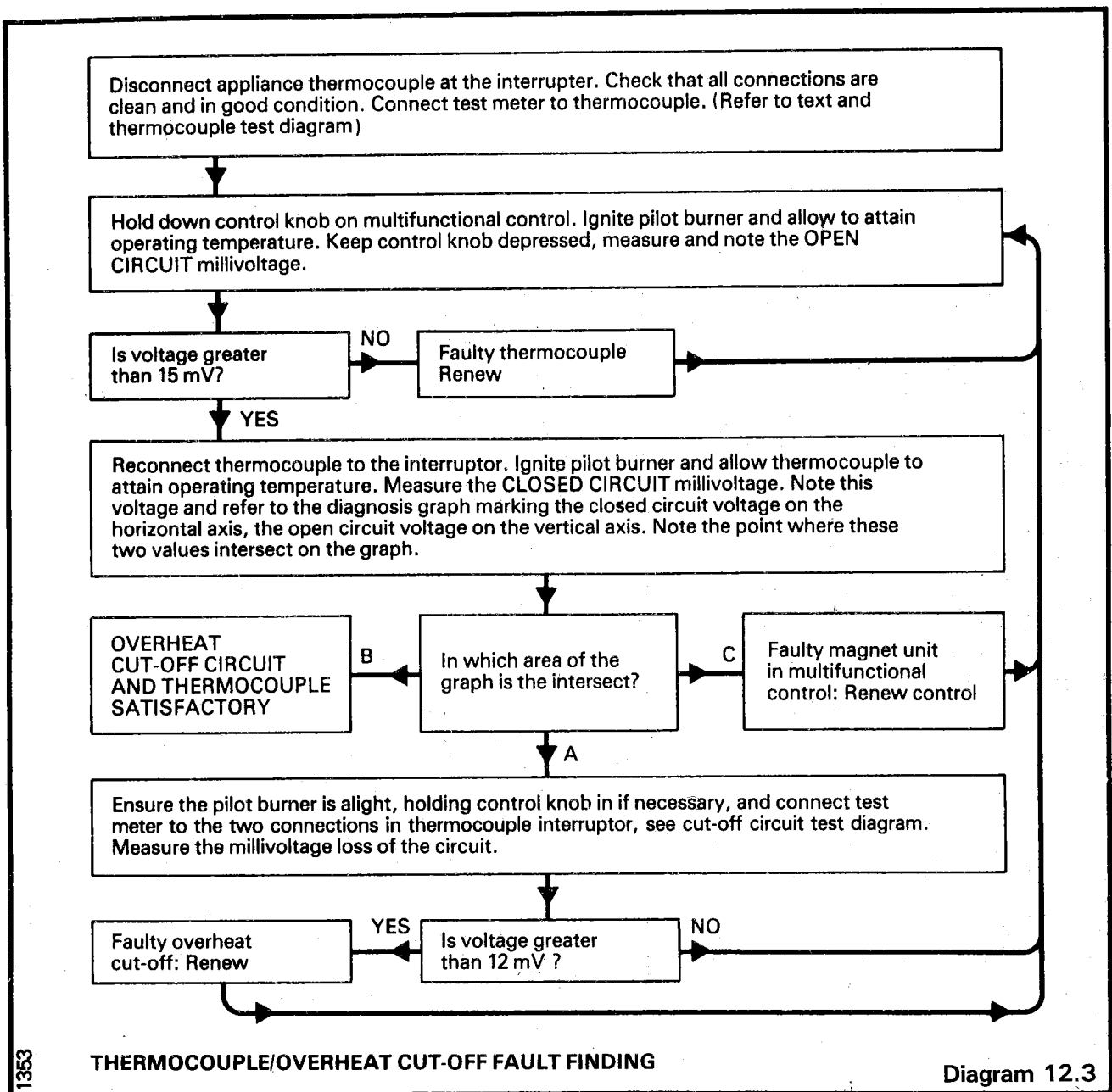

12.2 OVERHEAT CUT-OFF

12.2.1 With the pilot burner lit, by holding in the gas control knob if necessary, connect multimeter to the two terminals either side of the thermocouple interrupter, see diagram 12.4.

12.2.2 Take the millivoltage drop reading and refer to thermocouple/overheat cut-off fault finding diagram 12.3.

12 FAULT FINDING

12.3 ELECTRICAL

IMPORTANT:- The preliminary electrical system checks contained in the British Gas Multimeter instructions book are the first checks to be carried out during a fault finding procedure. On completion of the service/fault-finding task which has required the breaking and re-making of electrical connections then the checks 'A' Earth continuity, 'C' Polarity and 'D' Resistance to Earth must be repeated.

12.3.1 To check boiler thermostat, transformer and multi-functional control, see diagram 12.5 and functional flow wiring diagram 12.6 for basic or 12.7 for programmer models.

12.3.2 To check thermostat pump over-run circuit see diagram 12.8 and functional flow wiring diagram 12.6 for basic or 12.7 for programmer models.

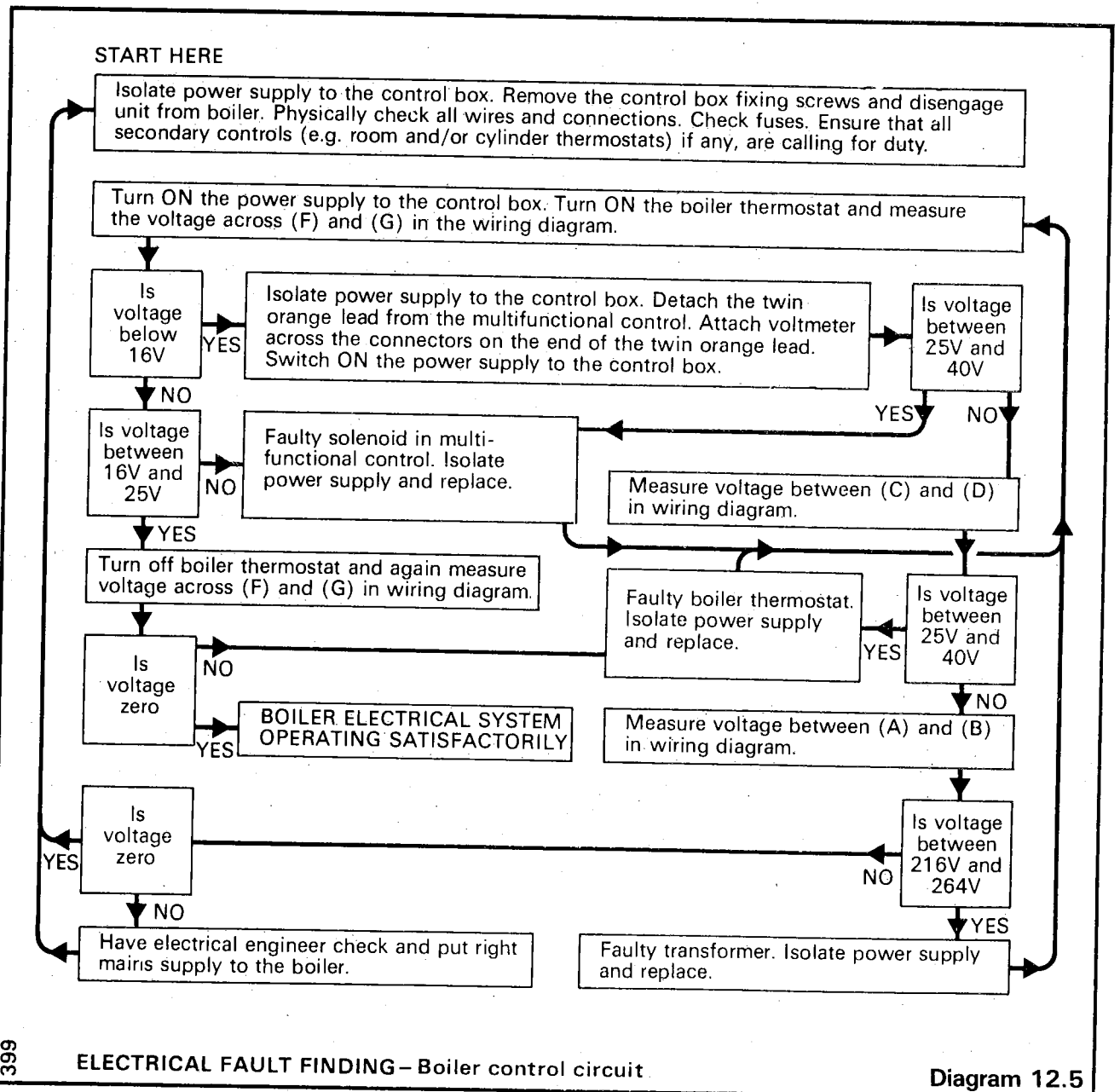

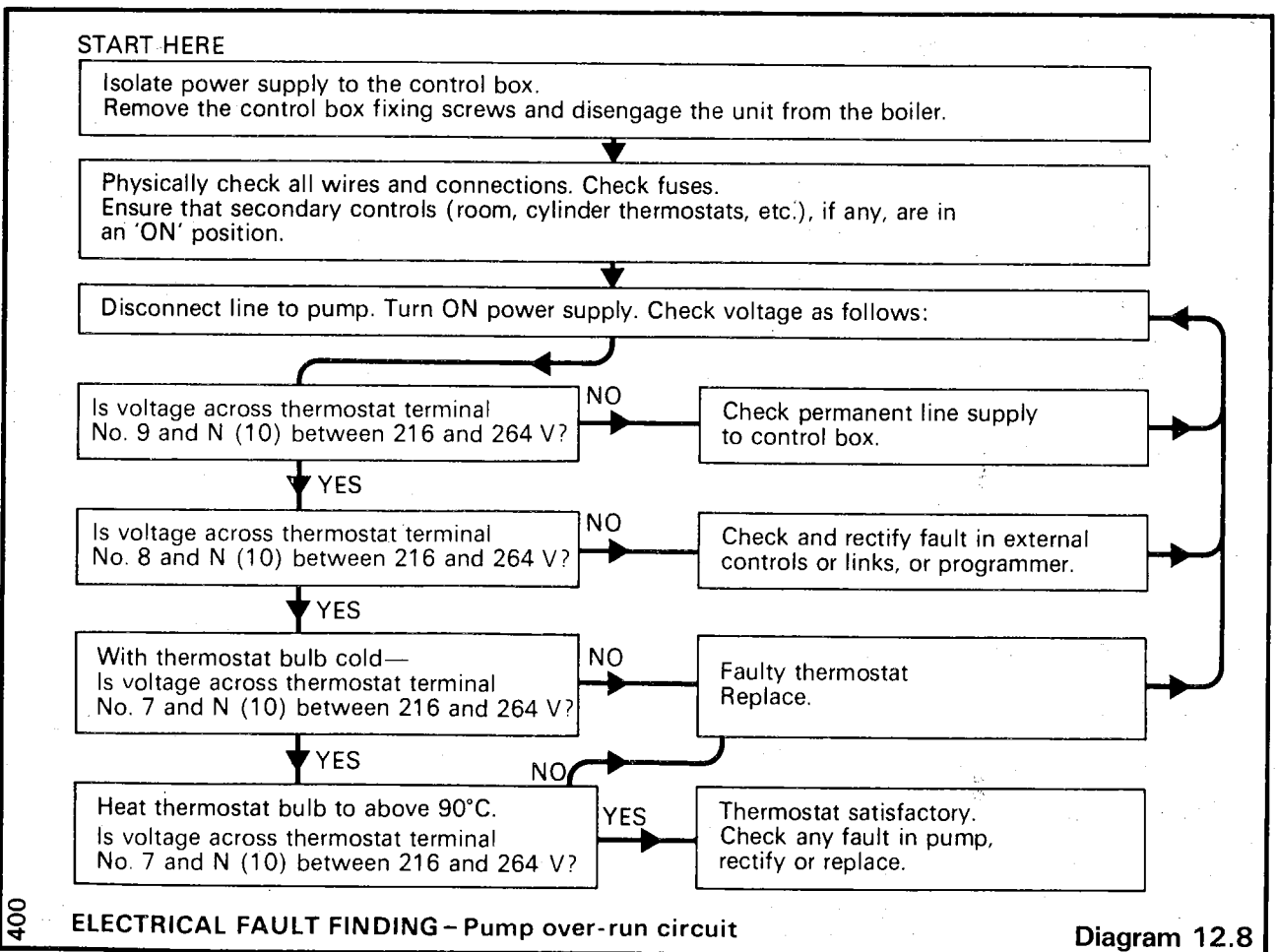
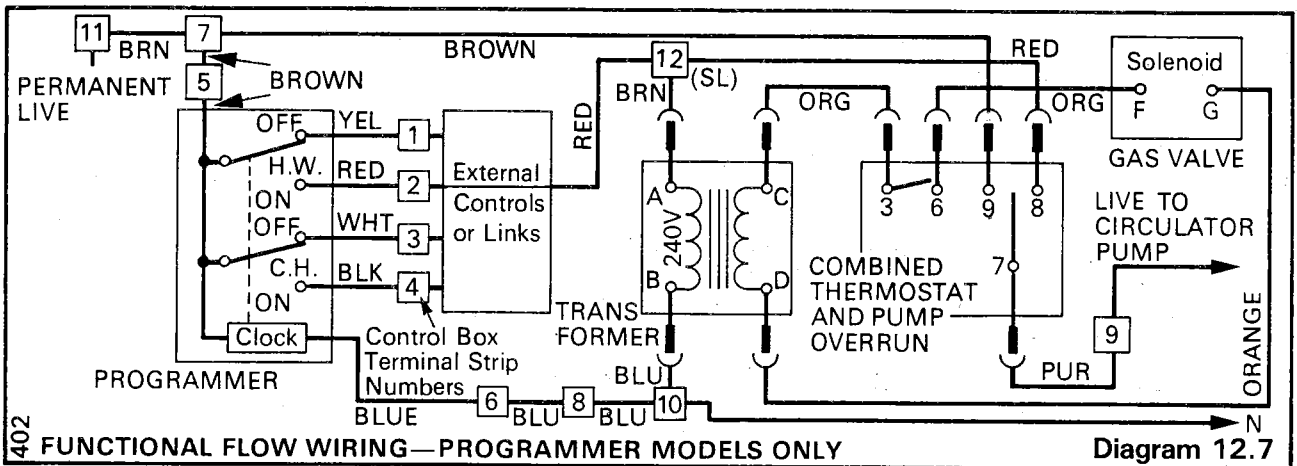
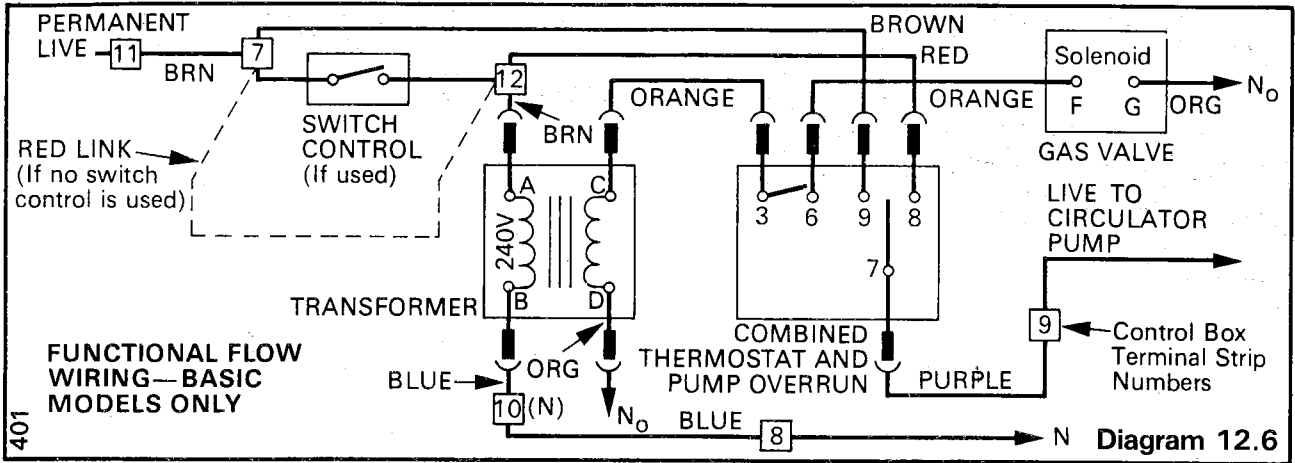

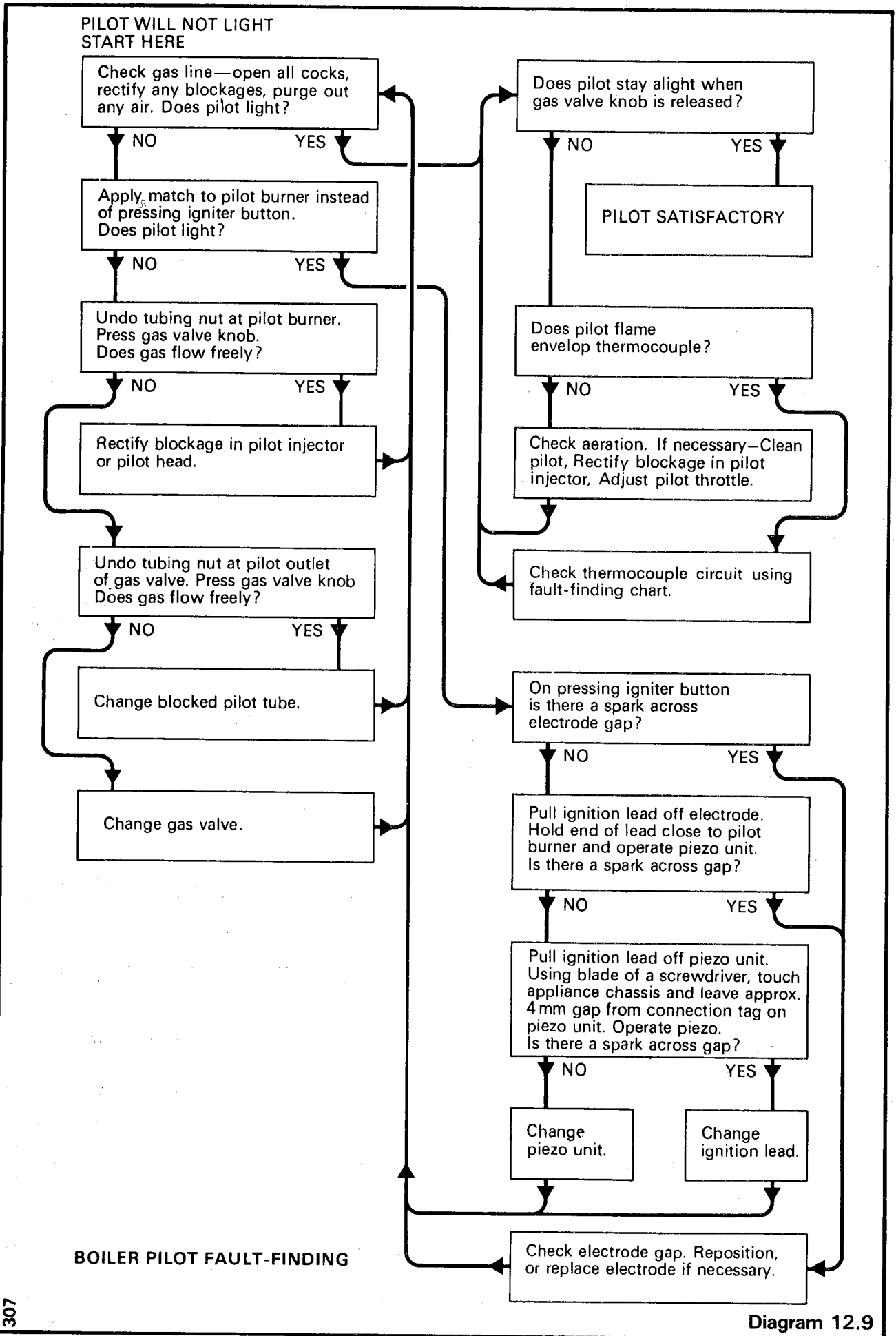

307

FAULT AND CAUSE	REMEDY
12.4 PILOT GOES OUT AFTER A PERIOD OF REMAINING ALIGHT	
12.4.1 Inner case not correctly fitted.	Fit case correctly.
12.4.2 Flue parts not fitted or sealed properly.	Seal cavity or fit flue parts correctly as described in installation instructions.
12.4.3 Electrical supply failure causing overheat cut-off to operate.	Relight pilot.
12.4.4 Overheat cut-off operating.	Refer to 12.6.
12.4.5 Pump incorrectly connected.	Connect pump in accordance with diagram 8.2.
12.5 MAIN BURNER WILL NOT IGNITE	
12.5.1 External, remote controls not calling for duty.	Check that any remote, external controls are calling for duty.
12.5.2 Boiler thermostat not on.	Check boiler thermostat is in an "ON" position. See also 12.3.
12.6 THERMOSTAT WILL NOT CUT OUT	
12.6.1 Thermostat phial not fitted in pocket.	Fit phial in pocket.
12.6.2 Faulty thermostat.	Replace thermostat.
12.7 OVERHEAT CUT-OFF OPERATES PREMATURELY	
12.7.1 Air in heating body.	Vent system. Alter system layout if necessary.
12.7.2 Water circulation low or stopped.	Pump not functioning correctly. Check pump is wired directly to boiler. Alter system if necessary.
12.7.3 Overheat cut-off operates before boiler cycles on max boiler thermostat setting.	Change faulty overheat cut-off.
12.7.4 Correctly set overheat cut-off operates prematurely. 12.7.1 and 12.7.2 are satisfactory.	Change faulty heating body.
12.8 INSUFFICIENT HEAT	
12.8.1 Thermostat set too "LOW".	Increase setting.
12.8.2 Inlet gas pressure inadequate	Increase gas pressure.
12.8.3 Governor setting incorrect. (ensure thermostat is on maximum setting)	Check burner pressure against data badge. Reset only if more than 10% away from required figure.
12.9 APPLIANCE NOISY IN OPERATION *	
12.9.1 Overgassed	Check burner pressure against data badge and adjust only if more than 10% away from stated required figure.
12.9.2 Complete lack of water flow.	Check system controls for correct installation or correct type of controls.
12.9.3 Air in system.	Remove air from system. When system is first commissioned the air dissolved may take some time to boil out, therefore attempts should be made to vent air during the first weeks of the installation. Check venting of system as air bubbles can remain suspended in the water if system is not well vented.
12.9.4 Water flow rate.	Check that flow rate is correct. Check that pump is correct size and is correctly adjusted. By-pass not fitted or correctly set.

* There remains on most boilers a residual noise more noticeable at high temperatures. Normal operation of the boiler over a period should remove most noise.

13 SPARE PARTS

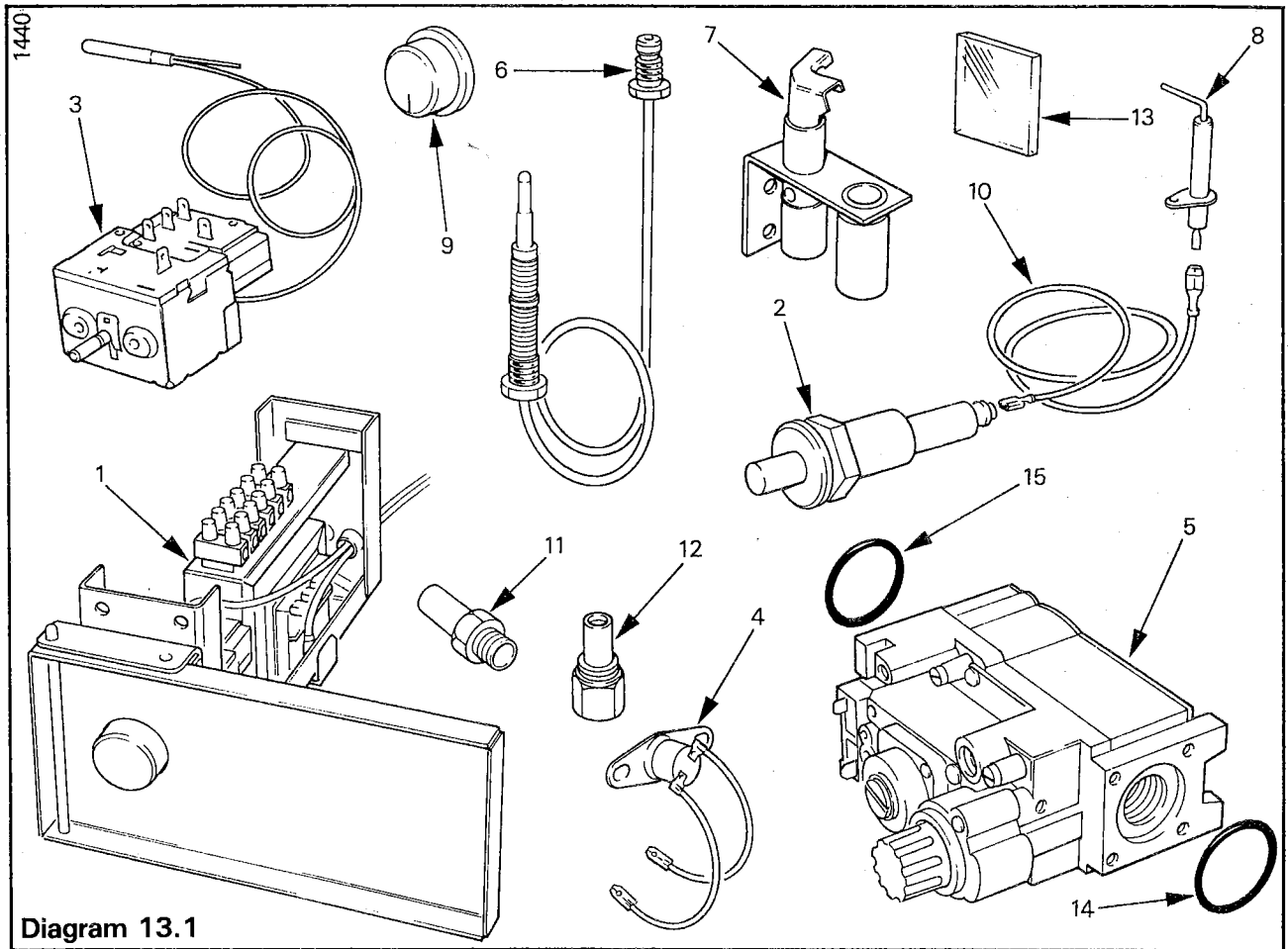

Diagram 13.1

Key No.	Glow-worm Part No.	Description	G.C. Part No.
1	416030	Electrical control box	355 386
2	900501	Piezo unit	-
3	416189	Boiler thermostat assembly	384 145
4	416188	Overheat cut-off assembly	-
5	416213	Gas valve assembly - Honeywell (incl. 14 & 15)	-
6	202405	Thermocouple	-
7	203415	Pilot burner - Johnson (incl. 12)	-
8	202600	Electrode	384 149
9	416144	Thermostat knob	355 401
10	WW4608	Ignition lead	393 744
11	203028	Boiler injector, marked 3.8 - 301700 (FS 60B MkII)	389 238
11	203027	Boiler injector, marked 4.1 (FS 75B MkII)	398 239
12	203509	Pilot injector - Johnson	-
13	411194	Sight glass	355 153
14	212031	'O' ring - gas valve/cock	-
15	208068	'O' ring - gas valve/test point	-

13.1 PART IDENTIFICATION

The key number in the first column of this list will help you identify each part in diagram 13.1.

13.2 ORDERING

When ordering spare parts, quote the part number and description, stating model number and serial number off the plate, see diagram 9.1. Local regions of British Gas should also include the G.C. number of the part.

Because of our constant endeavour for improvement, details may vary slightly from those quoted in these instructions.

DG Disc 4/16

719



TI Glow-worm Ltd
A member of the TI Group



Nottingham Road, Belper, Derby DE5 1JT
Telephone Belper (077 382) 4141
Telex 37586