

# Glow-worm

AA074L/6/82

Installation and Servicing Instructions

To be left with user, or at gas meter

## SPACE SAVER 50B Mk II Balanced Flue Boiler

G.C. Number 41 315 71

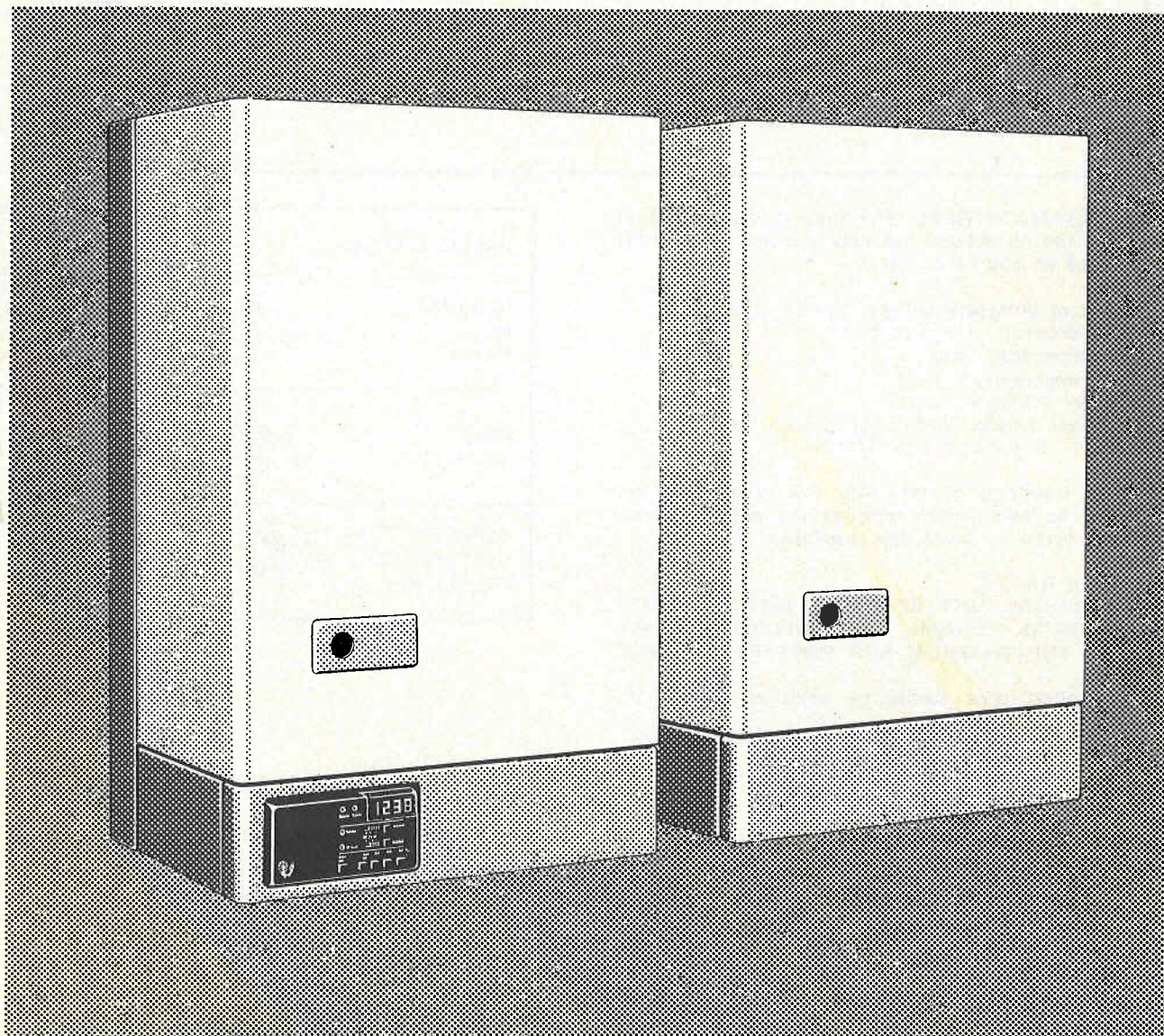

# 1 GENERAL

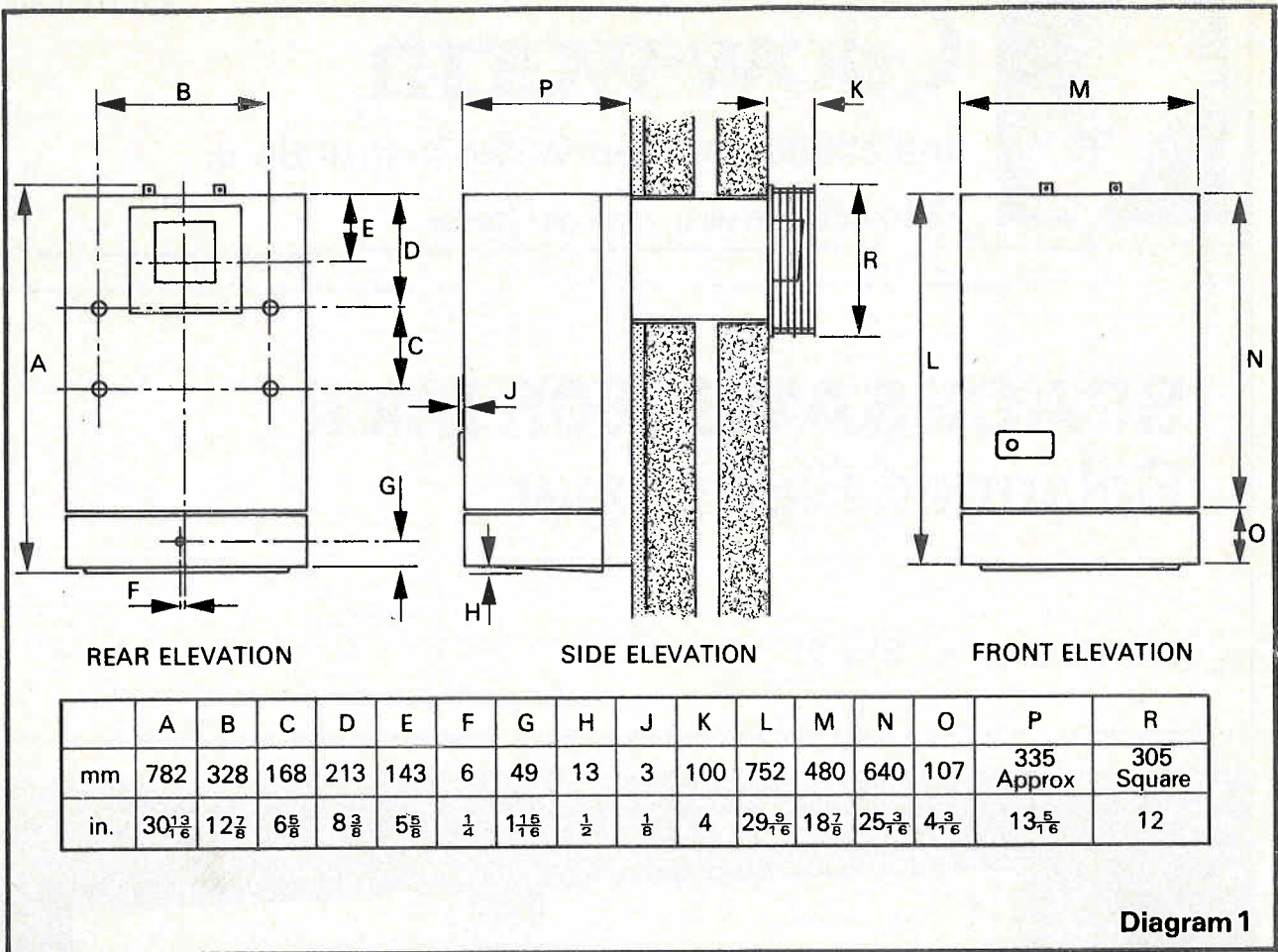

**IMPORTANT NOTICE:** The Space-Saver 50B-Mk.11 is for use on natural gas only and MUST NOT be used on any other gas.

Weight of complete boiler: 62.8Kg (138.5lb)  
 Water content: 6.4 litre (1.4 gal)  
 Gas connection: Rc $\frac{1}{2}$   
 Water connection: Rp1  
 Injector: 3.3mm dia. hole  
 Electrical supply: 240V, 50Hz, A.C. fused 3A  
 Burner: Aeromatic type 7/5 2001.

When installing or servicing this appliance, care should be taken when handling the edges of sheet metal parts, to avoid any possibility of injury.

### RANGE RATING

THIS BOILER MAY BE RANGE RATED TO SUIT INDIVIDUAL SYSTEMS. THE FOLLOWING TABLE GIVES THE MAXIMUM AND MINIMUM OUTPUTS.

The boiler input should be adjusted to suit the system requirements.

| RANGE RATING            |                    | min               | max               |
|-------------------------|--------------------|-------------------|-------------------|
| NOMINAL HEAT INPUT      | kW<br>(Btu/h)      | 15.32<br>(52,300) | 19.03<br>(64,900) |
| HEAT OUTPUT             | kW<br>(Btu/h)      | 11.72<br>(40,000) | 14.65<br>(50,000) |
| BURNER SETTING PRESSURE | mbar<br>(in. w.g.) | 10.5<br>(4.2)     | 17.0<br>(6.8)     |

## 1. GENERAL

It is essential that the boiler is installed strictly in accordance with the instructions in this booklet and the attention of the installer is drawn in particular to the following points.

### 1.1 STATUTORY REQUIREMENTS

THE INSTALLATION OF THIS BOILER MUST BE CARRIED OUT BY A COMPETENT PERSON AND MUST BE IN ACCORDANCE WITH THE RELEVANT REQUIREMENTS OF THE GAS SAFETY REGULATIONS, BUILDING REGULATIONS, I.E.E. REGULATIONS AND THE BYELAWS OF THE LOCAL WATER UNDERTAKING. DETAILED RECOMMENDATIONS ARE CONTAINED IN THE FOLLOWING BRITISH STANDARD CODES OF PRACTICE, CP 331 PART 3: 1974, BS 5376 PART 2: 1976, BS 5440 PART 1: 1978, BS 5440 PART 2: 1976, BS 5449 PART 1: 1977 AND BS 5546: 1979.

### 1.2 GAS SUPPLY

Installation pipes should be fitted in accordance with CP 331 : 3 : 1974. Pipework from the meter to the boiler must be of adequate size. Pipes of a smaller size than the boiler inlet gas connection should not be used. The complete installation must be tested for soundness as described in the above code.

### 1.3 ELECTRICAL

All electrical wiring must be carried out by a qualified electrician. All external components shall be of the approved type and shall be wired in accordance with the I.E.E. regulations and any local regulations which apply. The boiler must be earthed and connections to the mains supply should preferably be through an unswitched shuttered socket outlet and 3 amp fused 3 pin plug. Alternatively, a 3 amp fused double pole isolating switch or 3 amp fused spur box serving only the boiler may be used. Heat resistant cable of at least 3 amp (16/0.20) capacity, having a temperature rating of 90°C minimum must be used for all wiring to the control box.

### 1.4 WATER SYSTEM

This boiler shall only be connected to a cistern water supply, with a head not exceeding 27 metres (ninety feet) and having an open vent in the system. For all systems supplying domestic hot water the cylinder must be indirect.

The boiler MUST NOT be connected to a sealed system.

### 1.5 BOILER LOCATION

The boiler position should be such that the following minimum clearances are provided as shown in diagram 3:

Right and left hand side of boiler - 6mm ( $\frac{1}{4}$  in)  
 Top of boiler - 108mm ( $4\frac{1}{4}$  in) from top of casing  
 Below boiler - 100mm (4 in)

The boiler may be installed in any room, although particular attention is drawn to the requirements of the I.E.E. regulations and in Scotland, the electrical provision of the building regulations applicable in Scotland, with respect to the installation of the boiler in a room containing a bath or shower. Where the installation of the boiler will be in an unusual location, special procedures may be necessary and BS 5376 : 2 : 1976 gives detailed guidance on this aspect.

A compartment used to enclose the boiler must be designed and constructed specifically for this purpose. An existing cupboard or compartment may be used providing that it is modified for the purpose.

Details of essential features of cupboards/compartment design, including airing cupboard installations are given in BS 5376:2:1976.

## 2 FLUEING AND VENTILATION

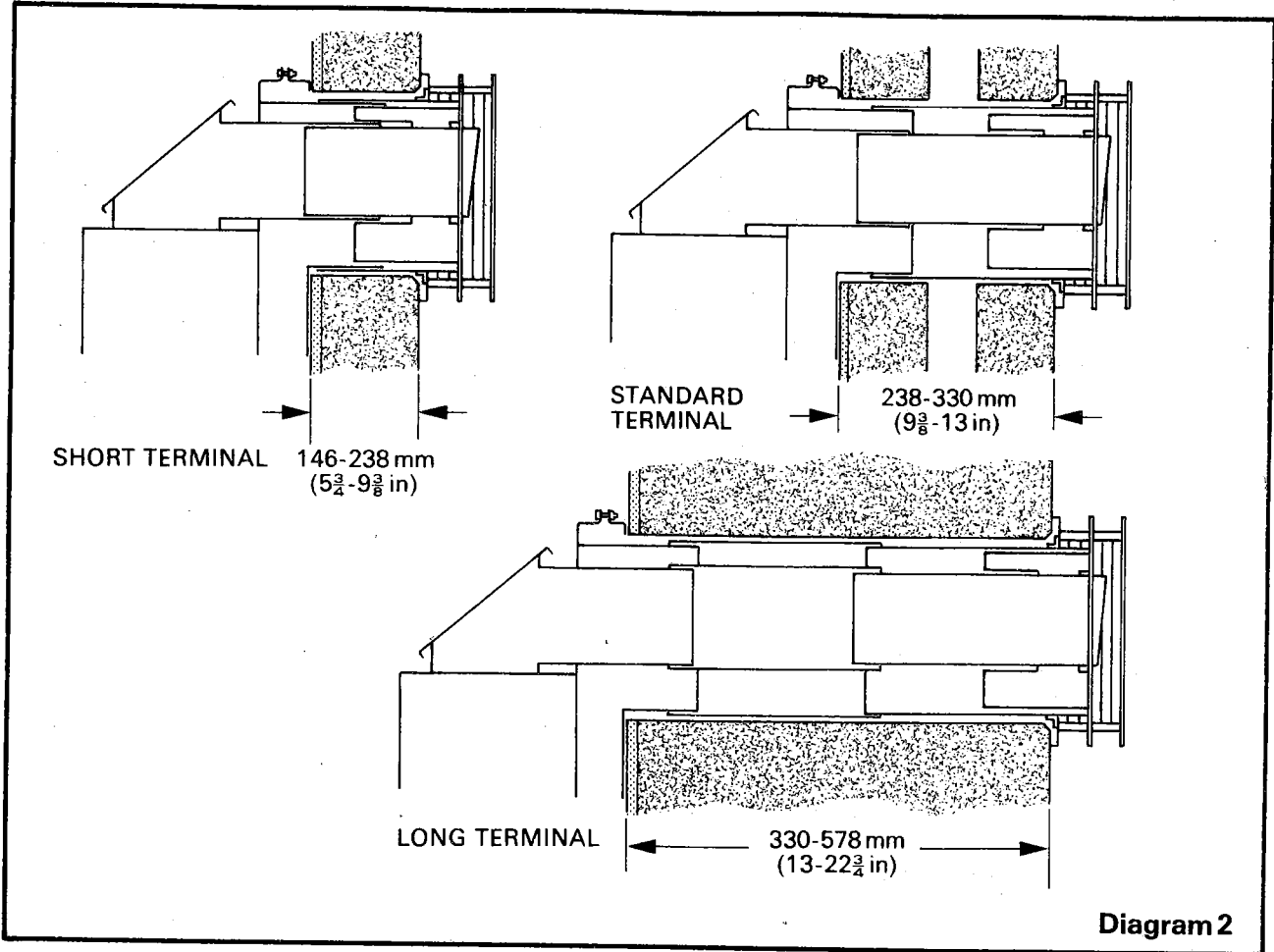

| TERMINAL POSITION   | MINIMUM SPACING |      |
|---|-----------------|------|
|   | mm              | (in) |
| 1 DIRECTLY BELOW AN OPENABLE WINDOW, AIR VENT, OR ANY OTHER VENTILATION OPENING | 300             | (12) |
| 2 BELOW GUTTERING   | 300             | (12) |
| 3 BELOW A BALCONY   | 600             | (24) |
| 4 BELOW EAVES   | 300             | (12) |
| 5 ABOVE ADJACENT GROUND OR BALCONY LEVEL  | 300             | (12) |
| 6 FROM DRAIN PIPES AND SOIL PIPES   | 75              | (3)  |
| 7 FROM INTERNAL OR EXTERNAL CORNERS   | 600             | (24) |
| 8 FROM A SURFACE FACING A TERMINAL  | 600             | (24) |
| 9 FROM A TERMINAL FACING A TERMINAL   | 600             | (24) |

| POSITION OF AIR VENTS | AIR FROM ROOM       |                         | AIR DIRECT FROM OUTSIDE |                         |
|-----------------------|---------------------|-------------------------|-------------------------|-------------------------|
|                       | PER kW INPUT        | (PER 5,000 Btu/h INPUT) | PER kW INPUT            | (PER 5,000 Btu/h INPUT) |
| HIGH AND LOW LEVEL    | 9.0 cm <sup>2</sup> | (2 in <sup>2</sup> )    | 4.5 cm <sup>2</sup>     | (1 in <sup>2</sup> )    |

**2. FLUEING AND VENTILATION****2.1 BALANCED FLUE UNIT**

Detailed recommendations for flueing are given in BS 5440:1:1978. The following notes are intended to give general guidance.

The boiler must be installed so that the terminal is exposed to the external air. It is important that the position of the terminal allows the free passage of air across it at all times.

The minimum acceptable spacings from the terminal to obstructions and ventilation openings are specified in TERMINAL POSITIONING TABLE.

Where the terminal is within 850mm (34 in) below plastic guttering, an aluminium shield 1.5m (5 ft) long should be fitted to the underside and immediately beneath the guttering.

The air inlet/products outlet duct and the terminal of the boiler must not be closer than 50mm (2 in) to combustible material. Detailed recommendations on protection of combustible material are given in BS 5440:1:1978, sub-clause 20.1.

**2.2 PROTECTING THE TERMINAL**

Where the terminal is less than 2m (6½ ft) above the level of any ground, balcony, flat roof etc., to which any person has access and which adjoins the wall in which the terminal is situated, the terminal must be protected by a guard of durable material.

Guards are available from Tower Flue Components Ltd., telephone Tonbridge 351555, quoting reference 'A' Black, or from Quinnell, Barrett and Quinnell Ltd., 884 Old Kent Road, London S.E.15, quoting reference type 'E'.

2.3 Where the boiler is fitted in a room, the boiler does not require the room containing it to have a permanent air vent.

**2.4 CUPBOARD/COMPARTMENT VENTILATION**

Where the boiler is fitted in a cupboard or compartment, the ventilation area must be in accordance with AIR VENT TABLE.

NOTE: Both the high level and low level air vents must communicate with the same room or must both be on the same wall to outside air.

**3. LOCATION OF PARTS AND CONTENTS OF PACKAGING****PACK 1**

Boiler Chassis:- Main Body of Boiler  
Outer Case:- Main Case Body  
Wall Frame  
Burner  
Casing Surrounds  
Fixing Pack (Screws, Wallplugs etc.)  
User and Installation Instructions.

PACK 2 See Tick Box on Carton for Type.

**Basic Model:-**

Controls Cabinet  
Controls Drawer (Basic)  
Piezo Unit  
Door and Base Assembly (Basic)  
Bag of Fixings

**Programmer Model:-**

Controls Cabinet  
Controls Drawer (Programmer)  
Programmer Body - Battery not supplied.  
Piezo Unit  
Door and Base Assembly (Programmer)  
Bag of Fixings

**PACK 3**

Blanced Flue Terminal. See Note 4.1.

## 4 INSTALLATION

**Note:** On outside brickwork face, clear edge of hole on top and bottom faces for the brackets on the wall sleeve.

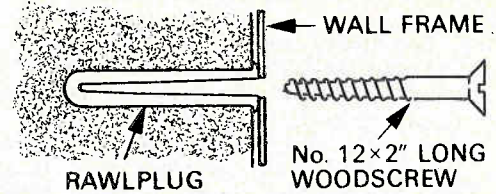
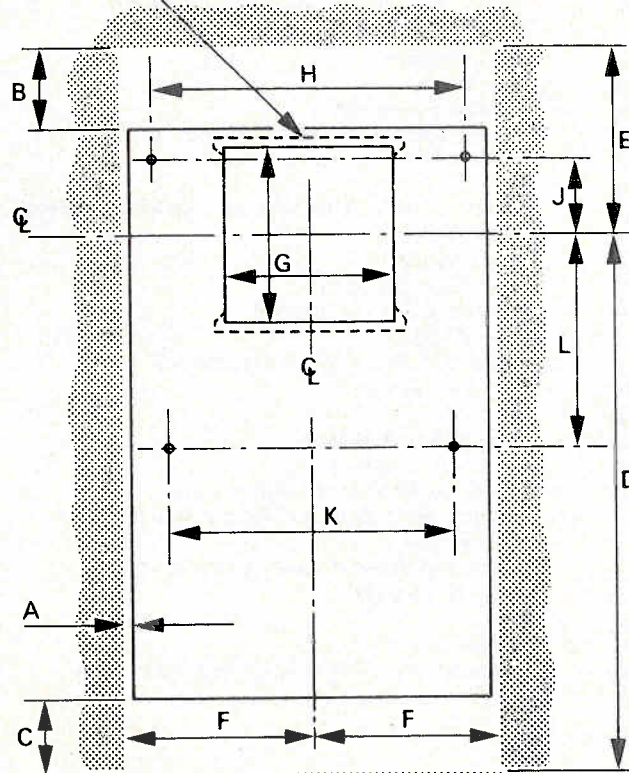

**Recommended Minimum Clearances from Walls, Ceiling, Floor, Cupboards, Worktops, etc.**

|   |                              |     |                   |
|---|------------------------------|-----|-------------------|
| A | L.H. and R.H. side of casing | 6   | $\frac{1}{4}$     |
| B | Top of casing                | 108 | $4\frac{1}{4}$    |
| C | Bottom of casing             | 100 | 4                 |
| D | ☉ to floor—for low fixing    | 709 | $25\frac{15}{16}$ |
| E | ☉ to ceiling—for high fixing | 251 | $9\frac{7}{8}$    |
| F | ☉ to L.H. and R.H. wall face | 246 | $9\frac{1}{16}$   |

|   |                               |            |                       |
|---|-------------------------------|------------|-----------------------|
| G | Balanced flue opening in wall | 250 Square | $9\frac{3}{8}$ Square |
| H | Top fixing holes—centres      | 410        | $16\frac{1}{8}$       |
| J | Top fixing holes to ☉         | 99         | $3\frac{7}{8}$        |
| K | Bottom fixing holes—centres   | 370        | $14\frac{1}{2}$       |
| L | Bottom fixing holes to ☉      | 280        | 11                    |

**Diagram 3**

### 4. INSTALLATION

4.1 Check that the balanced flue unit supplied is suitable for the wall thickness where the boiler is to be fitted, see diagram 2. The standard terminal supplied suits 238mm to 330mm ( $9\frac{3}{8}$  - 13 in). A short terminal to suit 146mm to 238mm ( $5\frac{3}{4}$  -  $9\frac{3}{8}$  in) and extension sleeves to suit 330mm to 578mm (13 in -  $22\frac{3}{4}$  in) are available to special order. When fitting extension sleeves, it will be necessary to flatten lip 'G' on outer wall sleeve 'A' (see diagram 8) into line with the box, to allow the outer extension sleeve to fit over it.

4.2 Remove packaging to reveal outer white casing. Unscrew the two top casing fixing screws and put the casing in a safe place. Remove the two wall frame fixing screws to allow the frame to disengage from chassis of boiler. Turn the appliance over on its front, ready for piping up.

4.3 Mark out the wall surface with the positions for the flue duct and wall frame fixing screw holes as shown in diagram 3. Cut out the hole for the flue duct and drill holes to suit No.12 aluminium Rawlplugs at the fixing screw positions.

4.4 Fix the wall frame to the inner surface of the wall, using the No.12 aluminium Rawlplugs and wood screws supplied.

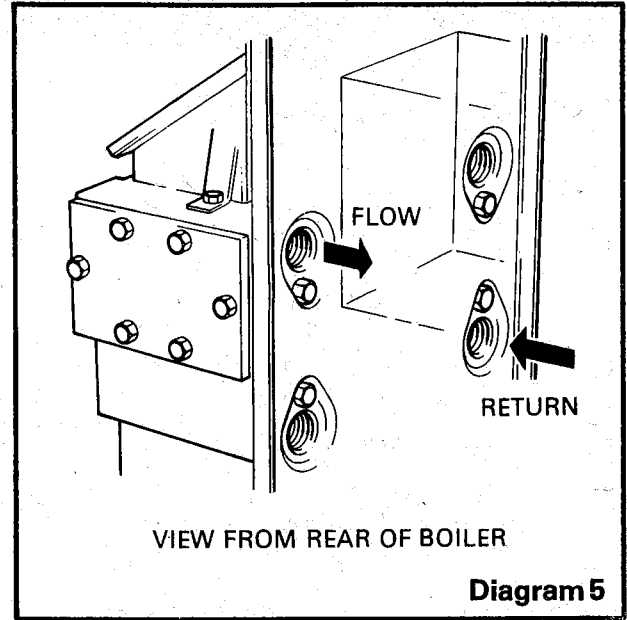
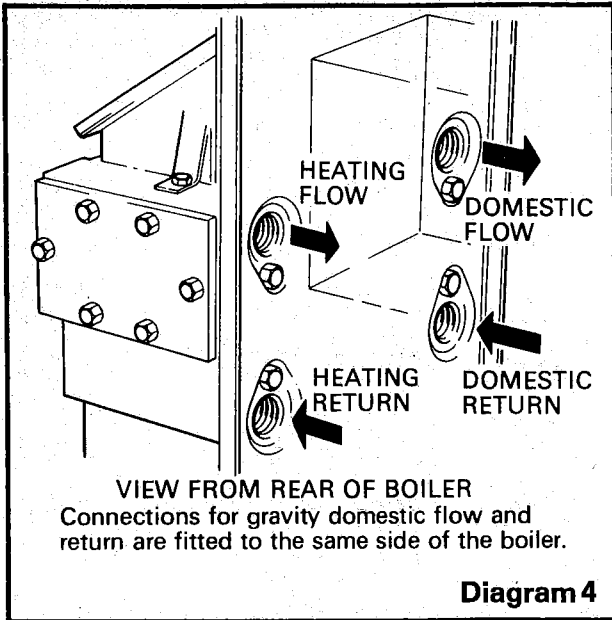

**4.5 WATER CONNECTIONS** (use only taper threaded fittings).

**4.5.1 Gravity domestic hot water.**

It is important that the arrangement illustrated in diagram 4 is adopted when the gravity domestic hot water connections are being prepared. The domestic return pipe must be on the same side as the domestic flow.

The heating flow and return pipes are taken from the other side of the boiler. It is recommended that a cylinder thermostat is used to prevent the stored water temperature becoming unnecessarily high when the central heating pump is off. The domestic flow and return pipes must be 28mm. diameter. The installation must comply with the requirements of BS 5449: Part 1.

If the above conditions cannot be accommodated, it is suggested that pumped primaries be employed.

**4.5.2 Pumped heating and hot water.**

Where single flow and return is taken from the boiler, a minimum static head of 1 metre must be provided between the bottom of the cold feed tank and centre of waterway.

It is important that all connections are made as illustrated in diagram 5. The connections may be fitted on opposite side to that shown, but always in the same relative positions.

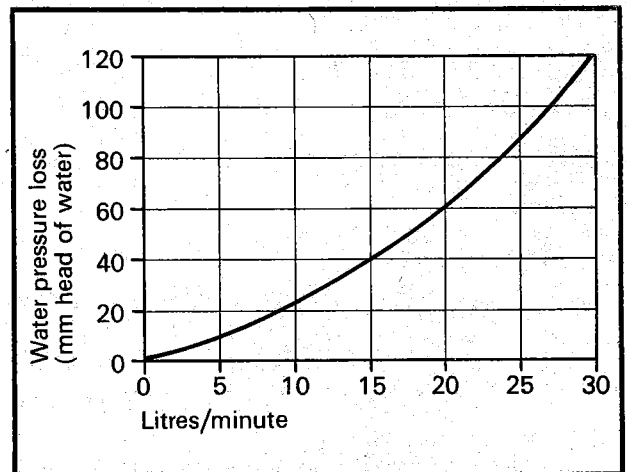

**4.5.3** For all systems supplying domestic hot water the cylinder must be indirect.

## 4 INSTALLATION

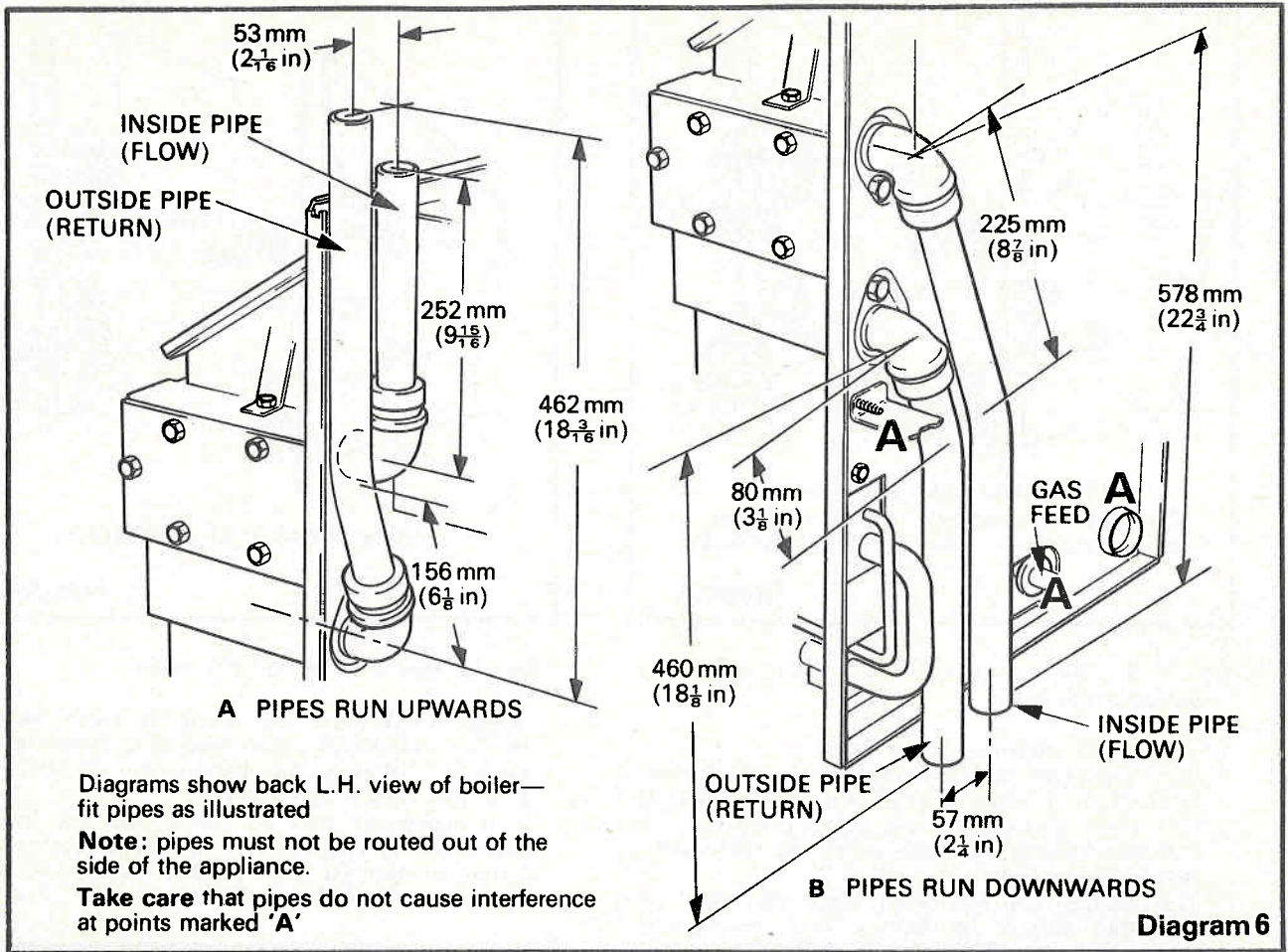

4.5.4 Fit the appropriate elbows into the boiler tappings as required, see diagram 4 and 5. Fit the water pipes to terminate above the top edge of the main panel or below the bottom edge, with the pipe ends as shown in diagram 6. i.e. one higher than the other.

### 4.6 INSTALLATION REMINDERS

#### SAFETY VALVE

Where a safety valve is fitted it should be adjacent to the boiler on the flow pipe. It must not be possible to isolate the safety valve from the boiler by means of any intermediate cock. For further details see BS 5376:2:1976 (12.2).

#### DRAIN-OFF COCK

A drain-off cock must be fitted to the lowest part of the system for complete drainage for subsequent servicing.

4.7 Offer the boiler to the wall frame squarely and vertically and position the turnover at the top of the main panel over the 5.5mm deep register on the wall frame, see diagram 7. Secure the boiler to the wall frame with the two No.12 x  $\frac{3}{4}$  in. long self-tapping pan hd. screws and plain washers supplied, in the position shown in diagram 7.

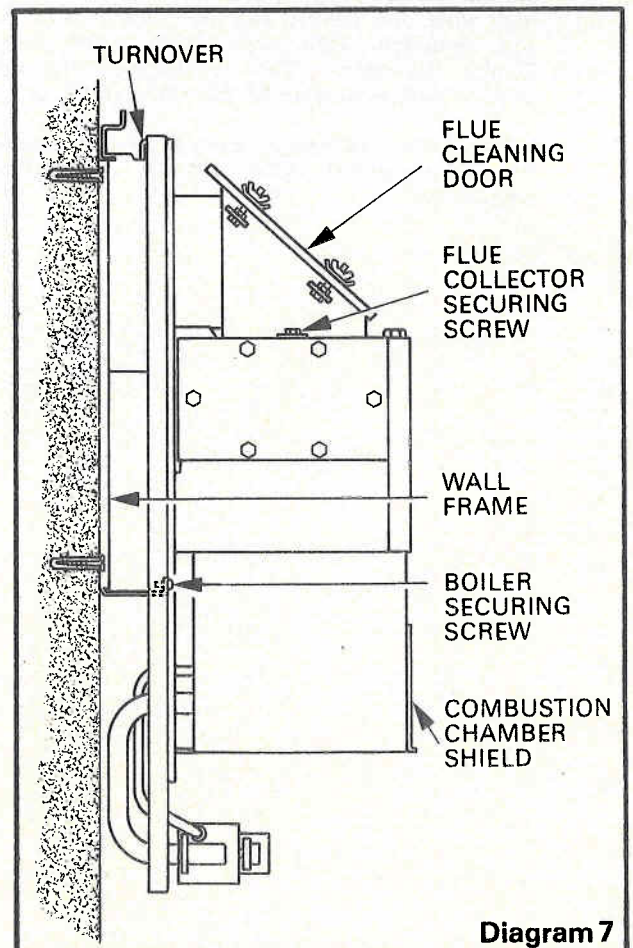

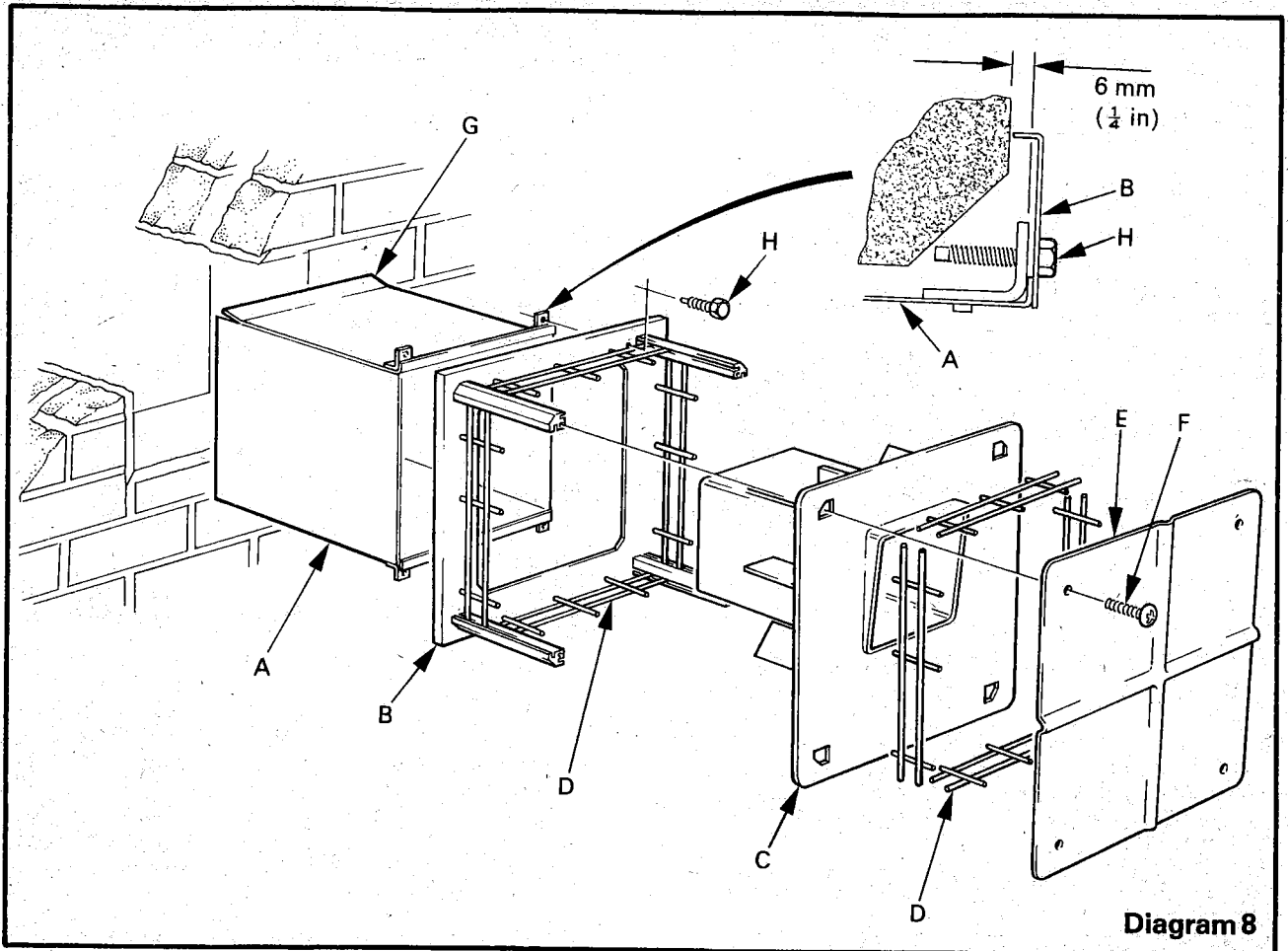

Diagram 8

4.8 Take the outer section of the balanced flue, see diagram 8, and remove the four screws 'F'. This releases the outer baffle 'E'. Remove the four wire guards 'D' from the slots in the spacers and then pull off the inner baffle and sleeve assembly 'C'.

4.9 Place the outer wall sleeve 'A' centrally into the prepared hole in the wall from outside, engaging it over the outer flue duct on the boiler. It may be necessary to chase away the outer wall surface locally to the top and bottom fixing angles on the outer wall sleeve, see diagram 3, to allow the terminal frame to be flush with the wall. Cement the wall sleeve in position, ensuring that the brackets are clear of cement and stand 6mm (1/4 in) proud of the wall surface, see diagram 8.

4.10 Seal between the wall sleeve and outer flue duct with the sealant strip provided.

4.11 The terminal frame 'B', with the aluminium spacers and inner wire guards still in position, can now be secured to the brackets on the wall sleeve with the four 1/4 in. BSW x 1 in. thread hex. hd. dogpoint screws 'H' provided. Note that the terminal frame is fitted with the face marked 'TOP' uppermost.

4.12 Re-fit the parts removed in 4.8, again making sure that the face of Inner baffle 'C' marked 'TOP' is uppermost. Seal between the inner sleeves with the sealant strip provided, before re-fitting outer baffle.

4.13 Complete the water connections to the pipes previously fitted, using compression fittings.

4.14 Make the gas connection to the Rc 1/2 union gas cock in the controls area of the boiler.

4.15 Remove the combustion chamber shield from the packing

4.16 Remove the burner from the packing and fit as follows:-

4.16.1 Offer burner into combustion chamber inclined backward and upward at the locating pin end to clear the pilot bracket.

4.16.2 Fit the hole in the venturi strap at R.H. end over the injector.

4.16.3 Lower the locating pin into the plunged hole in the pilot bracket, ensuring that it is seated correctly.

4.17 Fit combustion chamber shield.

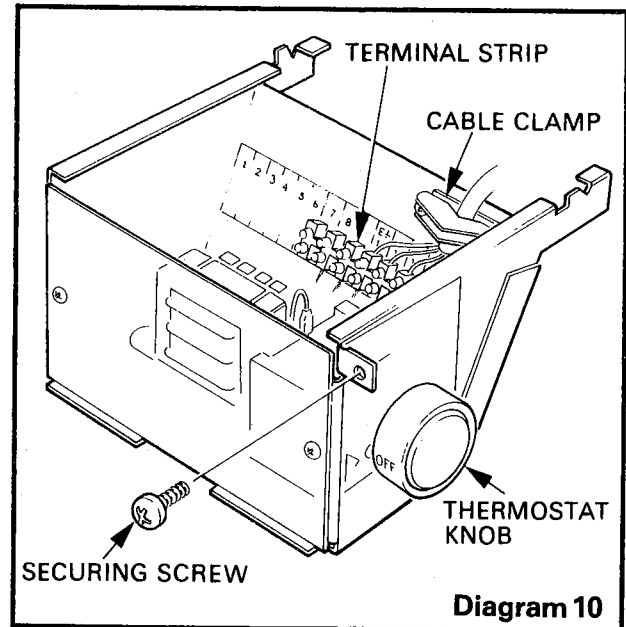
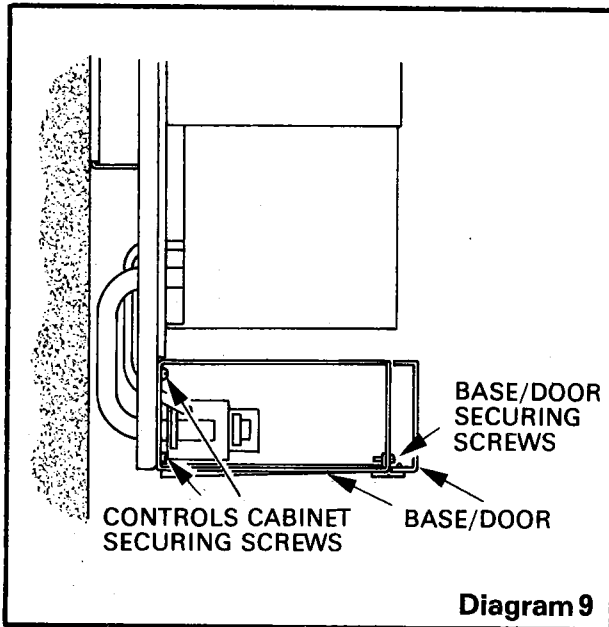

## 5. CONTROLS PACK - BASIC & PROGRAMMER MODELS

5.1 Open the controls pack - see section 3 for list of contents. Remove the screws securing the base/door assembly of the controls cabinet, see diagram 9, remove the assembly and put in a safe place.

Remove the screw securing the controls drawer to the controls cabinet and completely remove the controls drawer. See diagram 10 and 13.

5.1.2 Screw the controls cabinet to the bottom of the main panel using the four screws provided, see diagram 9. Connect the loose end of the ignition lead to the Piezo Unit at the L.H. side of the controls cabinet.

5.2 Remove the L.H. gland plates, marked 'R' in diagram 19.

5.2.1 Supporting the controls drawer, feed the thermostat phial through the large grommet in the bottom L.H. side of the main panel and through the gland plate aperture. Engage the controls drawer on to its slides in the underside of the controls cabinet sufficiently to support the drawer. Fit the phial into the phial pocket and retain with the fixing provided.

5.2.2 Ensure that there is clearance between the thermostat capillary and the boiler.

5.2.3 Replace the L.H. Gland plates.

## 6. WIRING INSTRUCTIONS FOR BASIC CONTROL DRAWER

THE INSTALLER IS REQUESTED TO ADVISE THE USER OF THE CONTROLS SCHEME USED WITH THIS BOILER AND TO GIVE GUIDANCE ON THE OPERATION OF THE CONTROLS.

These diagrams are schematic and for information only. The installation must comply with I.E.E. regulations and all cable and connections must be of the approved type.

6.1 Feed the mains cable from the rear, through the large grommet in the bottom L.H. side of the main panel.

6.2 Pass the mains cable over the rear lip of the controls drawer and through the cable clamp. Connect the three wires to the appropriate terminals in the terminal block and tighten the screws in the cable clamp, ensuring that the earth wire is made longer than the line and neutral

6.3 In the event of an electrical fault after installation of the appliance, preliminary system checks must be carried out (i.e. earth, continuity, polarity and resistance to earth as described in the British Gas Multimeter Instruction Book.)

6.4 Push the controls drawer fully home and secure with the screw previously removed.

6.5 Pass the orange gas valve lead through the large grommet in the main panel, across the back of the panel and in through the aperture at the R.H. side of the valve. Connect to the gas valve.

6.6 Refit door/base assembly - a reverse procedure of 5.1.

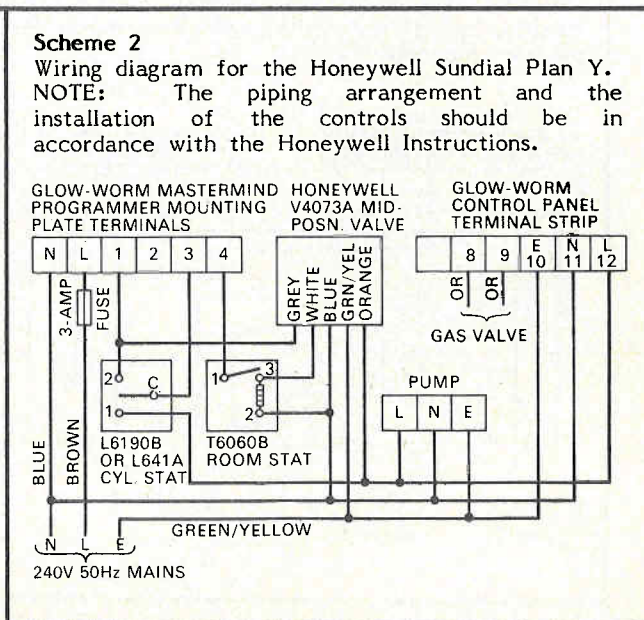
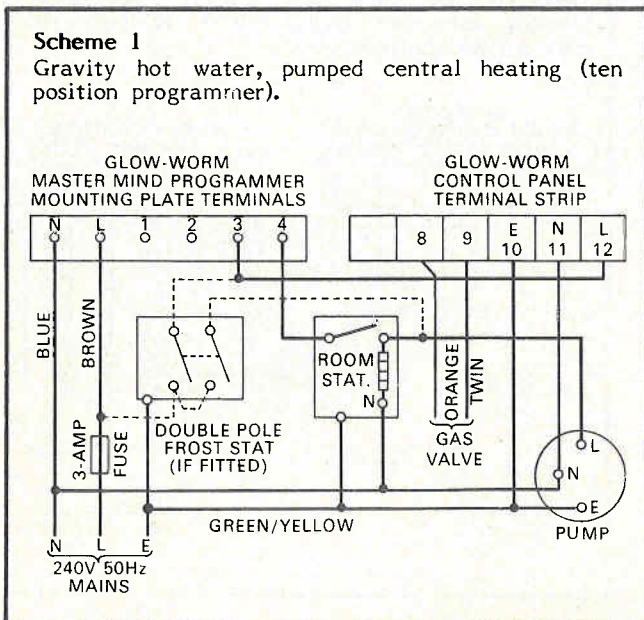
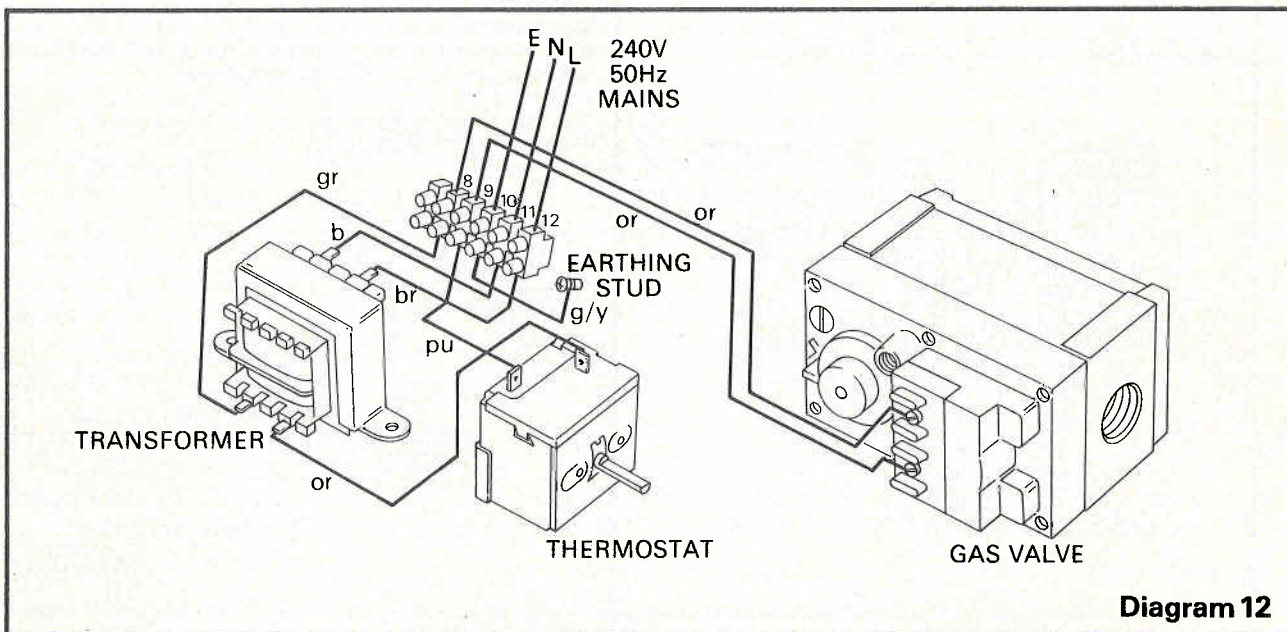
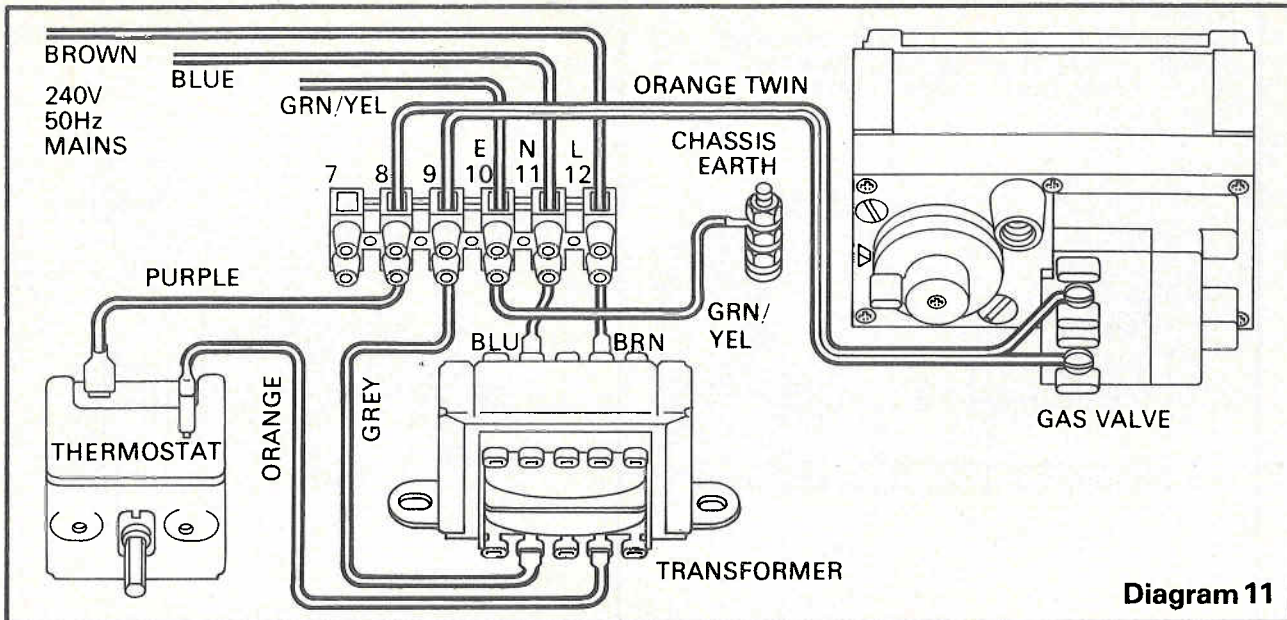

# 6 CONTROLS PACK – BASIC MODEL

## Scheme 3

Independent control of domestic hot water and central heating, both pumped, using two spring return motorised valves (sixteen position programmer).

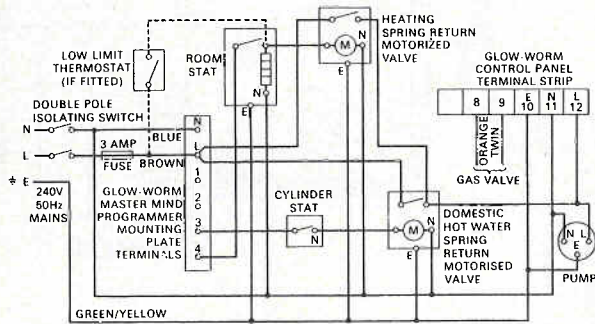

## Scheme 4

Domestic hot water and central heating, both pumped, using a Drayton Flow-share valve.

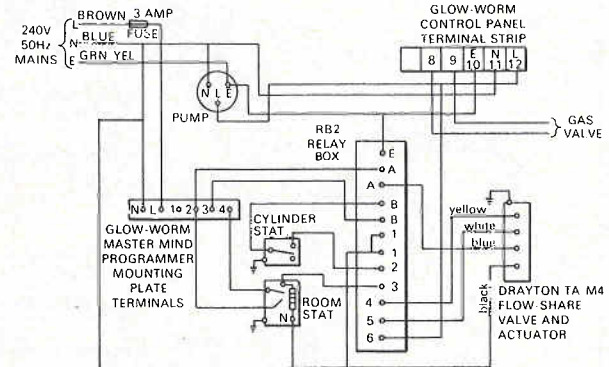

## Scheme 5

Wiring diagram for the Satchwell Duoflow system, using the sixteen position programmer.

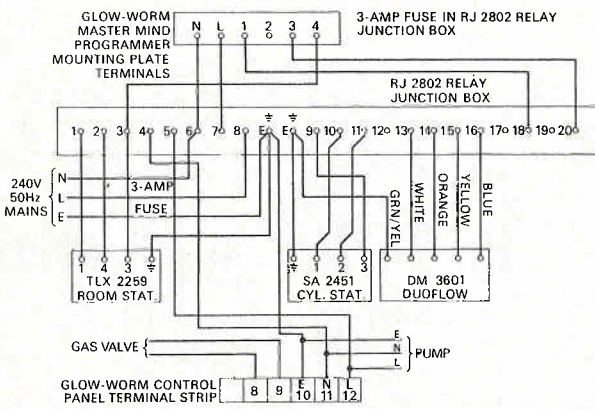

## Scheme 6

Independent control of domestic hot water and central heating, both pumped, using two motorised valves (sixteen position programmer).

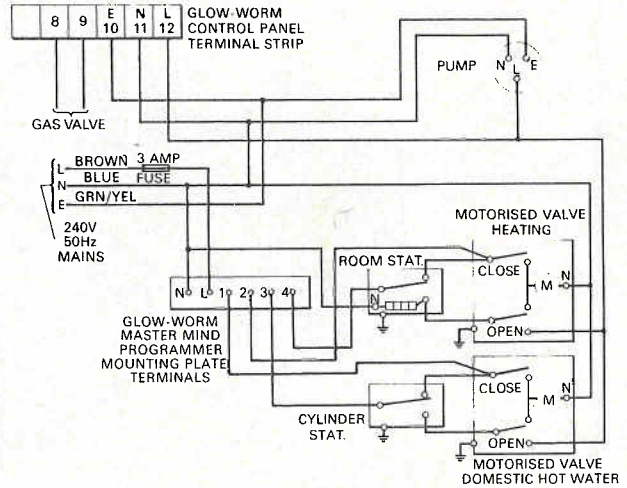

## Scheme 7

Domestic hot water and central heating, both pumped, using one fully motorised valve (ten position programmer).

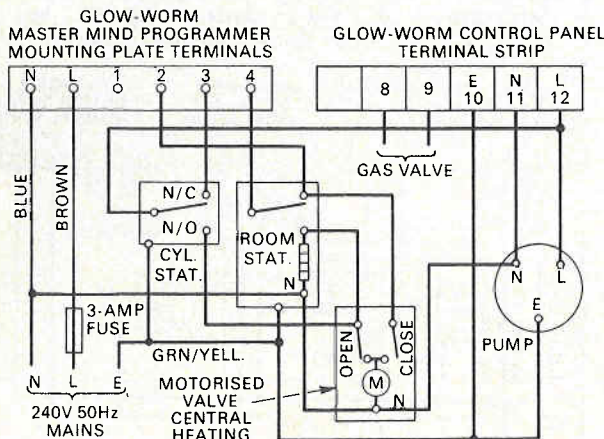

## Scheme 8

Domestic hot water and central heating, both pumped, using one spring return motorised valve (ten position programmer).

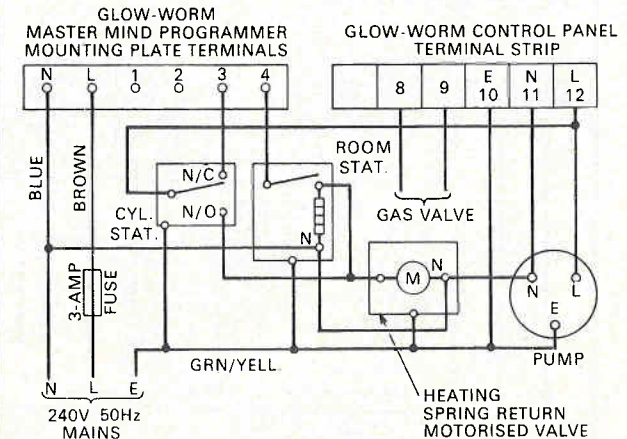

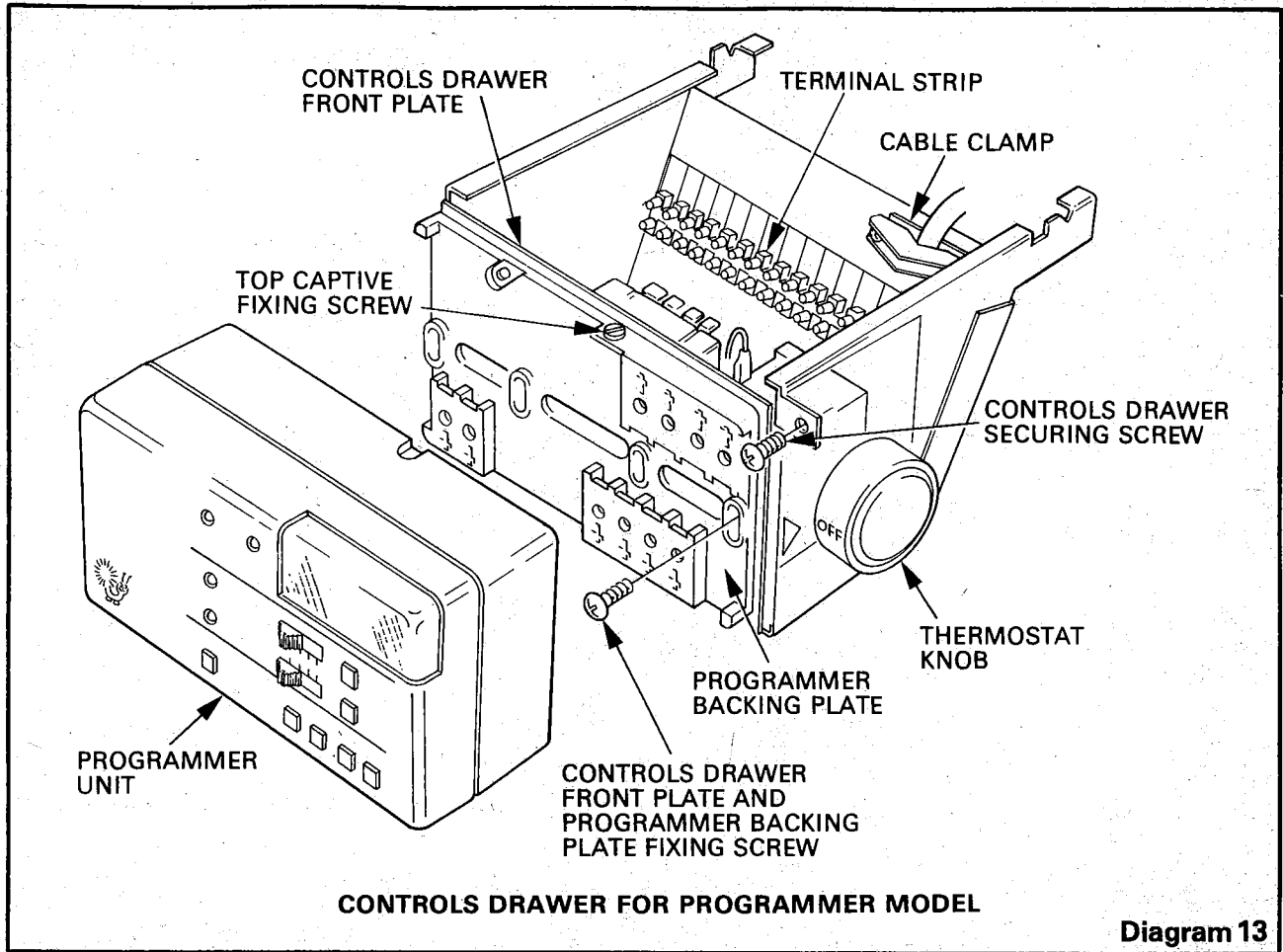

**7. WIRING INSTRUCTIONS FOR PROGRAMMER CONTROL DRAWER**

THE INSTALLER IS REQUESTED TO ADVISE THE USER OF THE CONTROLS SCHEME USED WITH THIS BOILER AND TO GIVE GUIDANCE ON THE OPERATION OF THE CONTROLS.

These diagrams are schematic and for information only. The installation must comply with I.E.E. Regulations and all cable and connectors must be of the approved type.

- 7.1 Feed the mains cable from the rear, through the large grommet in the bottom L.H. side of the main panel.
- 7.2 Pass the mains cable over the rear lip of the controls drawer and through the cable clamp. Connect the three wires to the appropriate terminals in the terminal block and tighten the screws in the cable clamp, ensuring that the earth wire is made longer than the line and neutral.
- 7.3 Unpack the programmer body.
- 7.4 Push the programmer body on to its backing plate, ensuring that the electrical connections are aligned.
- 7.5 Tighten the top and bottom captive fixing screws, see diagram 13.
- 7.6 In the event of an electrical fault after installation of the appliance, preliminary system checks must be carried out (i.e. earth, continuity, polarity and resistance to earth as described in the British Gas Multimeter Instruction Book.)

7.7 Push the controls drawer fully home and secure with the screw previously removed.

7.8 Pass the orange gas valve lead through the large grommet in the main panel, across the back of the panel and in through the aperture at the R.H. side of the valve. Connect to the gas valve.

7.9 Refit door/base assembly - a reverse procedure of 5.1.

**7.10 PROGRAMMER ALIGNMENT**

7.10.1 When the unit is finally assembled the programmer facia should appear central to the aperture in the front door.

7.10.2 If adjustment is required, remove the programmer body. Loosen the two programmer backing plate fixing screws, and the backing plate can now be moved to the position required. Retighten screws.

7.10.3 Replace programmer body.

**7 CONTROLS PACK – PROGRAMMER MODEL**

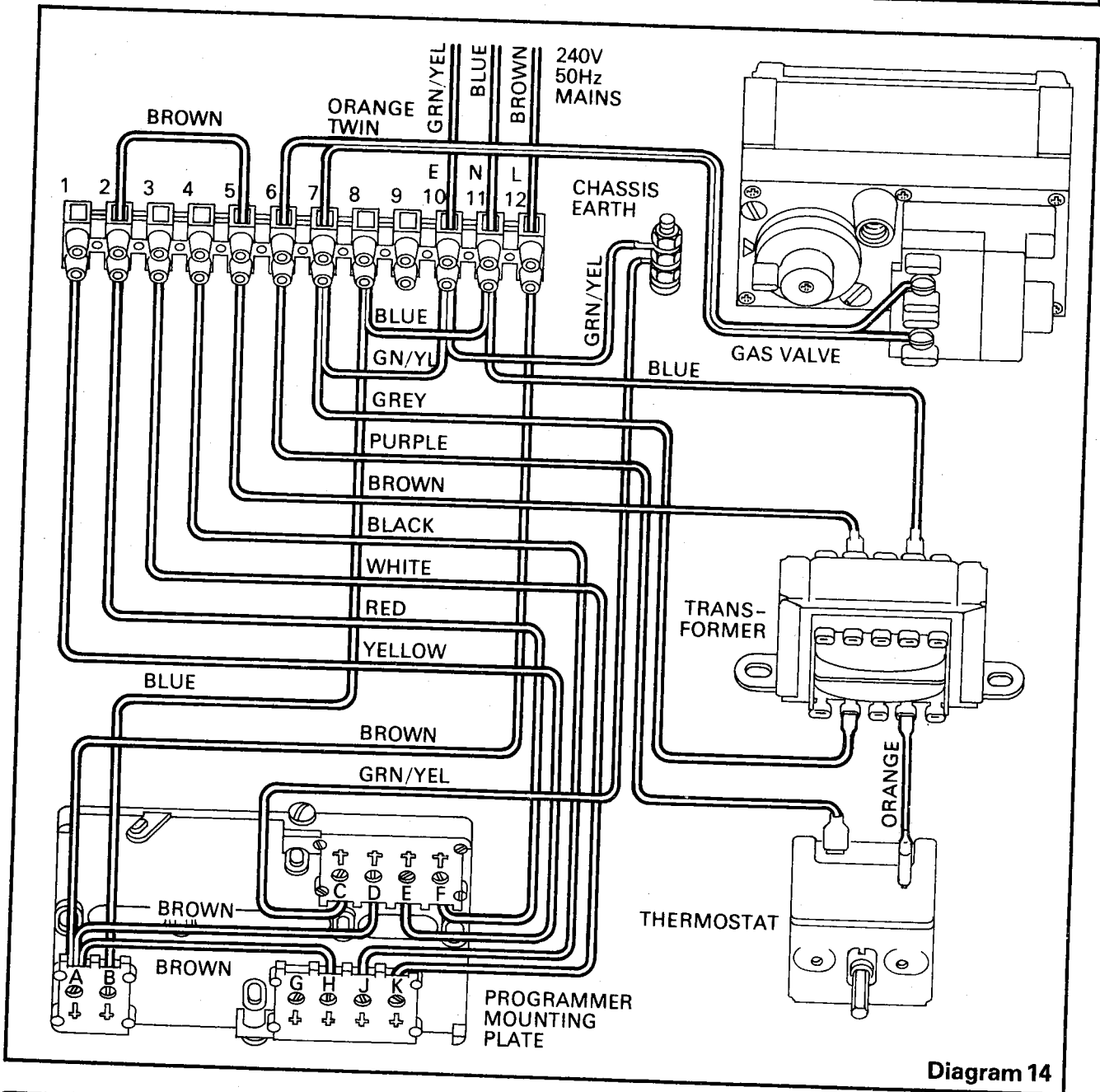

**Diagram 14**

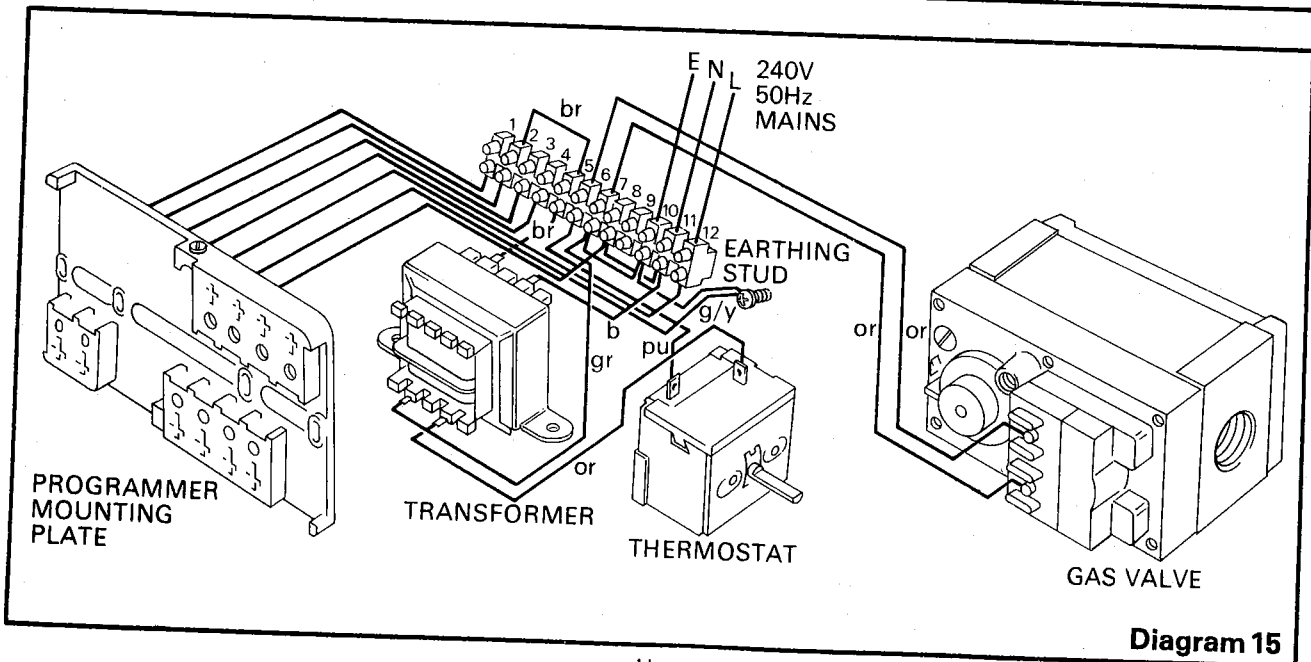

**Diagram 15**

**Scheme 9**

Pumped central heating with gravity hot water circulation (ten position programmer).  
If a room thermostat is not fitted, link terminals 4 and 9.

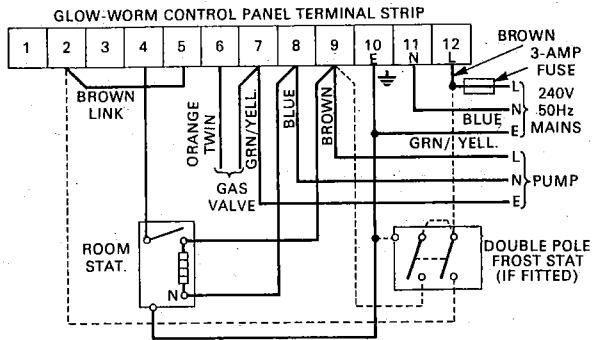

**Scheme 10**

Independent control of central heating and domestic hot water, both pumped, using two motorised valves (sixteen position programmer).  
Remove brown link between terminals 2 and 5, and wire external controls and mains as shown in diagram.

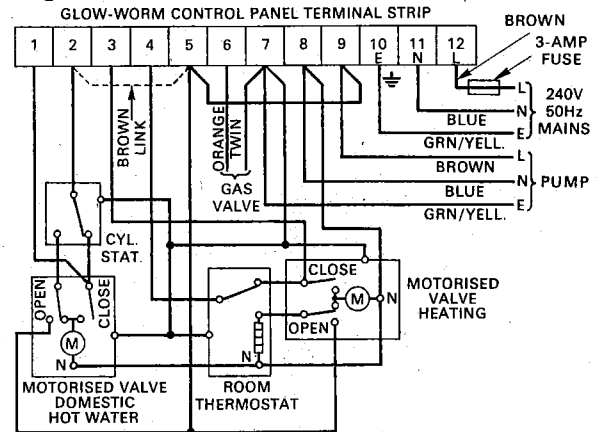

**Scheme 11**

Pumped central heating circuit with gravity hot water circulation (sixteen position programmer), giving independent temperature control of domestic hot water.  
Remove brown link between terminals 2 and 5, and wire external controls and mains as shown in diagram.

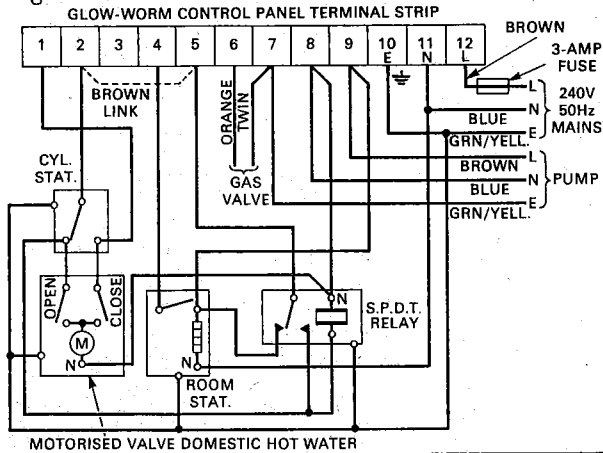

**Scheme 12**

Wiring diagram for fitting the Satchwell Duoflow system, using the sixteen position programmer.  
Remove brown link between terminals 2 and 5, and wire external controls and mains as shown in diagram.

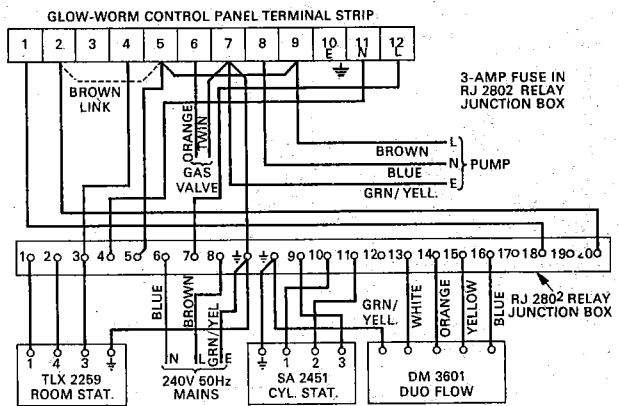

**Scheme 13**

Central heating and domestic hot water, both pumped, using a Drayton Flow-share valve (sixteen position programmer).  
Remove brown link between terminals 2 and 5, and wire external controls and mains as shown in diagram.

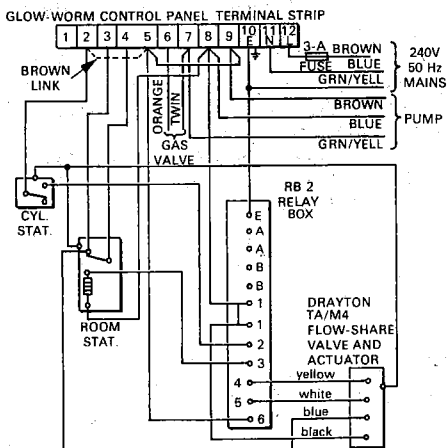

**Scheme 14**

Independent control of domestic hot water and central heating, both pumped, using two spring return motorised valves (sixteen position programmer).  
Remove brown link between terminals 2 and 5, and wire external controls and mains as shown in diagram.

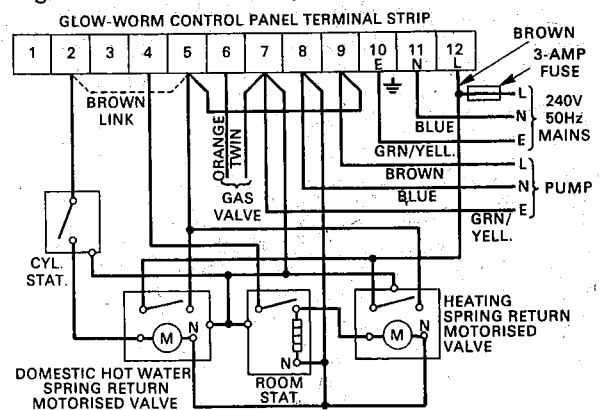

## 8 PROGRAMMER OPERATION

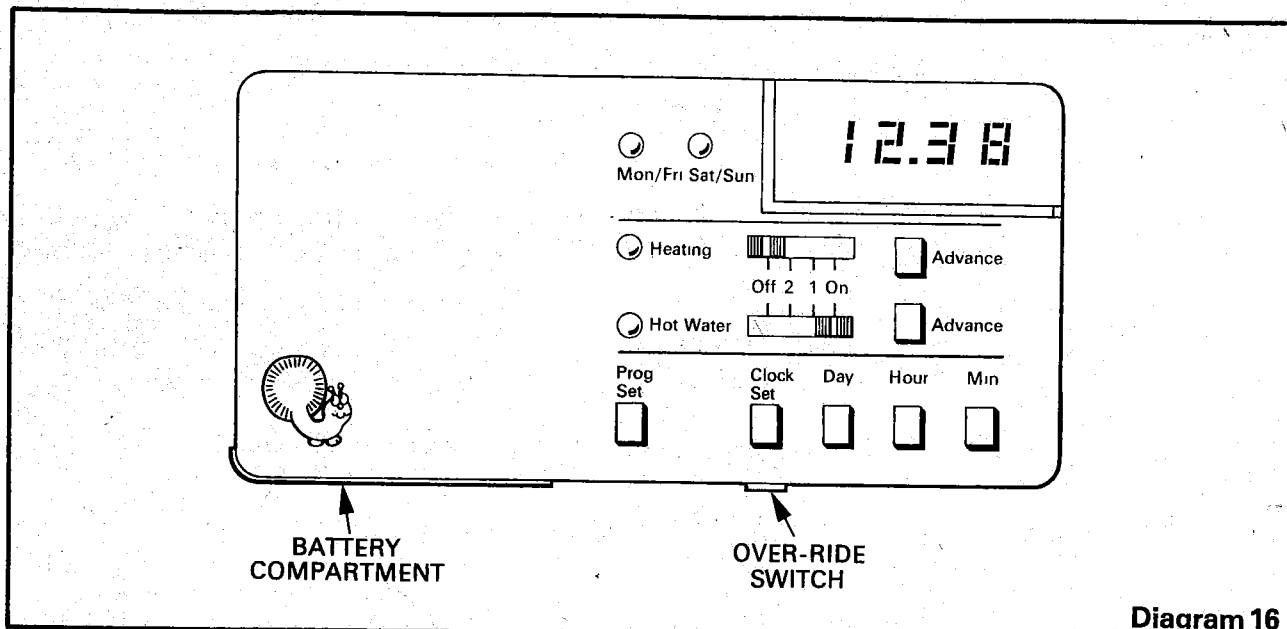

Diagram 16

### 8. PROGRAMMER - SETTING INSTRUCTIONS (See Diagram 16)

#### 8.1 SETTING TIME OF DAY AND DAY OF WEEK

8.1.1 Press and hold "CLOCK SET" button whilst carrying out steps 8.1.2, 8.1.3 and 8.1.4.

8.1.2 Day set; Keep pressing and releasing "DAY" button until display shows correct day number ie. 1 = Monday 2 = Tuesday 3 = Wednesday and so on.

8.1.3 Time set: Press and hold "HOUR" button. One or two digits will now appear on display and after a short interval will start to advance. Continue holding "HOUR" button until hour shown on display is close to actual hour of day, then release.

Each single press of "HOUR" button will advance display one hour. Continue until actual hour of day is shown on display.

8.1.4 Repeat step 8.1.3 above using "MIN" button until correct minute of day is reached. "CLOCK SET" button may now be released; clock starts and seconds point begins to flash, immediately "CLOCK SET" button is released.

#### 8.2 SETTING REQUIRED PROGRAMMES

The Programmer provides two separate timed periods for each weekday and two different timed periods for weekends. Weekday and weekend timed periods for each service (Heating or Hot Water) are entered separately and may be different from each other.

#### 8.3 SETTING TIMED PERIODS

8.3.1 Press and release "PROG. SET" button. Display will show the words "ON 1" and the "MON/FRI" indicator and "HEATING" indicator will be illuminated. After approximately 6 seconds the display will go blank. You should now enter using the "HOUR" and "MIN" buttons, the time you require the central heating to come on, on weekdays.

NOTE: If for example, the heating is required to switch on at 6.00 a.m.

After setting, using the "HOUR" button the display will show '6 - -'. It is necessary to use the "MIN" button until the display show '6.00' before the programmer will function correctly.

8.3.2 Press and release "PROG. SET" button. Display will show the words "OFF 1" and the "MON/FRI" indicator and "HEATING" indicator will be illuminated. After 6 seconds the display will go blank, enter time at which you wish the first timed period for central heating, for weekdays to end using the "HOUR" and "MIN" buttons.

8.3.3 Press and release "PROG. SET" button. Display will show the words "ON 2" and the "MON/FRI" indicator and "HEATING" indicator will be illuminated. After 6 seconds the display will go blank; enter time at which you wish the second timed period for central heating, for weekdays to start using the "HOUR" and "MIN" buttons.

8.3.4 Press and release "PROG SET" button. Display will show the words "OFF 2" and the "MON/FRI" indicator and "HEATING" indicator will be illuminated. After 6 seconds the display will go blank; enter time at which you wish the second timed period for central heating, for weekdays to end using the "HOUR" and "MIN" buttons.

Subsequent single presses of the "PROG.SET" button will show displays indicated below. After the 6 second delay following each display when the screen goes blank, the required time should be entered into the programmer using the "HOUR" and "MIN" buttons as previously.

| <u>INDICATOR</u>         | <u>DISPLAY</u> | <u>ACTION (Using "HOUR" and "MIN" buttons)</u>   |
|--------------------------|----------------|--|
| "SAT/SUN"<br>"HEATING"   | ON 1           | Set time required for start of first timed period for central heating, Saturday and Sunday.  |
| "SAT/SUN"<br>"HEATING"   | OFF 1          | Set time required for end of first timed period for central heating, Saturday and Sunday.    |
| "SAT/SUN"<br>"HEATING"   | ON 2           | Set time required for start of second timed period for central heating, Saturday and Sunday. |
| "SAT/SUN"<br>"HEATING"   | OFF 2          | Set time required for end of second timed period for central heating, Saturday and Sunday.   |
| "MON/FRI"<br>"HOT WATER" | ON 1           | Set time required for start of first timed period for hot water, Monday to Friday.           |
| "MON/FRI"<br>"HOT WATER" | OFF 1          | Set time required for end of first timed period for hot water, Monday to Friday.             |
| "MON/FRI"<br>"HOT WATER" | ON 2           | Set time required for start of second timed period for hot water, Monday to Friday.          |
| "MON/FRI"<br>"HOT WATER" | OFF 2          | Set time required for end of second timed period for hot water, Monday to Friday.            |
| "SAT/SUN"<br>"HOT WATER" | ON 1           | Set time required for start of first timed period for hot water, Saturday and Sunday.        |
| "SAT/SUN"<br>"HOT WATER" | OFF 1          | Set time required for end of first timed period for hot water, Saturday and Sunday.          |
| "SAT/SUN"<br>"HOT WATER" | ON 2           | Set time required for start of second timed period for hot water, Saturday and Sunday.       |
| "SAT/SUN"<br>"HOT WATER" | OFF 2          | Set time required for end of second timed period for hot water, Saturday and Sunday.         |

Press "CLOCK SET" button to display time of day.

**8.4 CHECKING TIMES OF PROGRAMMES**

The start or end of any timed period hot water or central heating for weekday or weekend may be checked by pressing and releasing "PROG. SET" button until indicators and display reach point required. For example, if you wish to determine the times for the **start of the second timed period for central heating on Saturday and Sunday** the "PROG. SET" button should be pressed and released until the following sequence was shown on the programmer.

| <u>INDICATOR</u>   | <u>DISPLAY</u> | <u>ACTION</u>  |
|--|----------------|--|
| "SAT/SUN"<br>(Illuminated)<br>"HEATING"<br>(Illuminated) | ON 2           | Releasing button will now show start of timed period required. |

## 8 PROGRAMMER OPERATION

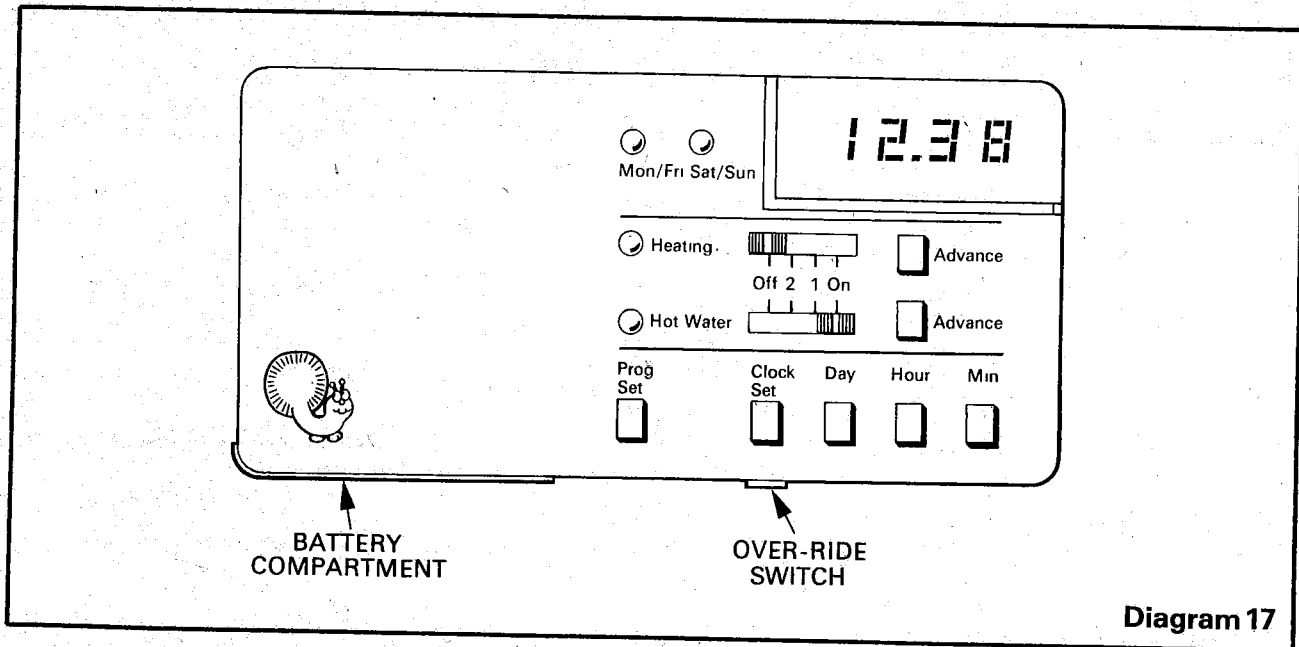

Diagram 17

### 8.5 CHANGING PROGRAMME TIMES

Obtain correct display for the time requiring change, as outlined in step above. "CHECKING TIMES OF PROGRAMMES". Using "HOUR and MIN" buttons change displayed time to that required.

### 8.6 MANUAL OVERRIDE SLIDERS

Separate slider switches are provided for heating and hot water services and each may be independently moved to any of the following positions.

OFF, 2, 1, ON.

Setting to the individual positions gives the following programme.

Off - service is off at all times.

On - service is on at all times irrespective of time set in programmer.

1 - service starts at the time put in for the start of the first timed period and continues to operate until the time put in for the end of the second timed period.

2 - service runs for the two separately timed periods as programmed into the programmer.

### 8.7 ADVANCE BUTTON

Any timed service can be overridden by a single press of the Advance button. For example, should the central heating be on and it is required to switch it off without interrupting the time settings or operating the slide switch, the Advance button is depressed once. The heating indicator will be extinguished and the heating will be off until the start of the next heating period.

### 8.8 BATTERY - This is required to prevent loss of time settings in the event of mains failure.

Ensure that a P P 3 or equivalent battery is fitted in lower left hand compartment of programmer (See 11.10.1 to 11.10.6). The battery should be replaced annually.

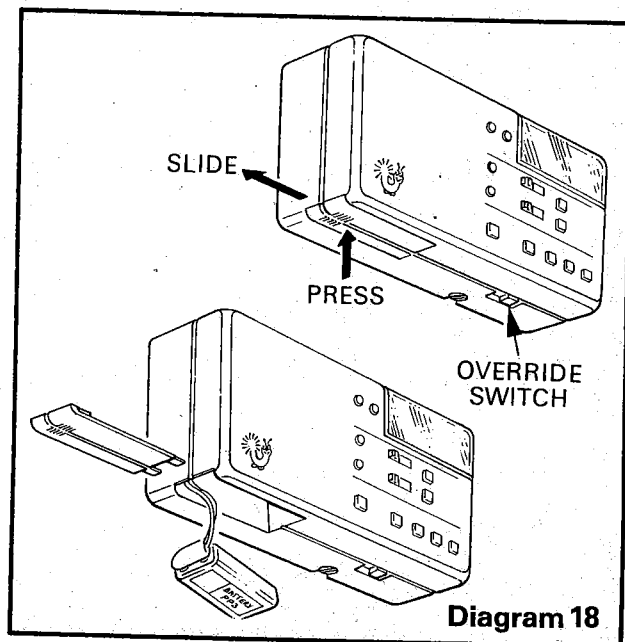
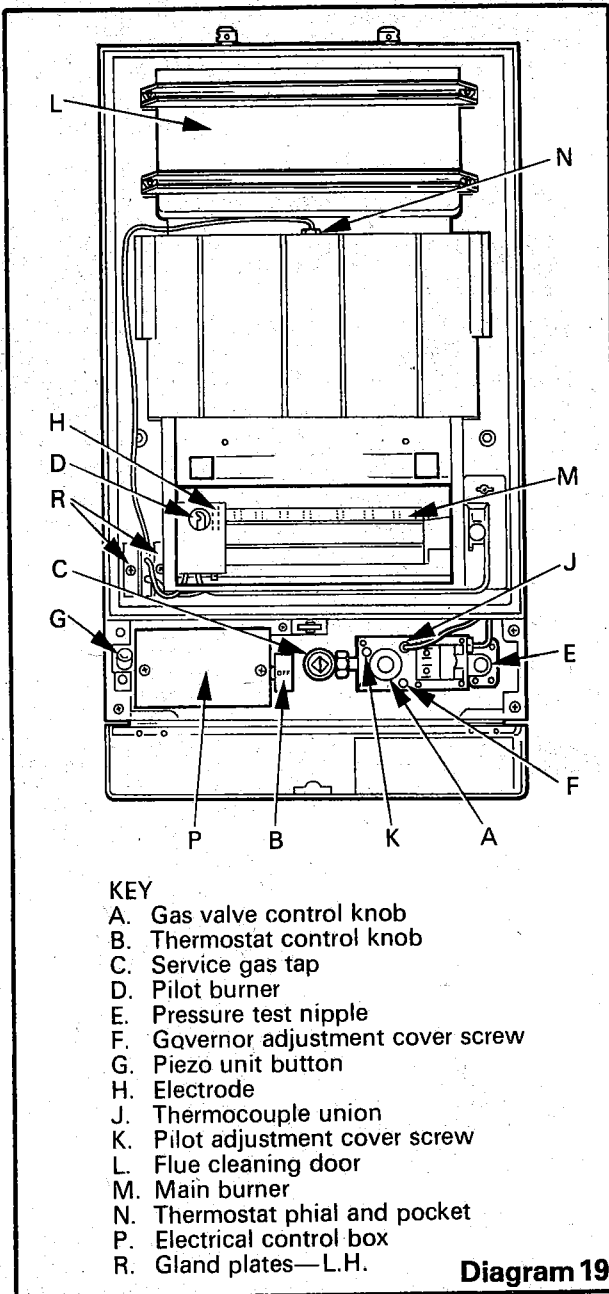

Diagram 18

Note: If the boiler is to be left without power the battery should be removed.

### 8.9 OVER-RIDE SWITCH

In the unlikely event of programmer failure this switch may be used to bypass the programmer (see diagram 18). For normal operation ensure that the switch is in the left hand position.



**9 COMMISSIONING AND TESTING**

**9.1 ELECTRICAL INSTALLATION**

Checks to ensure electrical safety should be carried out by a competent person.

**9.2 GAS INSTALLATION**

The whole of the gas installation should be tested for soundness and purged in accordance with the recommendations of CP 331:3:1974.

**9.3 WATER CIRCULATION SYSTEM**

The whole of the system should be thoroughly flushed out with cold water. Ensure that all valves are open. The system should then be filled with water and air locks cleared. Examine for water soundness.

**9.4 INITIAL LIGHTING, TESTING AND ADJUSTMENT**

**CAUTION:** The following procedure should be carried out by a qualified gas service engineer. The pipes and fittings to the burner will contain an amount of air and it will be necessary to purge the air before the boiler can operate normally.

Identify the boiler controls with relevant details on diagram 19.

9.4.1 Check that the service gas tap 'C' is closed, that is, the indicator line is vertical. See that gas valve control knob 'A' is in the 'OFF' position, ('OFF' opposite red arrow).

9.4.2 See that the mains electricity supply is switched off.

9.4.3 Set thermostat control knob 'B' to the 'OFF' position.

9.4.4 Remove gas pressure test nipple screw 'E' and connect a suitable pressure gauge.

9.4.5 Open service gas tap 'C' and set gas valve control knob 'A' until 'PILOT' setting is opposite the red arrow.

9.4.6 Depress gas valve control knob 'A' fully. Depress and release the piezo unit button 'G' until the pilot burner lights. At this stage, air may be present in the gas pipes and this operation may need to be repeated until all the air has been expelled. When the pilot burner lights keep control knob 'A' fully pushed in for approx. 20 seconds to heat the thermocouple. If the pilot burner fails to light or stay alight, wait **THREE MINUTES** then repeat exactly the above sequence.

The pilot gas rate can be adjusted if necessary as follows:

Remove pilot adjustment cover screw 'K' from gas control and adjust the grub screw beneath it until the pilot burner flame envelopes 10 - 13mm ( $\frac{3}{8}$  -  $\frac{1}{2}$  in) of the thermocouple tip and ignites the main burner smoothly. Turn anti-clockwise to increase pilot flame. Replace cover screw 'K'.

9.4.7 If gas valve control knob 'A' is turned to 'OFF', a safety lock prevents it being turned on again until the thermocouple has cooled to prevent attempted re-light in an unsafe condition. No attempt should be made to force knob 'A' back to pilot position until the three minutes have elapsed.

9.4.8 Make sure that the burner pilot is alight and stable, then turn gas valve control knob 'A' to 'ON' and switch electricity supply on. Set clock or programmer to an 'ON' position and ensure that any other controls are calling for heat. Set thermostat control knob 'B' between 'MIN' and 'MAX' opposite the marker on the control box and the main burner will then light. ('MAX' approx. 82°C, 180°F).

9.4.9 Test for gas leakage around boiler gas components using leak detection fluid.

9.4.10 Set burner gas pressure after ten minutes from lighting (See page 2 for setting pressure). To do this, remove governor adjustment cover screw 'F' and adjust the internal screw to obtain the required pressure. Turn clockwise to increase pressure and anti-clockwise to decrease pressure. Replace the cover screw.

## 9 COMMISSIONING AND TESTING

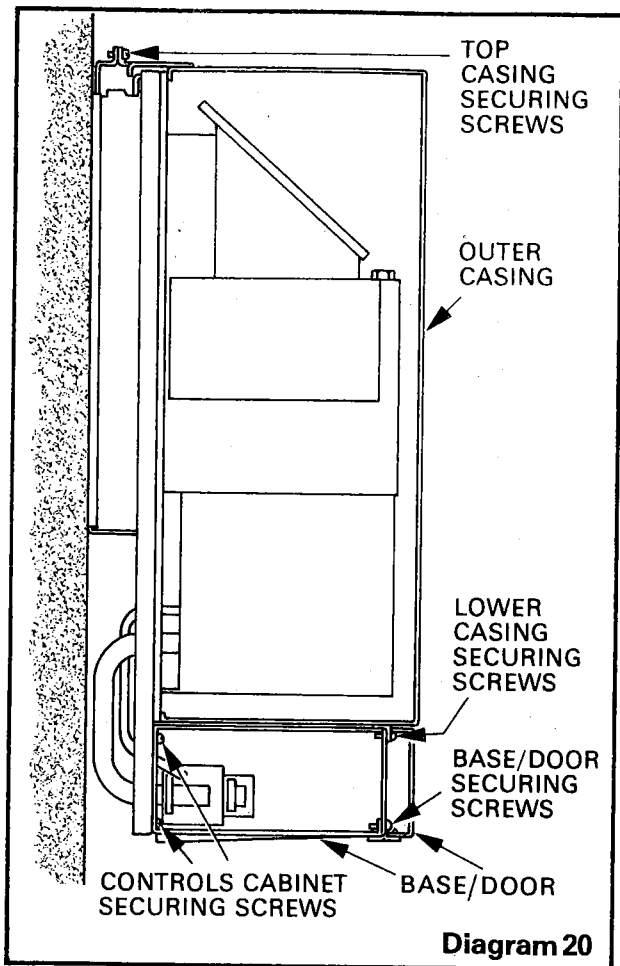

and rapidly drained while still hot to complete the flushing process. The system should again be filled with water and cleared of air locks. Examine for water soundness.

### 9.5 USER'S INSTRUCTIONS

Hand the Users Instructions to the user or purchaser for retention and instruct in the efficient and safe operations of the boiler and heating/hot water system. Advise the user or purchaser that for continued efficient and safe operation of the boiler it is important that adequate servicing is carried out at intervals recommended by the local gas region.

9.4.11 Check operation of the flame failure device as follows. With the main burner alight, turn gas valve control knob 'A' to the 'OFF' position. The knob will then be locked in this position by a safety device in the gas valve. After 60 secs the flame failure device should have closed (a click from the gas valve will indicate its operation). After it has closed it will be possible to re-set knob 'A' back to pilot position. Remove the pressure gauge and re-fit the pressure test nipple screw 'E'. Test for gas leakage around screw.

9.4.12 Check that the boiler thermostat and all automatic controls are operating satisfactorily.

9.4.13 Fit the outer casing by offering up squarely and vertically to the boiler, ensuring that the lower part of the casing clears the pilot tube. Lift approximately 10mm so that the hook section at the top rear of the casing fits over the main panel, see diagram 20 and lower approx. 10mm into position. Secure with the two No.12 x  $\frac{3}{4}$  in. long self-tapping screws at the top and two M5 Pozipan dogpoint screws in the lower position.

9.4.14 Re-light the main burner.

9.4.15 Allow the water system to warm up and then set the pump adjuster to a design position which gives the correct temperature difference of  $11^{\circ}\text{C}$  ( $20^{\circ}\text{F}$ ) between the flow and return pipes. There should be no undue noise in the pipework or emitters and no pumping over of system water at the vent pipe.

9.4.16 Allow the water system to reach maximum working temperature and examine for water soundness. The system should then be turned off

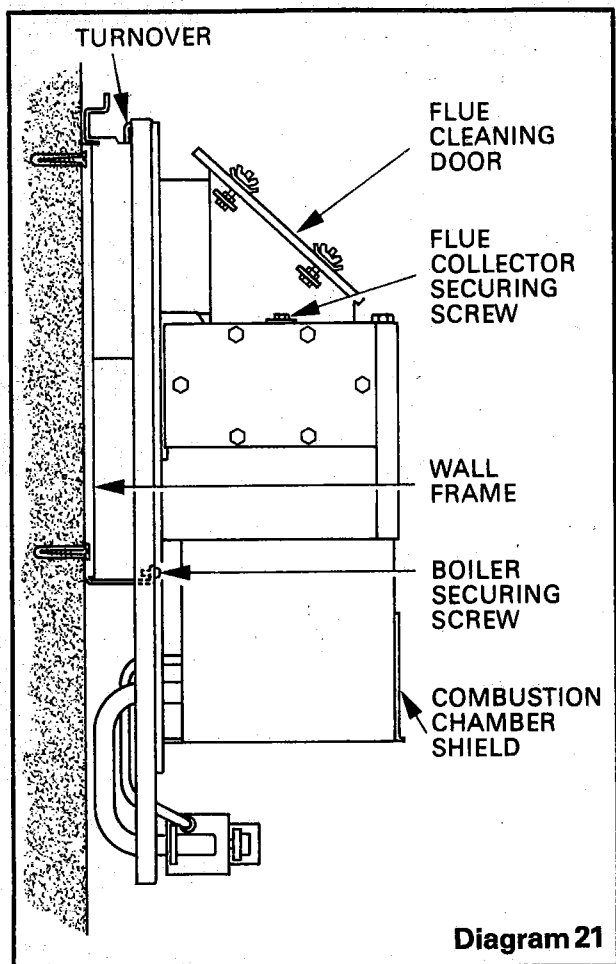

**10 SERVICING**

Servicing must be carried out by a qualified gas service engineer and where appropriate, a qualified electrician. Before commencing a service, turn off the gas supply at the main service cock and isolate the electricity supply.

**10.1 Boiler flueways**

10.1.1 Remove the outer casing by undoing the four screws shown in diagram 20, lift the case approx. 10mm and withdraw.

10.1.2 Remove the combustion chamber shield, see diagram 21, by lifting slightly to clear the lugs and withdraw. Remove the burner by lifting the L.H. end so that the location pin clears its seating, then move to the left so that the R.H. end clears the injector. Withdraw the R.H. end first from the combustion chamber, taking care not to damage the electrode or pilot burner.

10.1.3 Remove the flue cleaning door by releasing the four wing nuts and lifting off.

10.1.4 Place a sheet of paper in the combustion chamber, over the pilot burner, to catch the flue debris.

10.1.5 Clean the boiler flueways and fins thoroughly with a suitable stiff brush.

**10.2 Burner**

With the burner removed as above, clean thoroughly.

## 11 REPLACEMENT OF PARTS

### 11 REPLACEMENT OF PARTS

Before removing or replacing any parts, make sure that the gas supply is turned off and the electricity supply is switched off.

NOTE: For items 11.1 to 11.5 remove outer casing and burner as in 10.1.1 and 10.1.2. For items 11.6 to 11.8 remove outer casing as in 10.1.1. For items 11.1 to 11.8 remove controls cabinet base/door assembly by removing the two securing screws, see diagram 20

All items are replaced in reverse order, except where noted.

#### 11.1 Gas Valve

Disconnect the orange electrical leads, thermocouple and pilot tube connections at the gas valve.

Undo the union nut at the gas cock at L.H. side of the gas valve.

Undo the four screws securing the gas valve flange fitting to the gas manifold at R.H. side of the gas valve. Take care not to damage the gasket between the flanges, should any damage occur then a new gasket, Item No. 2 on the list of replacement parts must be fitted. The gas valve is now free and can be removed.

When screwing the flange fitting and union fitting into the replacement valve, use a little jointing compound on the threads to ensure a gas-tight seal. Remove the screws and spacers from the old valve and fit to the replacement. Re-assemble in reverse order to that described, carefully re-fitting the gasket between the flanges. Do not tighten thermocouple union 'J' more than one quarter turn beyond finger tight. It will be necessary to purge the system of air after changing the gas valve and re-lighting should be carried out as in 9.4 INITIAL LIGHTING AND ADJUSTMENT.

#### 11.2 Injector

When the burner is removed, the injector can be seen at the R.H. side of the combustion chamber. It can be unscrewed and replaced as necessary. When replacing, use a little jointing compound on the threads to ensure gas soundness.

#### 11.3 Pilot burner

11.3.1 Remove the front pilot shield by unscrewing the screw and nut securing it to the combustion chamber side (See diagram 22). Pull out the clip holding the thermocouple into the pilot burner and pull the thermocouple downwards out of the pilot burner.

11.3.2 Disconnect the lead from the electrode and remove the hex. nut from the stud securing the electrode to the pilot bracket then remove the electrode. Disconnect the pilot union at the base of the burner using two spanners, one on the union nut and the other on the hexagon immediately above the union nut and thread. Slacken the hex. nut securing the pilot burner at the L.H. side. The pilot burner can now be removed.

#### 11.4 Thermocouple

11.4.1 Remove front pilot shield as in 11.3.1. The thermocouple can then be removed after releasing the clip securing it to the pilot and pulling it downward.

11.4.2 Disconnect from the gas valve by unscrewing union 'J' and remove the two gland plates 'R' on the boiler back plate, (see diagram 19). The thermocouple can now be withdrawn.

11.4.3 To re-fit the thermocouple, feed the gas valve end downwards through the cut-out in the combustion chamber base, then via the gland plate aperture, down the back of the main panel, to come through the aperture at the R.H. side of the gas valve and connect at union 'J'. Do not tighten this more than one quarter turn beyond finger tight.

11.4.4 Connect the other end of the thermocouple to the pilot burner and secure with the clip. Re-fit the gland plates, ensuring that a good seal is made.

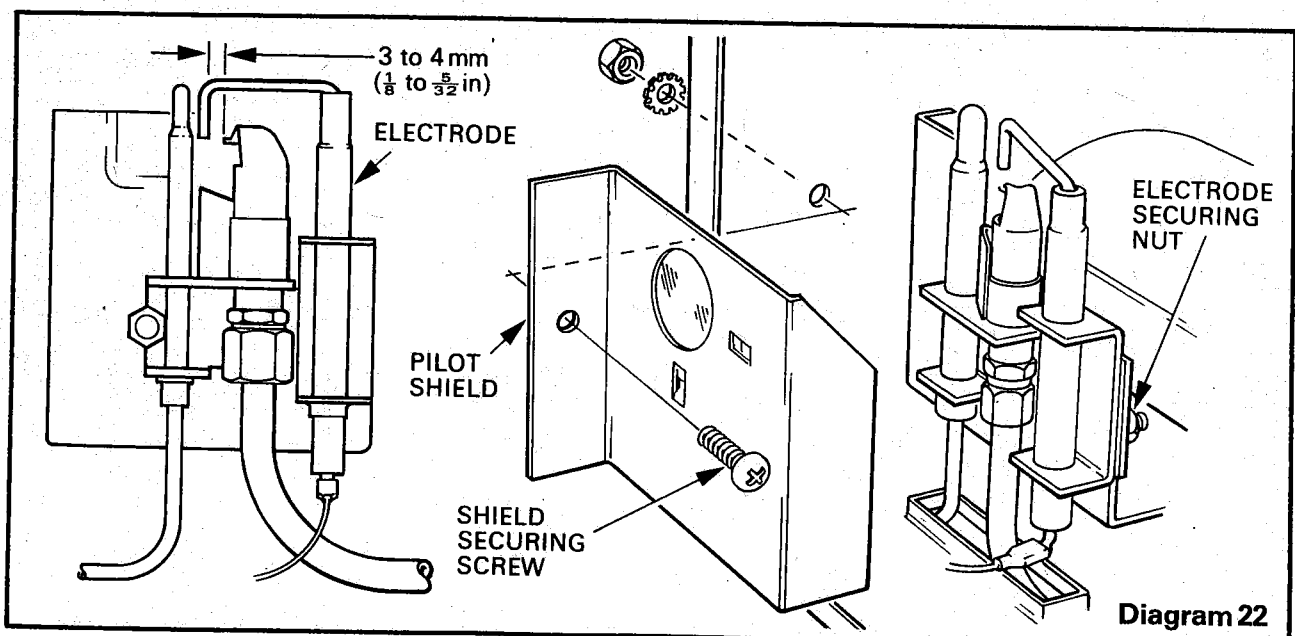

**11.5 Electrode**

11.5.1 Remove front pilot shield as in 11.3.1. Disconnect the lead from the electrode and remove the hex. nut from the stud securing the electrode to the pilot bracket then remove the electrode complete with its bracket. Replace by reversing the above procedure and ensure that the electrode is correctly positioned. (See diagram 22).

NOTE: For items 11.6 to 11.8, remove outer casing as in 10.1.1 also controls cabinet base/door assembly by removing the two securing screws, (See diagram 20).

**11.6 Electrical Control Drawer**

11.6.1 Remove control drawer securing screw, see diagram 10.

11.6.2 Remove thermostat phial from pocket in boiler body.

11.6.3 Remove the gland plates 'R' on the boiler back plate see diagram 19.

11.6.4 Draw the control drawer forwards far enough to disconnect all electrical leads. The drawer can then be removed, withdrawing the thermostat capillary through the back panel.

11.6.5 Replace in reverse order, for details of wiring see diagram 11 and 12 or 14 and 15. Ensure that the thermostat phial is secured in the pocket by the retainer. Leave clearance between capillary and boiler, also make a good seal at the gland plates 'R'.

**11.7 Boiler Thermostat**

11.7.1 Remove control drawer as in 11.6, pull off thermostat control knob.

11.7.2 Slacken the screw securing the thermostat capillary clip to the control drawer and release the capillary.

11.7.3 Pull off the two amp tag connection on top of the thermostat. Remove the two screws securing the thermostat to the control drawer. The thermostat may now be removed. Withdraw the thermostat phial through the square cut-out in the rear of the control drawer.

11.7.4 Replace in reverse order, making sure that the amp tag connections on the thermostat are at the top. Leave clearance between capillary and boiler, also make a good seal at the gland plates 'R'.

**11.8 Ignition Lead**

11.8.1 Remove combustion chamber shield by lifting slightly to clear the lugs, then withdraw.

10.8.2 Remove L.H. gland plates 'R'.

11.8.3 See 11.9.1 and 11.9.2.

11.8.4 Pull off tag connections at bottom of electrode. The lead can then be removed, threading it through the gland plate aperture and through the small grommet in the main panel.

11.8.5 Replace in reverse order, making sure that the gland plates make a good seal.

**11.9 Piezo Unit**

11.9.1 Open controls door and remove the control drawer securing screw, see diagram 10. Pull the control drawer forward off its slide.

11.9.2 Pull off ignition lead from the tag on the piezo unit.

11.9.3 The piezo unit can now be removed by undoing the screw securing it to the front of the controls cabinet.

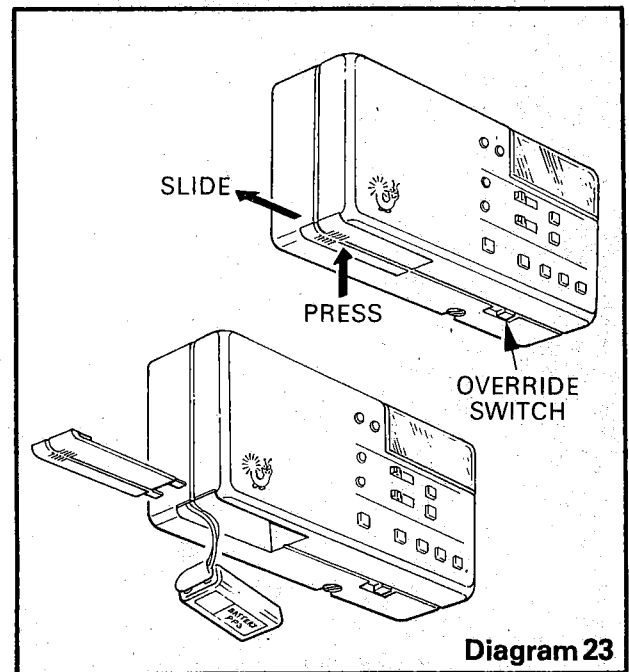

**11.10.1 Replacement of Battery**

The battery is located inside a small compartment within the programmer body, see diagram 23 replacement of the battery is as follows:

11.10.2 Open controls door.

11.10.3 Press and Slide the battery compartment cover, located on the L.H. underside of the programmer body, outwards from Right to Left, See Diagram 23.

11.10.4 Remove the battery from its compartment and disconnect the leads.

11.10.5 Replacement is a reversal of the above procedure.

11.10.6 Ensure that the battery is fitted as shown in diagram 23.

## 12 FAULT FINDING

### 12 FAULT FINDING CHART

#### 12.1 PILOT WILL NOT LIGHT

| Cause   | Remedy   |
|---|--|
| 12.1.1 Air in gas line  | Purge out air.   |
| 12.1.2 Gas supply to pilot restricted:<br>(Check by applying match to pilot instead pressing igniter).<br>(a) On undoing the tubing nut at pilot multi-functional control and pressing knob, gas does not flow freely.<br>(b) On undoing tubing nut at burner and pressing control knob, gas does not flow freely.<br>(c) As 12.1.2 (b) but gas does flow freely. | Rectify blockage in multi-function control. Ensure pilot throttle is fully open<br><br>Change blocked pilot tube.<br><br>Rectify blockage in pilot injector or pilot head. Pull ignition lead off electrode. Hold end of lead close to burner and operation piezo unit. If no spark, change ignition lead and/or piezo unit. |
| 12.1.3 No spark.  | Re-position electrode as shown in diagram 22.  |
| 12.1.4 Electrode not correctly positioned in relation to pilot head.  |  |

#### 12.2 PILOT WILL NOT STAY ALIGHT WHEN CONTROL KNOB IS RELEASED

| Cause   | Remedy  |
|---|---|
| 12.2.1 Pilot flame not impinging on thermocouple. | Check pilot injector or pilot gas adjustment. |

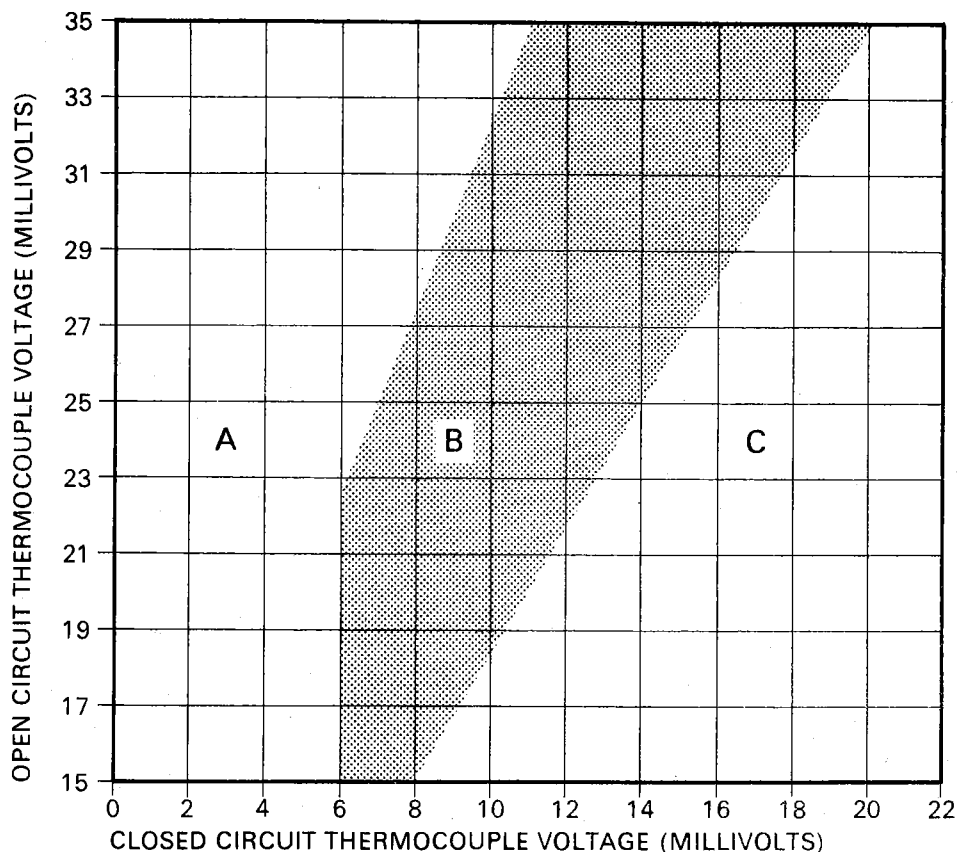

DIAGNOSIS GRAPH FOR THERMOCOUPLE CIRCUIT

12.2.2 To test the thermocouple a meter with a range of 0 - 30 mV is required together with a thermocouple interruptor test unit similar to the B.G.C. (Minitest 6) Multimeter and interruptor.

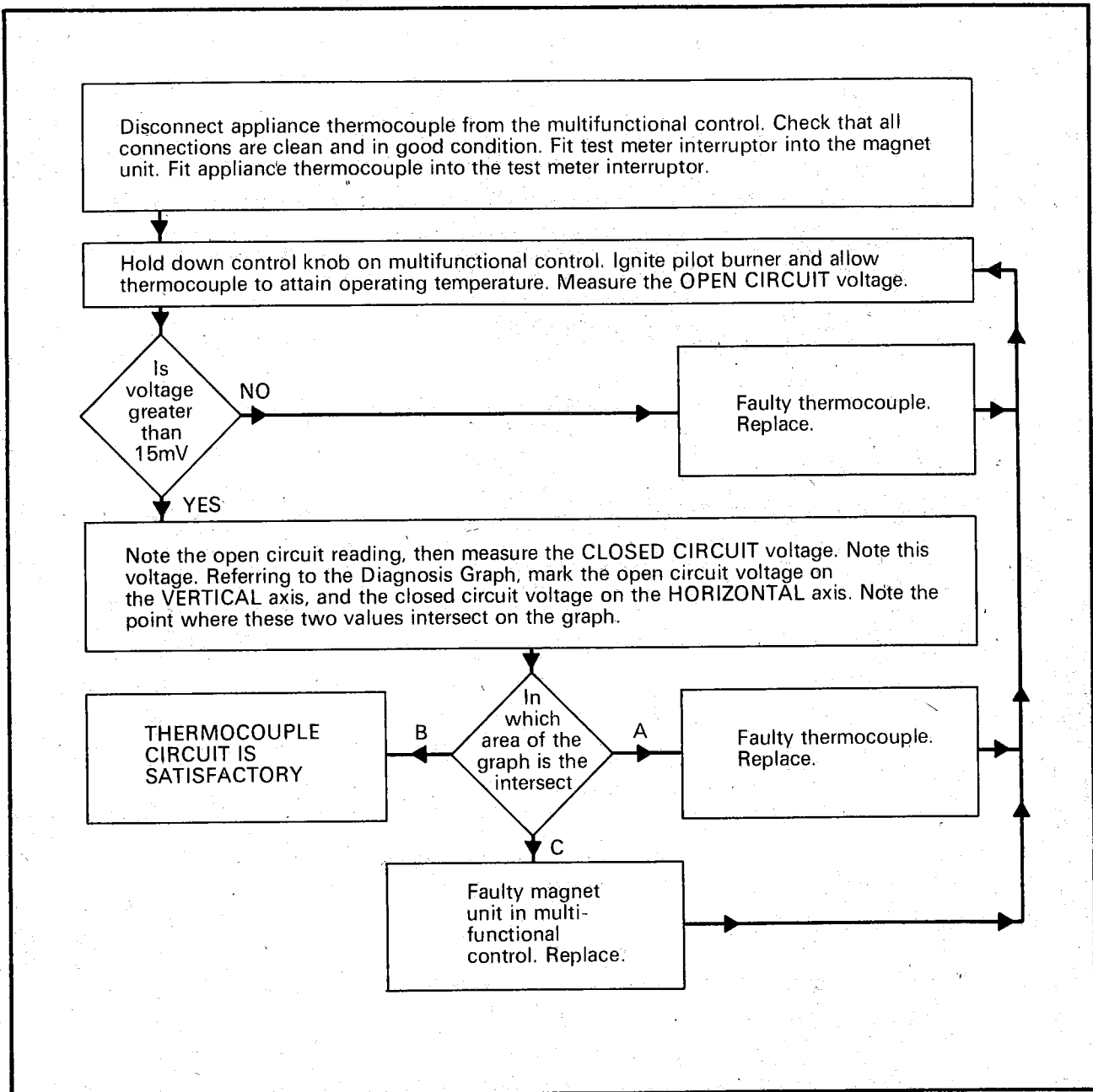

## 12 FAULT FINDING

12.3 Electrical fault finding. Refer to wiring diagram when using this chart (Diagram 24 or 25).

12.4 IMPORTANT:- The preliminary electrical system checks as contained in the British Gas Multimeter instructions book are the first checks

to be carried out during a fault-finding procedure. On completion of the service fault-finding task which has required the breaking and re-making of electrical connections then the checks 'A' Earth continuity, 'C' Polarity, 'D' Resistance to Earth must be repeated.

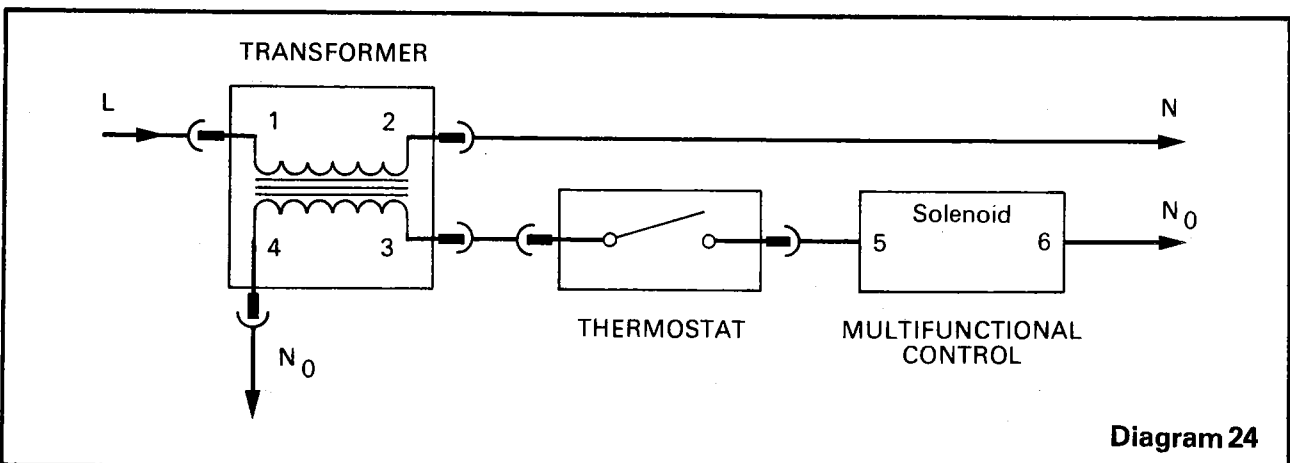
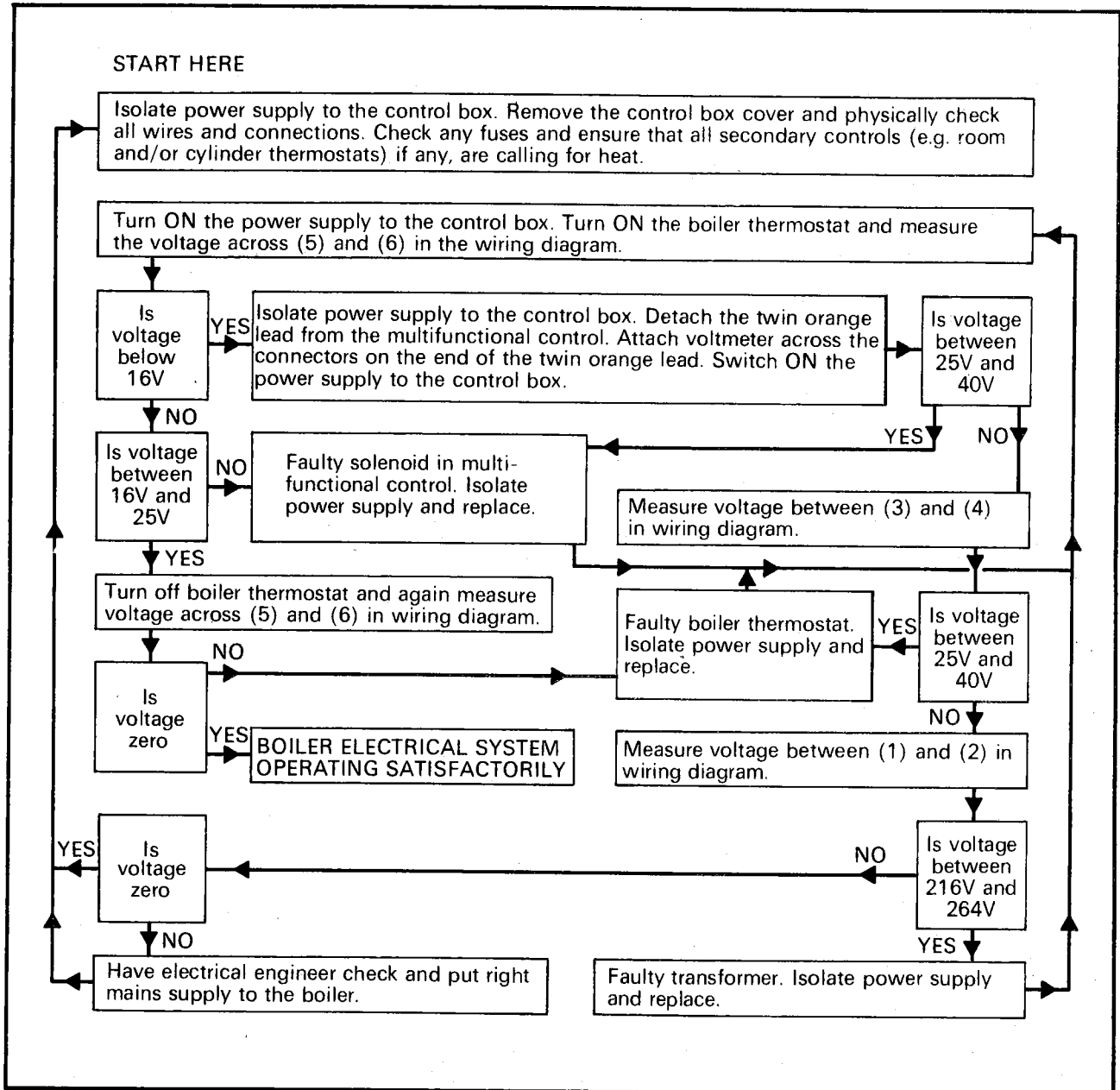

12.5 Programmer fault finding. Refer to wiring diagram (diagram 25) when using this chart.  
**IMPORTANT:-** See note 12.4 on preliminary electrical system checks.

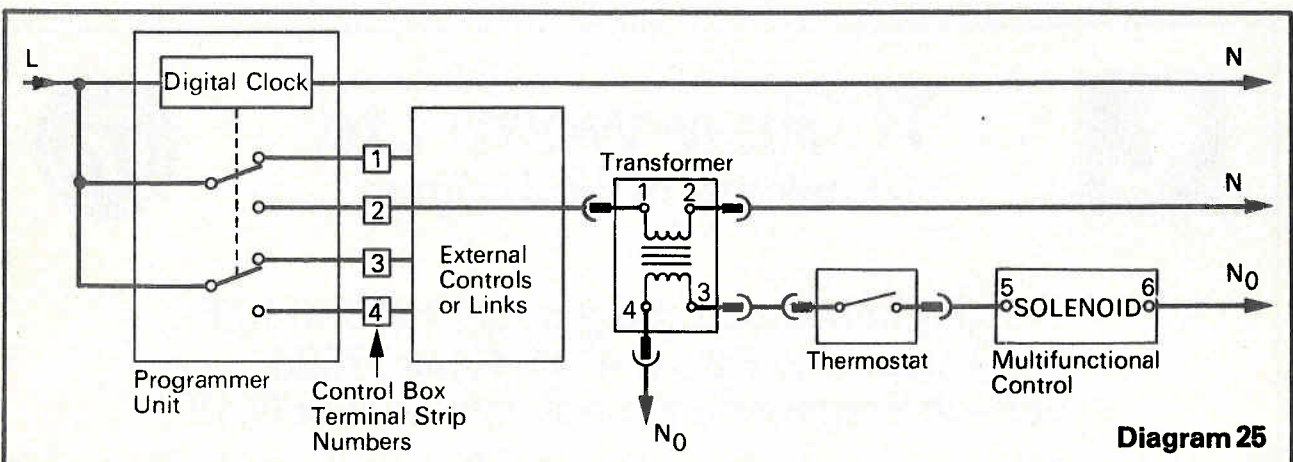
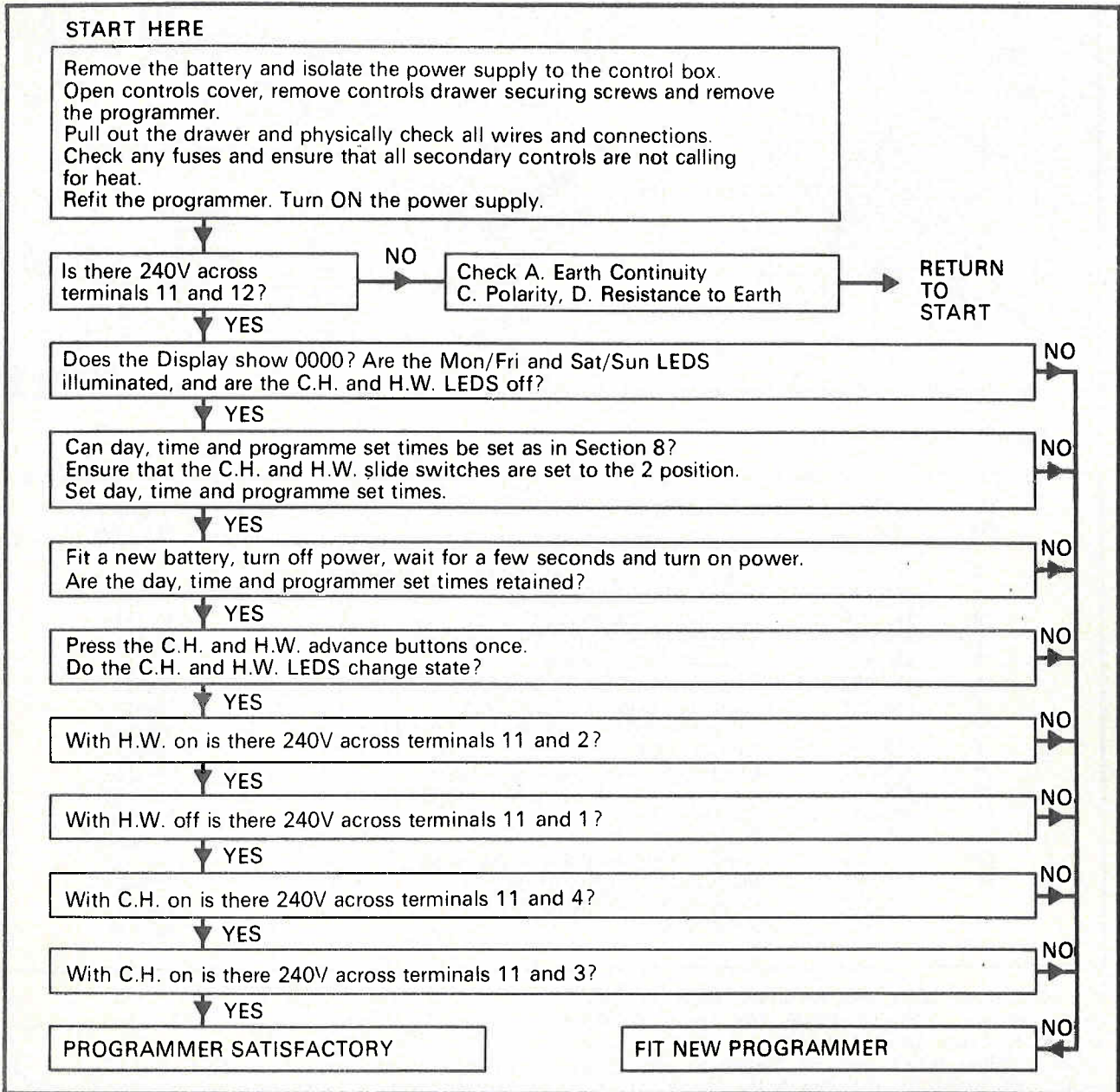

## 13 REPLACEMENT PARTS

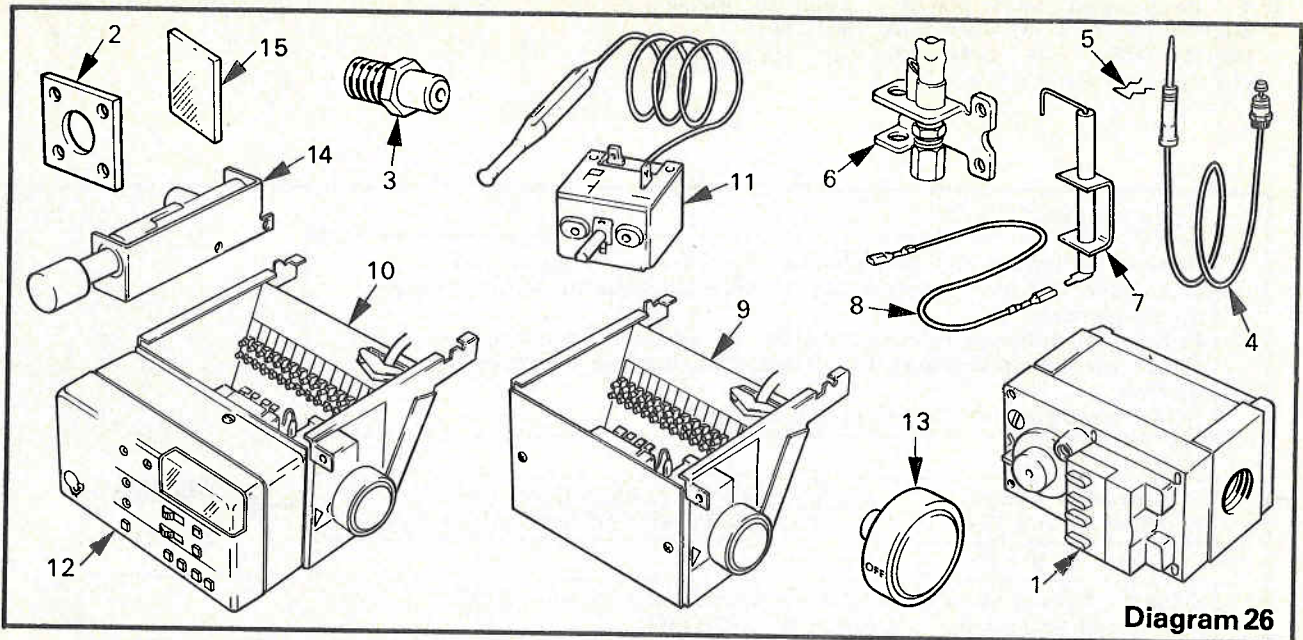

Diagram 26

### 13. REPLACEMENT PARTS

| Key No. | G.C. Part No. | Description                                 | Maker's Part No. |
|---------|---------------|---|------------------|
| 1       | 382 767       | ½ in. B.S.P. gas valve, Maclaren UK48/RBB05 | K9049            |
| 2       | 355 229       | Gasket - burner manifold                    | FF2047           |
| 3       | 355 159       | Injector - marked 2022                      | FF2022           |
| 4       | 390 894       | Thermocouple - Maclaren 2500M-36            | K2674            |
| 5       | 390 983       | Clip for thermocouple                       | K3580            |
| 6       | 391 535       | Pilot Burner - Maclaren 26T 0166 TL016      | K8356            |
| 7       | 382 555       | Spark electrode - Kigass 7705               | FF2142           |
| 7       |               | Spark electrode - Buccleuch DE/3158/S1      | FF2143           |
| 8       | 355 163       | Ignition lead                               | FF1101           |
| 9       | 355 230       | Electrical control Drawer - Basic           | FF1208           |
| 10      | 355 243       | Electrical control Drawer - Programmer      | FF1209           |
| 11      | 382 393       | Thermostat - Ranco CL6 P0102                | FF2130           |
| 12      | 355 244       | Programmer Unit                             | AA219K           |
| 13      | 351 828       | Control knob assembly - thermostat          | FF2227           |
| 14      | 387 907       | Piezo unit - Kigass 05037                   | K6587            |
| 14      | 393 563       | Piezo unit - Vernitron 66108                | K6587            |
| 15      | 355 153       | Sight Window                                | 411194           |

If replacement parts are required, apply to your local supplier. Please quote the name of the appliance, Space Saver 50B-MkII and preferably its serial number which can be found on the data badge positioned at the top R.H. corner of the main panel.

Because of our constant endeavour for improvement, details may vary slightly from those quoted in this booklet.



**TI Glow-worm Ltd**  
A member of the TI Group



Nottingham Road, Belper, Derby DE5 1JT  
Telephone Belper 4141 Telex 37586  
Service Engineer Enquiries only Belper 6516