

Installation Instructions

To be left with the user

*SWIFT
FLOW*

75

G.C. No. 47 313 14 Honeywell
G.C. No. 47 313 15 SIT

Fanned Flue Combination Boiler

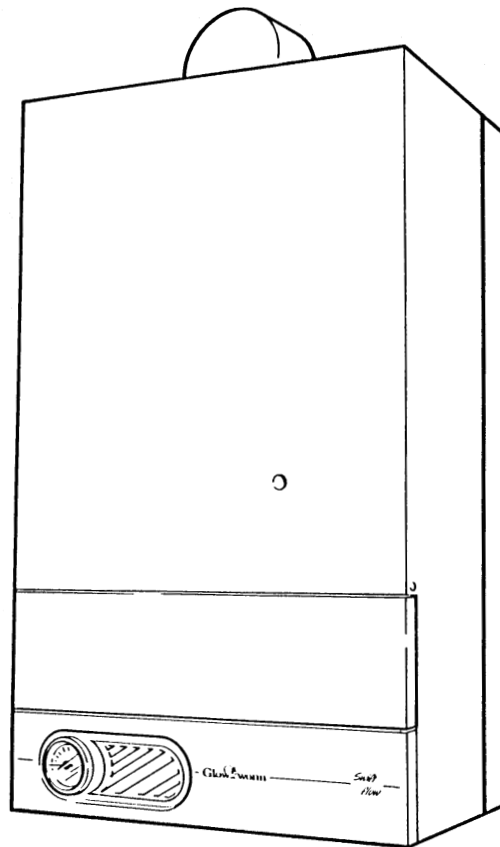

3892



This is a Cat I_{2H} Appliance

HEATCALL

Customer Services:

Tel: (01773) 828100

One Contact Total Service

Fax: (01773) 828070

Hepworth Heating Ltd.,

Nottingham Road, Belper, Derbyshire. DE56 1JT

General/Sales enquiries:

Tel: (01773) 824141 Fax: (01773) 820569

1 General

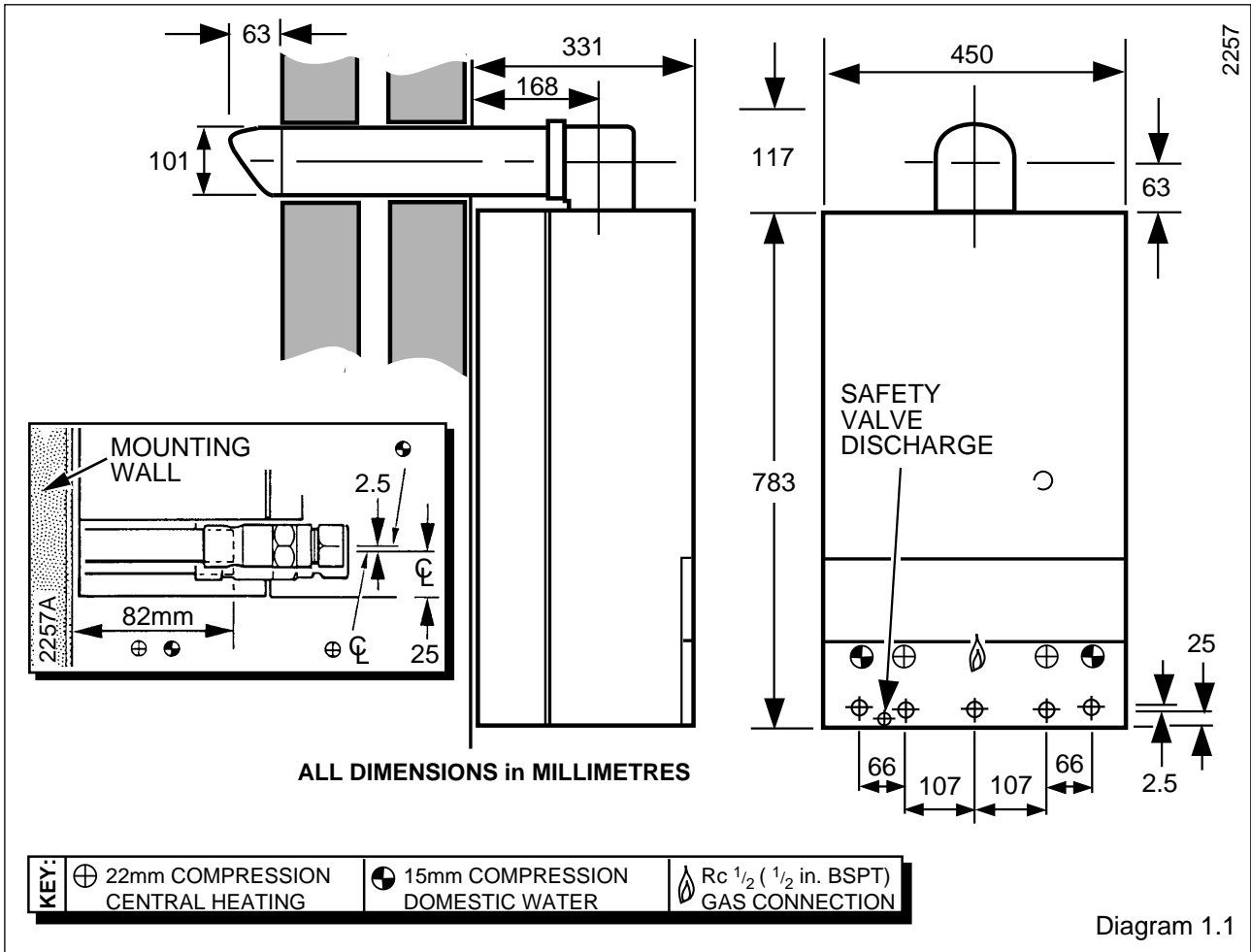

Diagram 1.1

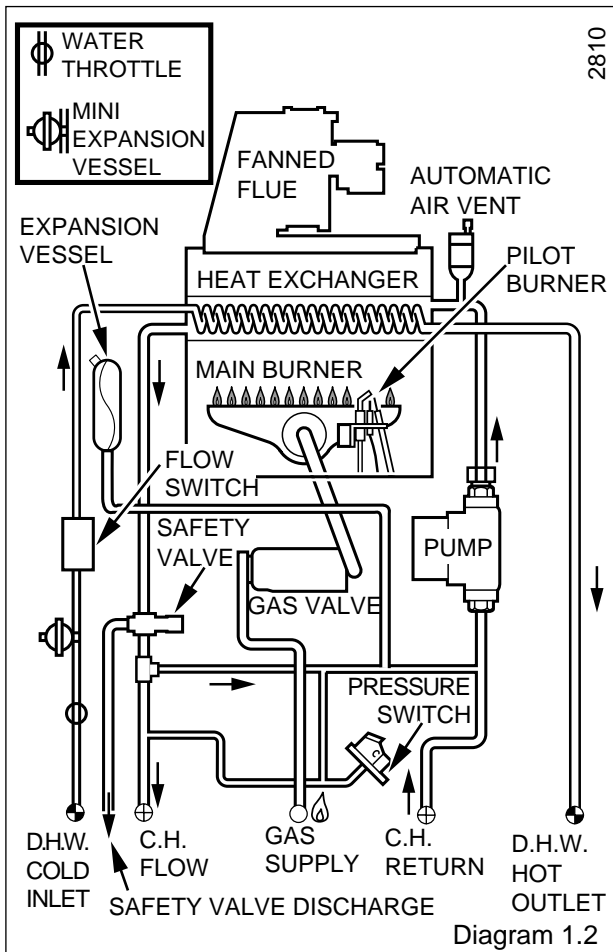

TABLE 1 Honeywell		C.H. MAX	D.H.W. MAX	MIN
NOMINAL HEAT INPUT	kW	20.7	27.5	12.5
	Btu/h	70500	93750	42675
NOMINAL HEAT OUTPUT	kW	16.1	22.0	8.8
	Btu/h	55000	75000	30000
BURNER PRESSURE	m bar	9.0	16.1	2.9
	in.wg	3.6	6.5	1.2
APPROX. GAS RATE	m ³ /h	2.0	2.6	1.2
	ft ³ /h	69.5	92.5	42.1

TABLE 1 SIT		C.H. MAX	D.H.W. MAX	MIN
NOMINAL HEAT INPUT	kW	20.7	27.5	12.5
	Btu/h	70500	93750	42675
NOMINAL HEAT OUTPUT	kW	16.1	22.0	8.8
	Btu/h	55000	75000	30000
BURNER PRESSURE	m bar	8.8	15.7	2.9
	in.wg	3.5	6.3	1.2
APPROX. GAS RATE	m ³ /h	2.0	2.6	1.2
	ft ³ /h	69.5	92.5	42.1

1 General

The instructions consist of three parts, Installation, Servicing and Instructions for Use, which includes the Guarantee Card. The instructions are an integral part of the appliance and must, to comply with the current issue of the Gas Safety (Installation and Use) Regulations, be handed to the user on completion of the installation.

Testing and Certification

This boiler is tested and certificated for safety and performance. It is therefore important that no alteration is made to the boiler, without permission, in writing, from Hepworth Heating Ltd.

Any alteration not approved by Hepworth Heating Ltd., could invalidate the certification, boiler warranty and may also infringe the current issue of the Statutory Requirements, see Section 1.4.

CE Mark

The CE mark on this appliance shows compliance with:

1. Directive 90/396/EEC on the Approximation of the Laws of the Member States relating to appliances burning gaseous fuels.
2. Directive 73/23/EEC on the harmonization of the Laws of the Member States relating to the electrical equipment designed for use within certain voltage limits.
3. Directive 89/336/EEC on the approximation of the Laws of the Member States relating to the electromagnetic compatibility.

This boiler will be fitted with either a Honeywell or SIT Gas Valve. The valve used can be identified as shown:



1.1 Installation

Material and equipment should be fit for their purpose and of suitable quality and workmanship.

1.2 Important Notice

This boiler is for use with natural gas as distributed in the United Kingdom and Ireland (G20) and cannot be used on any other gas.

1.3 Sheet Metal Parts

WARNING. When installing or servicing this boiler care should be taken when handling the edges of sheet metal parts to avoid any possibility of personal injury.

1.4 Requirements

The installation of this boiler must be carried out by a competent person in accordance with the rules in force in the countries of destination.

The manufacturer's instructions supplied.

Manufacturer's instructions must not be taken as overriding statutory requirements.

1.5 Data Label

The data label is at the top right hand side of the inner case.

1.6 Data

WEIGHT	47.2kg (104lb)
GAS CONNECTION	Rc ¹ / ₂ (1 ¹ / ₂ in BSP)
HEATING FLOW AND RETURN	22mm compression
D.H.W INLET AND OUTLET	15mm compression (Ball valves are incorporated in water and gas connections plus a drain point on all water connections).
SAFETY VALVE	preset 3bar (43.5lbf/in ²)
SAFETY VALVE DISCHARGE	15mm compression
WATER CONTENT	1.74Litre (0.38gall)
EXPANSION VESSEL	8Litre
CAPACITY	(1.76gall)
HEATING COLD FILL PRESSURE	0.7bar (10.1lbf/in ²) minimum
D.H.W WORKING PRESSURE	0.5 to 10bar (7.25 to 188lbf/in ²)
MAXIMUM HEATING SYSTEM WATER CONTENT	119Litre (26.2gall) (Larger systems will require an additional expansion vessel, refer to Section 4).
ELECTRICAL SUPPLY	240V~50Hz
ELECTRICAL RATING	150W, fused 3A

1 General

1.7 Gas Supply

The gas installation shall be in accordance with the rules in force in the countries of destination.

The supply from the governed meter must be of adequate size to provide a steady inlet working pressure of 20mbar (8in wg) at the boiler.

1.8 Electrical Supply

WARNING. This boiler must be earthed.

All system components shall be of an approved type.

The electrical installation must be in accordance with the rules in force in the countries of destination.

Connection of the whole electrical system of the boiler and any heating system controls to the electrical supply, must be through one common isolator.

Isolation should be by a double pole switched fused spur box, having a minimum contact separation of 3mm in each pole. The fused spur box should be readily accessible and preferably adjacent to the appliance. It should be identified as to its use.

Alternatively, a fused 3A 3pin plug and unswitched socket may be used, provided they are not used in a room containing a bath or shower.

The mains supply cable and other cables connected to the boiler must be the PVC flexible type of at least 0.75mm² (24/0.20mm).

2 Boiler Position

2.1 Location

This boiler must be installed in accordance with the rules in force in the countries of destination.

This boiler is not suitable for fitting outside.

Any electrical switch must be positioned so that it cannot be touched by a person using the bath or shower.

The boiler must be mounted on a flat wall which is sufficiently robust to take its weight, refer to Section 1, "Data".

If the location of the boiler or any part of the system is subject to severe cold weather conditions, it is recommended that a frost thermostat is fitted. Any part of the system that may be vulnerable to freezing must be protected.

If the boiler is to be fitted into a cupboard, compartment or unusual location, special procedures are necessary.

Make sure that the cupboard or compartment air vents are positioned to be clear of obstructions at all times, refer to Section 3, Cupboard/Compartment Ventilation.

2.2 Clearances

The boiler should be positioned so that at least the minimum operational and servicing clearances are provided, see diagram 2.1. Additional clearances may be required around the boiler for installation.

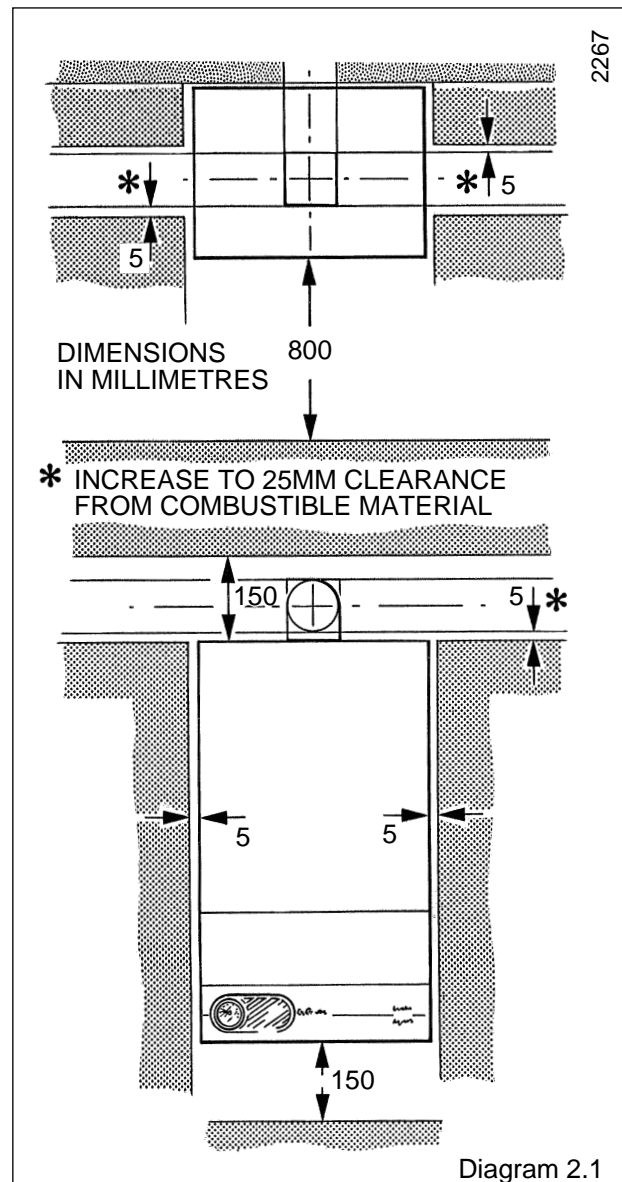

3.1 Flue

The flue must be installed in accordance with the rules in force in the countries of destination.

3.2 Flue Position and Length

The air and flue ducting connect to the top of the boiler using the elbow which can be positioned in one of three possible directions:

Rearward, left or right.

The standard flue is able to provide the duct length range shown in diagram 3.1 for a rear flue or diagram 3.2 for a side flue.

If a longer flue duct is required, do not extend the ductings.

A 1, 2 or 3 metre flue system and elbow / terminal kit must be used and can be supplied. This is able to provide the duct length range shown in diagram 3.3 for rear flue or diagram 3.4 for a side flue.

A Flue Bend Kit or Vertical Flue Kit can be supplied with instructions.

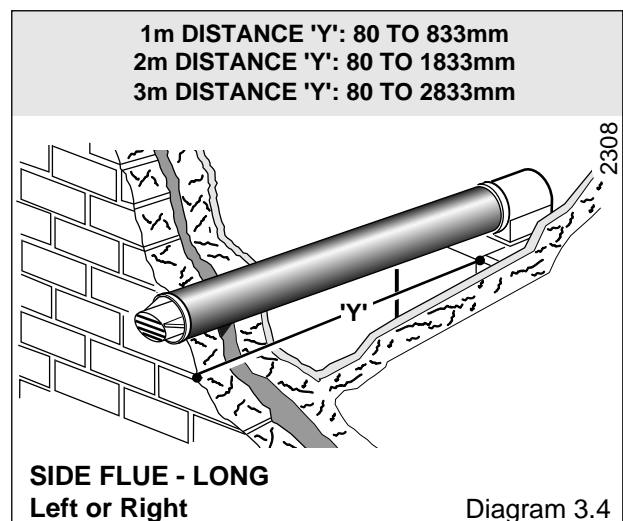
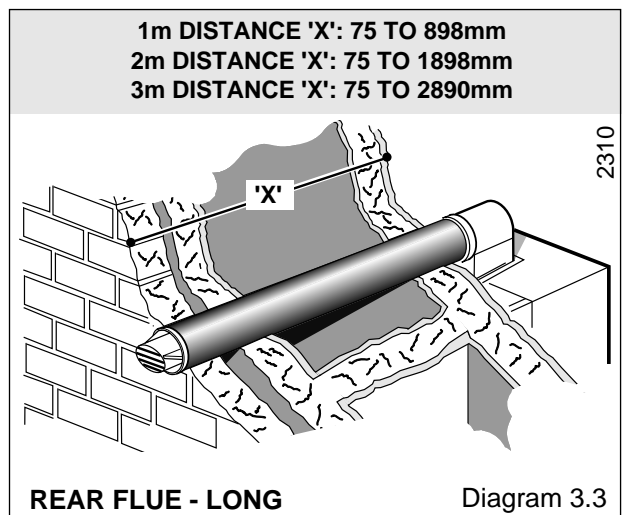
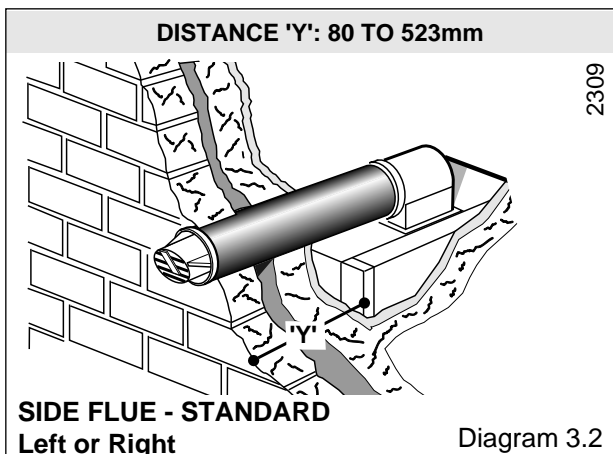
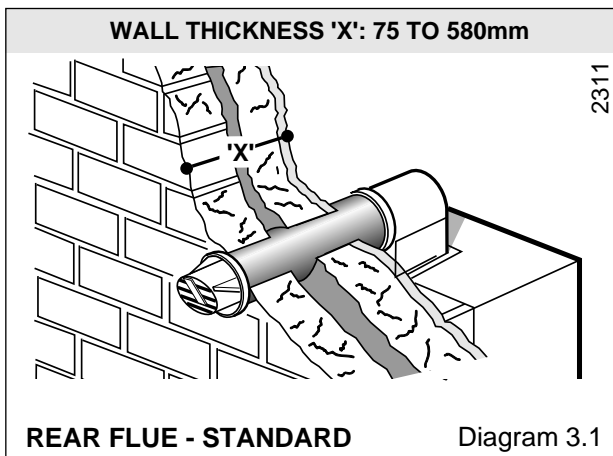

HORIZONTAL FORWARDS or BACKWARDS

ELBOW / 2 x 90° BENDS

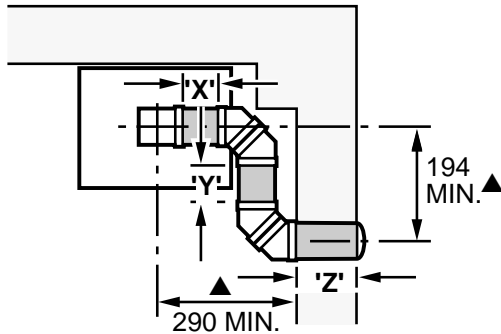

MAX. FLUE LENGTH X+Y+Z = 600mm*		
FLUE BEND KIT	Part No.438130	2 off
FLUE KIT 1m	Part No.448490	1 off
ELBOW/TERMINAL PACK	Part No.448468	1 off

HORIZONTAL and DOWNWARDS

ELBOW / 2 x 90° BENDS

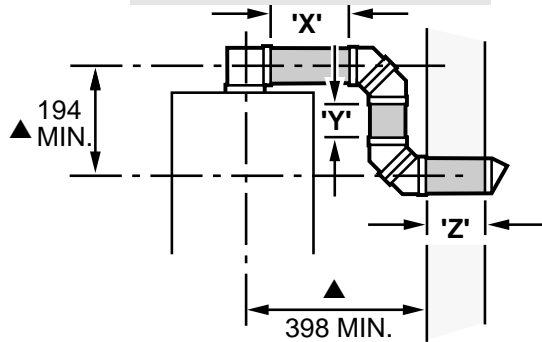

3526

MAX. FLUE LENGTH X+Y+Z = 600mm*		
FLUE BEND KIT	Part No.438130	2 off
FLUE KIT 1m	Part No.448490	1 off
ELBOW/TERMINAL PACK	Part No.448468	1 off

ELBOW / 2 x 45° BENDS

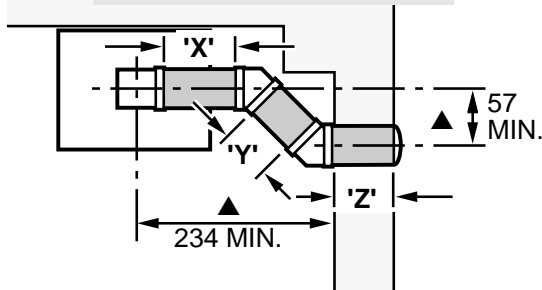

MAX. FLUE LENGTH X+Y+Z = 1800mm*		
FLUE BEND KIT	Part No.438130	1 off
FLUE KIT 1m	Part No.448490	1 off
FLUE KIT 2m	Part No.448491	1 off
ELBOW/TERMINAL PACK	Part No.448468	1 off

ELBOW / 2 x 45° BENDS

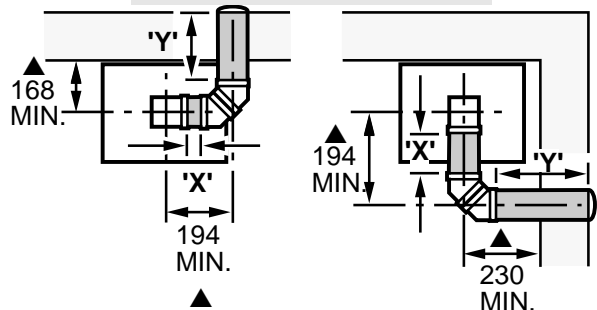

MAX. FLUE LENGTH X+Y = 1800mm*		
FLUE BEND KIT	Part No.438130	1 off
FLUE KIT 1m	Part No.448490	1 off
FLUE KIT 2m	Part No.448491	1 off
ELBOW/TERMINAL PACK	Part No.448468	1 off

ELBOW / 2 x 45° BENDS

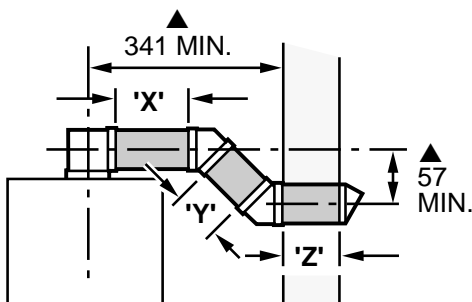

MAX. FLUE LENGTH X+Y+Z = 1800mm*		
FLUE BEND KIT	Part No.438130	1 off
FLUE KIT 1m	Part No.448490	1 off
FLUE KIT 2m	Part No.448491	1 off
ELBOW/TERMINAL PACK	Part No.448468	1 off

KEY

* = The maximum 'Flue Length' does not include the elbows.

▲ = Installation clearance

IMPORTANT

For every 45° bend used the straight flue length of 2metres must be decreased by 600mm minimum, this must be taken into account when measuring the total flue length.

Diagram 3.5

3.3 Terminal Position

The minimum acceptable siting dimensions for the terminal from obstructions, other terminals and ventilation openings are shown in diagram 3.5.

The terminal must be exposed to the external air, the position allowing free passage of air across it at all times.

Car port or similar extensions of a roof only, or roof and one wall, require special consideration with respect to any openings, doors, vents or windows under the roof. Care is required to protect the roof if made of plastic sheeting. If the car port comprises of a roof and two or more walls seek advice from the local gas undertaking before installing the boiler.

If the terminal is fitted within 600mm below plastic guttering, an aluminium shield 1500mm long should be fitted immediately beneath the guttering or eaves. If the terminal is fitted within 450mm below painted eaves or a painted gutter, an aluminium shield 750mm long should be fitted immediately beneath the guttering or eaves.

3.4 Timber Frame Buildings

If the boiler is to be installed in a timber frame building, seek advice from the local gas undertaking or from Hepworth Heating Ltd.

3.5 Terminal Guard

A terminal guard is required if persons could come into contact with the terminal or the terminal could be subject to damage.

If a terminal guard is required, it must be positioned to provide a minimum of 50mm clearance from any part of the terminal and be central over the terminal.

The guard should be similar to that shown in diagram 3.6 and can be bought from:

Tower Flue Components Ltd.,
Morely Road,
Tonbridge,
Kent.
TN9 1RA

their type K3.

3.6 Room Ventilation

Ventilation must be provided in accordance with the rules in force in the countries of destination. The boiler is room sealed, so where the boiler is fitted in a room or space, a permanent air vent is not required.

3.7 Cupboard/Compartment Ventilation

If the boiler is to be fitted in a cupboard or compartment, permanent high and low level air vents must be provided. The vents must have at least the effective areas shown in Table 2.

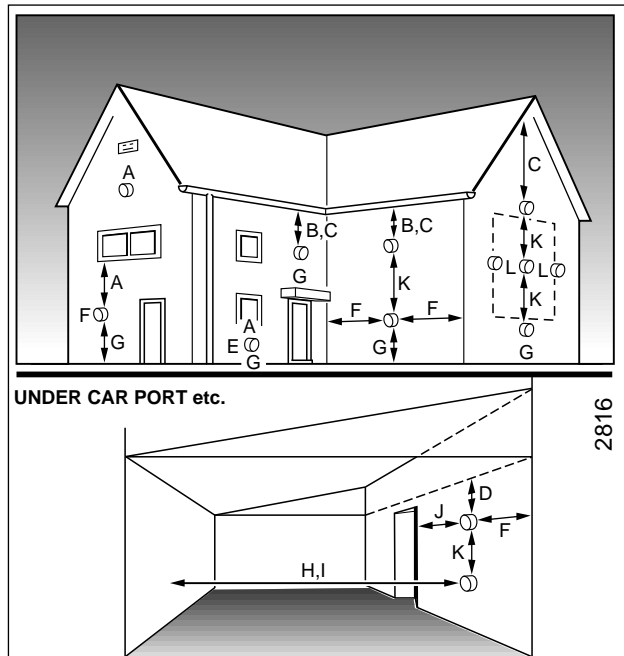

MINIMUM SITING DIMENSIONS FOR FANNED FLUE TERMINALS POSITION

MINIMUM SPACING

	MM
A DIRECTLY BELOW AN OPENABLE WINDOW, AIR VENT, OR ANY OTHER VENTILATION OPENING	300
B BELOW GUTTER, DRAIN/SOIL PIPE	75
C BELOW EAVES	200
D BELOW A BALCONY OR CAR PORT	200
E FROM VERTICAL DRAIN PIPES AND SOIL PIPES	75
F FROM INTERNAL OR EXTERNAL CORNERS	300
G ABOVE ADJACENT GROUND OR BALCONY LEVEL	300
H FROM SURFACE FACING THE TERMINAL	600
I FACING TERMINALS	1200
J FROM OPENING (DOOR/WINDOW) IN CAR PORT INTO DWELLING	1200
K VERTICAL FROM A TERMINAL	1500
L HORIZONTALLY FROM A TERMINAL	300

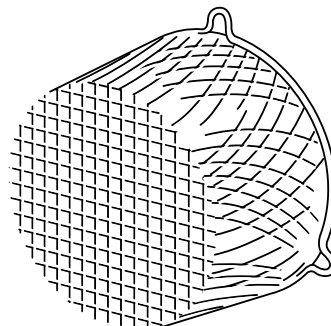
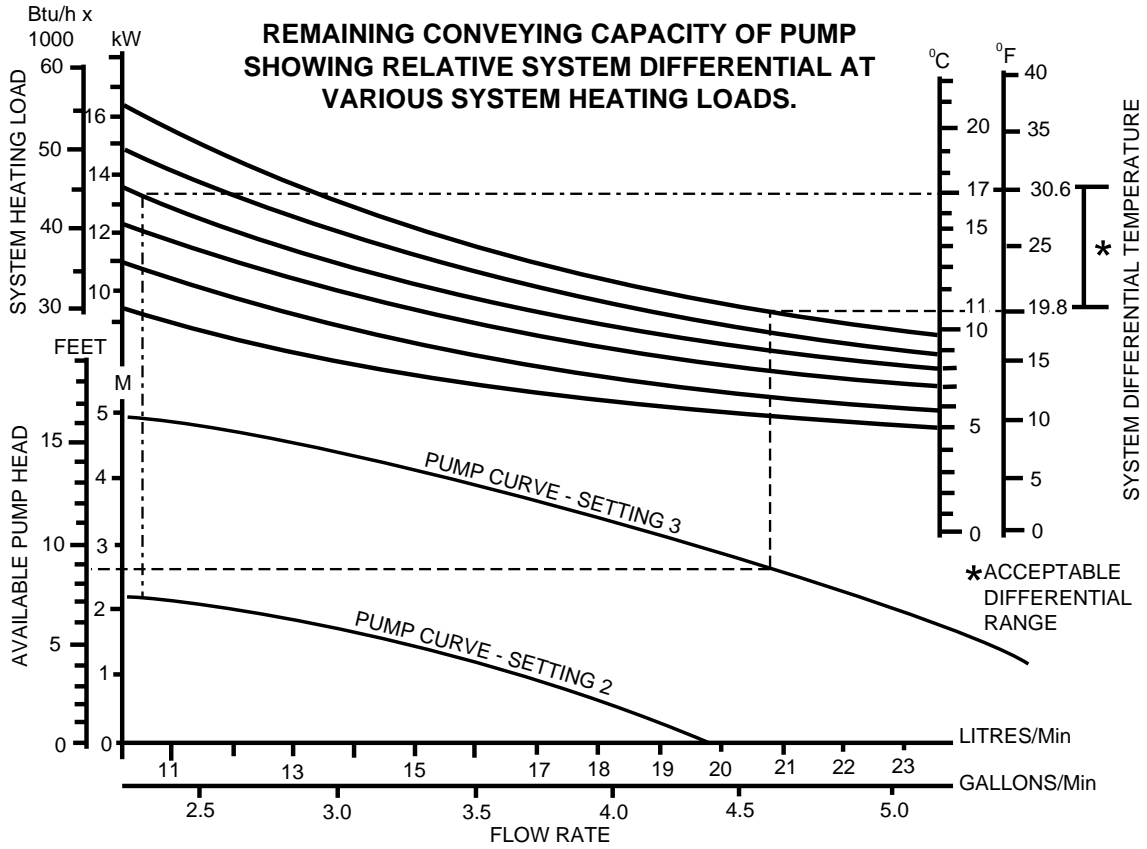

Diagram 3.6

Position of Air Vent	Air from Room or Internal space	Air Direct from Outside
High Vent	248cm ² 38in ²	124cm ² 19in ²
Low Vent	248cm ² 38in ²	124cm ² 19in ²

5947



GRUNDFOS

Diagram 4.1

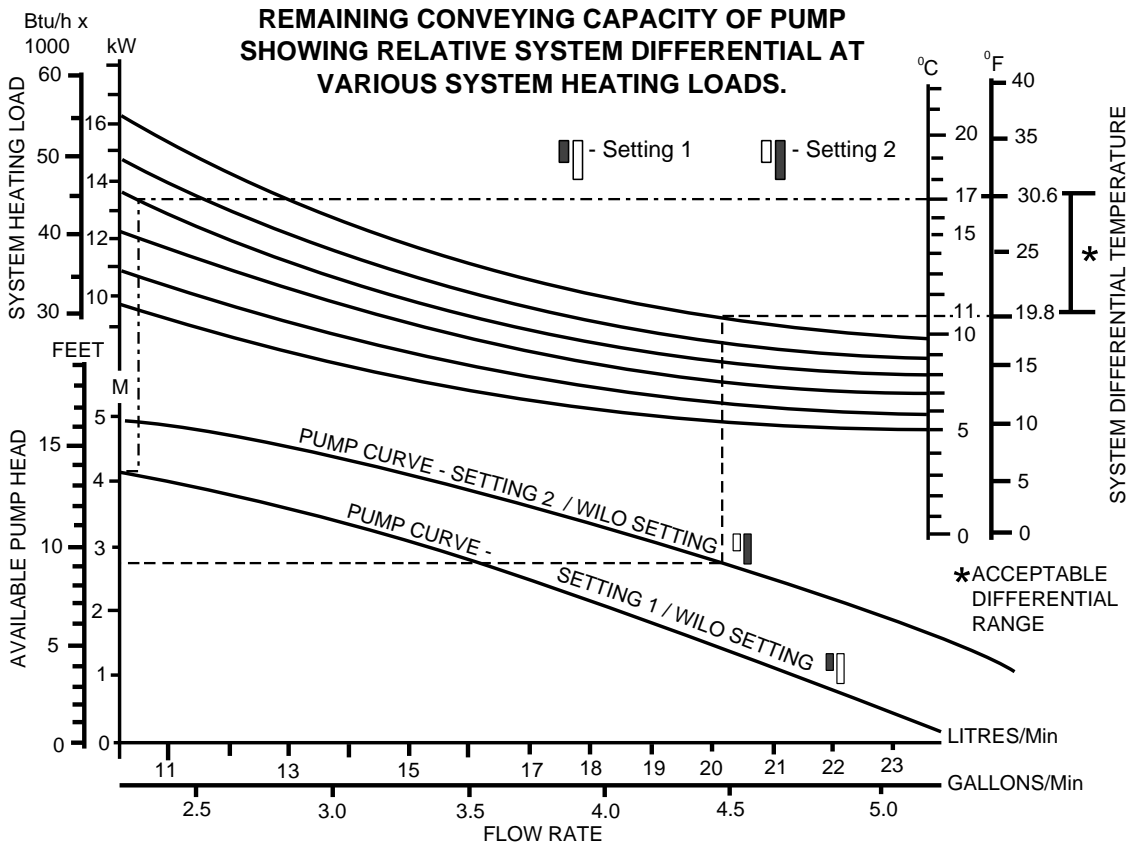

WILO

Diagram 4.1A

4.1 General Notes

The boiler is intended for use in a sealed system only.

4.2 Safety Valve

The safety valve is an integral part of the boiler.

It cannot be adjusted but has a manual test device.

4.3 Pressure Gauge

A pressure gauge is incorporated into the boiler to indicate the system pressure.

The gauge has a cold fill set pointer.

4.4 Pump

The circulation pump is integral with the boiler.

The remaining circulating pressure head available from the boiler is shown in diagram 4.1, Grundfos or diagram 4.1a, Glow-worm Wilo.

4.5 Expansion Vessel

The boiler has an integral expansion vessel with a capacity of 8Litres, (1.76gall). If the system water content exceeds the maximum quoted in Section 1, Data, an additional vessel should be connected into the system as close as possible to the central heating return connection of the boiler, see diagram 4.2.

The pressure shall not be less than the static head at the point of connection, that is, the height of the top point of the system above the expansion vessel.

4.6 Flow Rate

A valve must be incorporated in the main flow or return of the system, valve "A" shown in the flow diagram 4.2. This valve must be lockable and positioned so that inadvertent closure or unauthorised interference is not possible. The design differential can be between 11°C (20°F) and 17°C (30°F), dependent upon the system resistance and the available pump head.

Grundfos Pump

The pump adjuster should normally be left at maximum (3) but in some cases it is permissible to adjust the pump to a lower setting (2), see diagram 4.1.

To use diagram 4.1 start with the required heating system load.

In the example shown the maximum boiler output has been chosen, 16.1kW (55,000Btu/h).

Draw a horizontal line from the required system differential temperature axis to intersect the curve.

In the example 11°C (19.8°F) has been chosen, shown - - - - -. At the point of intersection draw a vertical line to cross the pump curve, from this point draw a further horizontal line to determine the available pump head. In the example 2.7m (9ft) is available. A greater pump head can be achieved by choosing a higher system differential temperature, up to a maximum of 4.6m (15ft) at a system differential of 17°C (30.6°F). The system must be designed such that the available pump head is not exceeded.

If the heating system load is less than 13.2kW (45,000Btu/h) then it is permissible to adjust the pump setting to (2), shown - - - - -. This results in an available pump head of 2.1m (7ft). This is the maximum that can be achieved with the pump at this setting.

Glow-worm Wilo Pump

The pump adjuster should normally be left at maximum (2) but in some cases it is permissible to adjust to a lower setting (1), see diagram 4.1a.

To use diagram 4.1a start with the required heating system load.

In the example shown the maximum boiler output has been chosen, 16.1kW (55,000Btu/h).

Draw a horizontal line from the required system differential temperature axis to intersect the curve. In the example 11.°C (19.8°F) has been chosen, shown - - - - -. At the point of intersection draw a vertical line to cross the pump curve. From this point draw a further horizontal line to determine the available pump head. In the example 2.7m (9ft) is available. A greater pump head can be achieved by choosing a higher system differential temperature, up to a maximum of 4.6m (15ft) at a system differential of 17°C (30.6°F). The system must be designed such that the available pump head is not exceeded.

If the heating system load is less than 13.3kW (45,000Btu/h) then it is permissible to adjust the pump setting to (1), shown - - - - -. This results in an available pump head of 4.2m (13ft9in). This is the maximum than can be achieved with the pump at this setting.

4.7 Bypass

It is essential that a bypass is fitted in all installations, 22mm o.d. minimum. The bypass must have a lockable valve "B" in diagram 4.2, incorporated in a position so that inadvertent closure or unauthorised interference is not possible.

The bypass **MUST** be fitted before any system control. A radiator bypass is **NOT** recommended.

4.8 Make-up

Provision should be made for replacing water lost from the system using a make up bottle mounted in a position higher than the top point of the system, connected through a non-return valve to the return side of the heating circuit, see diagram 4.2.

Alternatively, provision for make-up can be made by pre-pressurisation of the circuit

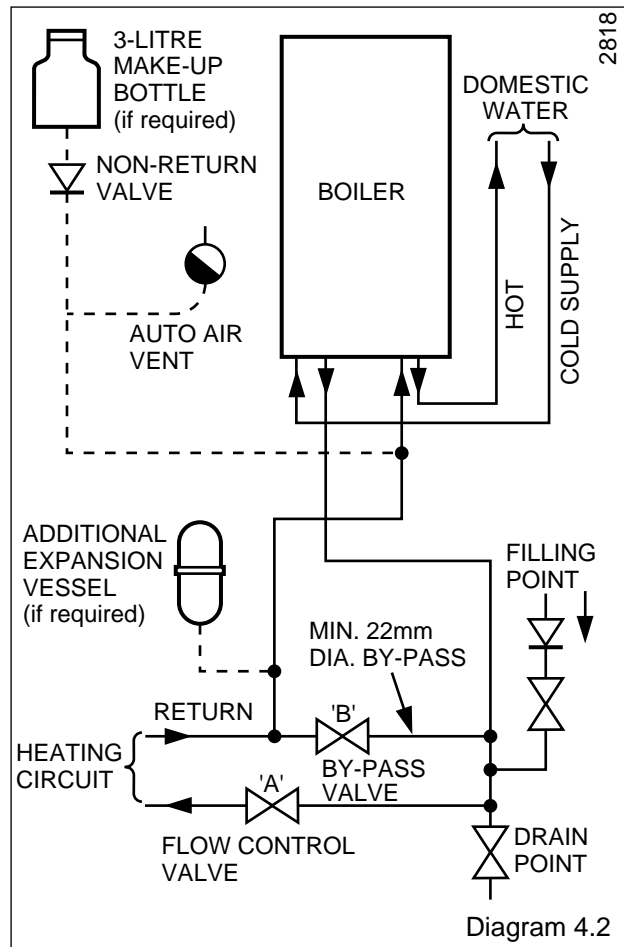

4 Heating System

4.9 Filling Sealed Systems

Provision for filling the system at a low level must be made. Three methods of filling are shown in diagram 4.3.

There must be no permanent connection to the mains water supply, even through a non-return valve.

4.10 Corrosion Inhibitor

If an inhibitor is to be used in the system, contact the inhibitor manufacturer so that they can recommend their most suitable product.

When fitting the boiler into an existing system, special care should be taken to drain the entire system, including radiators, then thoroughly cleaning out before fitting the boiler whether or not adding an inhibitor.

4.11 Draining

A draining tap must be provided at the lowest points of the system, which will allow the entire system to be drained. An additional draining tap **MUST** be fitted close to the boiler.

The flow and return isolation valves are provided with drain points for boiler heat exchanger drainage.

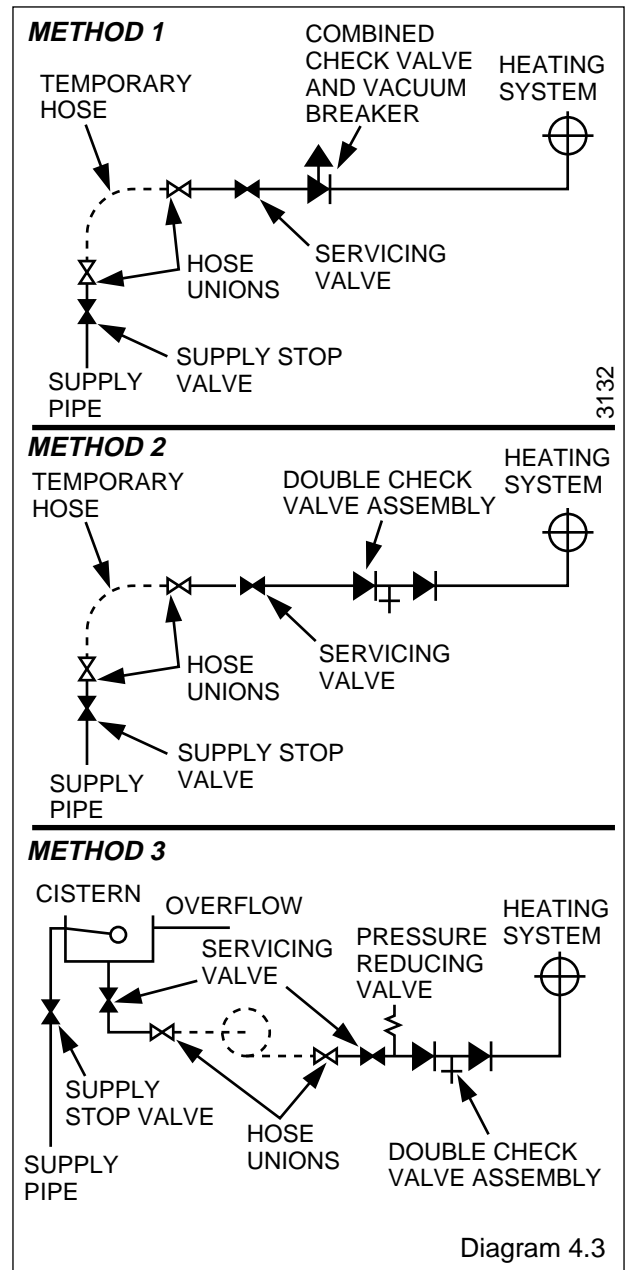

5 Domestic Hot Water System

5.1 General

The domestic hot water service must be in accordance with the rules in force in the countries of destination.

5.2 Water Pressure

For the minimum and maximum working pressures of the domestic hot water circuit of the boiler refer to Section 1.6 Data.

If the cold water supply pressure exceeds the maximum, a governor must be fitted in the supply to the boiler to reduce the pressure to within the limits given.

5.3 "Hard" Water Areas

In areas where the water is "hard", more than 200mg/litre, it is recommended that a proprietary scale reducer is fitted in the cold water supply to the boiler. Check the total water "hardness", using the kit supplied, in the door, following the instructions given. Consult the local water company for additional advice.

A double check valve assembly must be fitted upstream of the scale reducer. For the relative position of the scale reducer and pressure reducing valve, if required, refer to the manufacturer's instructions.

6.1 Unpacking

Remove the top carton and cut out the flue template from the inner flap.

Open the control door, see diagram 6.1.

Remove the two screws securing the outer case and then lift it at the top and pull it forwards and off.

Remove the cover of the inner case, secured with four screws, see diagram 6.2.

Disconnect the gas service cock union and the front unions of the isolation valves, see diagram 6.3.

Slightly loosen the clips of the gas service cock and the isolating valves.

Remove the two boiler securing screws then remove the boiler from the mounting frame, by pulling the studs from the clips and unhooking it at the top.

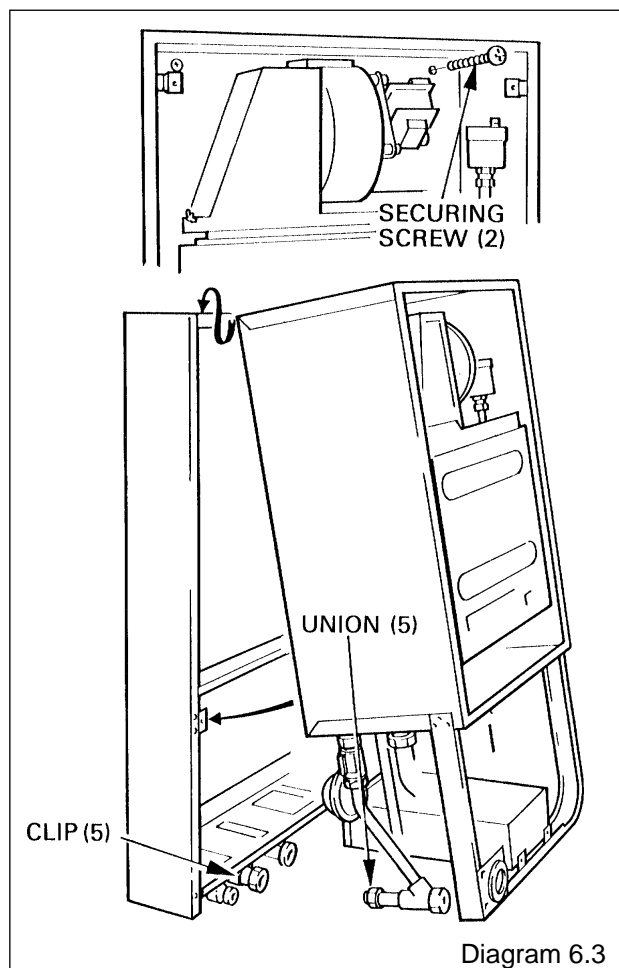
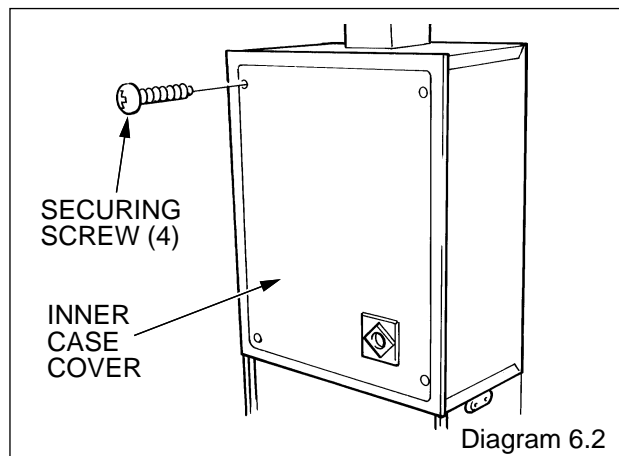
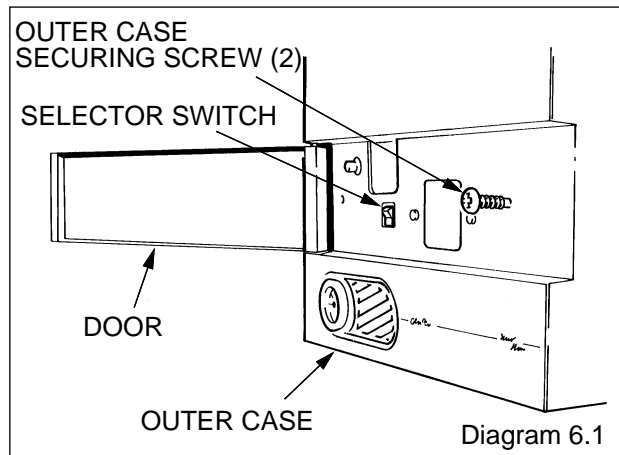

6.2 Marking

The boiler mounting frame is the same width as the boiler but the flue connection sticks out above it.

Place the boiler mounting frame on the wall in the required position, see diagram 2.1 to maintain minimum clearances. Make sure that the isolation valves are at the bottom facing forwards and that the frame top is horizontal, then mark the four wall fixing points through the holes in the two horizontal straps.

Position the flue template on the wall, the arrow points on the centres of the two upper fixing points previously marked, see diagram 6.4 which also shows dimensions.

For rear flue, mark the rear flue position as required, centre and/or diameter.

For a side flue, mark the horizontal flue centre line at the sides of the template. Extend the flue centre line horizontally left or right to the internal corner where the flue is required to exit to outside. Mark the position of the circular hole, on the flue exit wall, using the dimensions given in diagram 6.5.

From the flue position marks, check that the flue terminal will be in a suitable position, see diagram 3.6.

6.3 Flue Hole Cutting

Cut the hole horizontally in the wall, to the diameter shown in diagram 6.4, using, preferably, a core drill.

After cutting the hole, check that it will accept the wall sleeve.

6.4 Wall Sleeve

Note: The wall sleeve should be used for all installations.

Place the wall sleeve into the hole, flush with the outside wall face and seal around the sleeve to make it weatherproof on the outside and internally "good". Access to the outside is possible through the sleeve. If the sleeve is too long, cut it to the same length as the wall thickness.

For wall thicknesses over 300mm, the wall sleeve must be fitted flush with the outside wall face. Make good the external wall face, leave the internal wall face till later.

6.5 Boiler Mounting Frame Fixing

Position the flue template over the flue hole and check the position of the wall fixing points. Mark the position of the fixing holes again, if required.

Drill the four fixing holes and insert wall plugs to suit No.10x50mm long screws.

Secure the boiler mounting frame to the wall using No.10x50mm long screws.

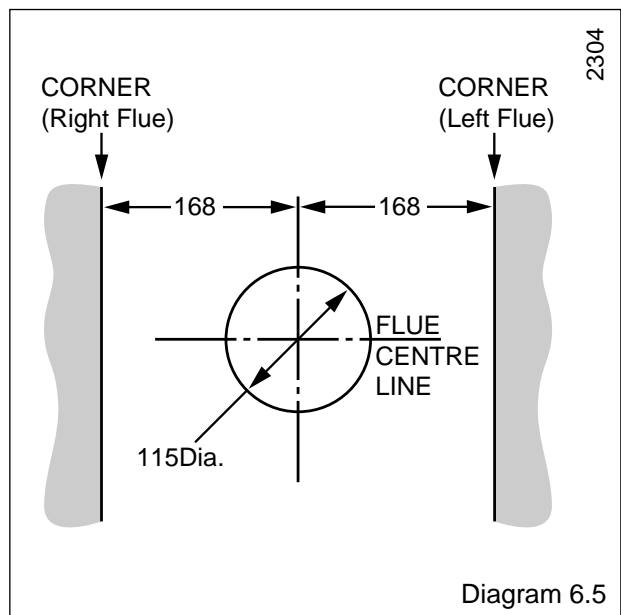
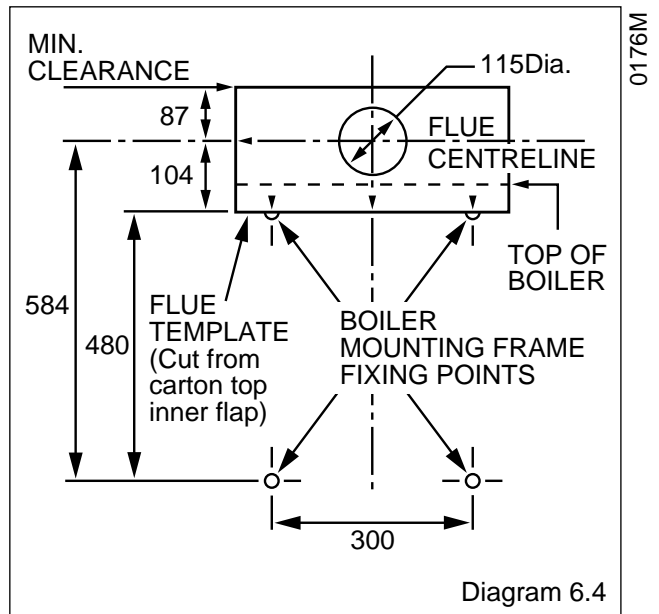

7.1 Flue Length

For a rear flue, measure the distance from the outside wall face to the boiler mounting wall. Check that the flue length will be suitable, see diagram 3.1 for a standard flue system or diagram 3.3 for a 1, 2 or 3 metre flue system.

For a side flue, measure the distance from the outside wall face to the side of the boiler mounting frame. Check that the flue length will be suitable, see diagram 3.2 for a standard flue system or diagram 3.4 for a 1, 2 or 3 metre flue system.

All flue systems are installed in a similar manner to the standard flue.

Note: For all 1, 2 or 3 metre flues make sure that the flue duct is cut at the opposite end to the fixed spacer.

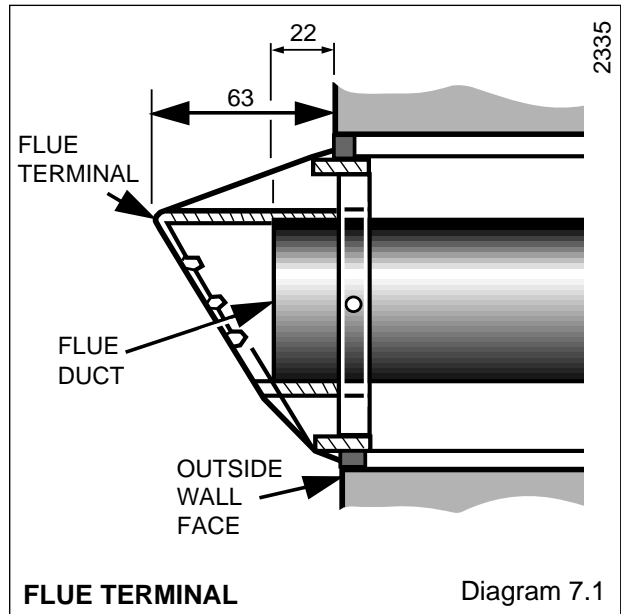

7.2 Rear Flue

Mark the air duct assembly and the flue duct at the lengths shown in diagram 7.1 and 7.2, then cut to length, cutting square and removing any burrs.

7.3 Side Flue

Mark the air duct assembly and the flue duct at the lengths shown in diagram 7.1 and 7.3 then cut to length, cutting square and removing any burrs.

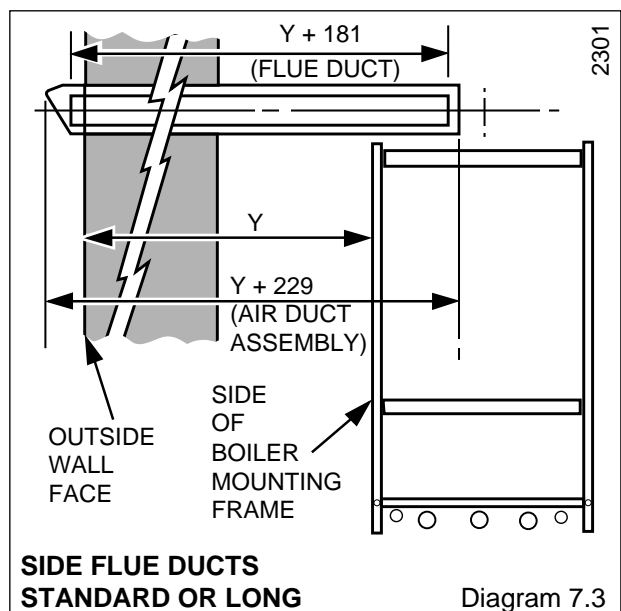
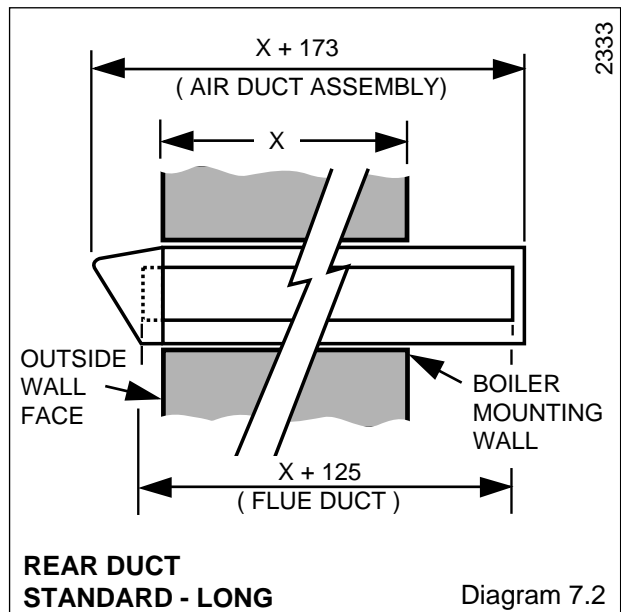

7 Flue Preparation

7.4 Air Duct

Locate the flue duct and air duct in the flue elbow, making sure that the flue duct is located in the flue terminal and the flue elbow but is free to move to allow for expansion.

Check that the flue terminal is in the correct position and sticking out the correct distance from the outside wall face, see diagram 7.1 and appropriate diagram 7.2 or 7.3.

Drill a hole, diameter as shown in diagram 7.4, in each side of the air duct, through the holes in the flue elbow. Secure the air duct to the flue elbow using the two screws supplied in the loose items pack.

Seal around the joint between the air duct and the flue elbow using the tape provided in the loose items pack.

Stick the self-adhesive seal, supplied in the loose items pack, around the air duct, in a position so that it will be flush with the outside wall when installed, see diagram 7.5.

If the boiler is not to be fitted for some time, cover the hole in the wall.

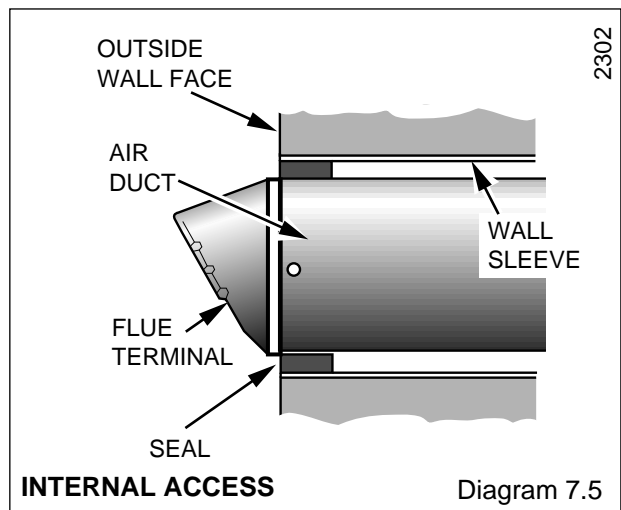
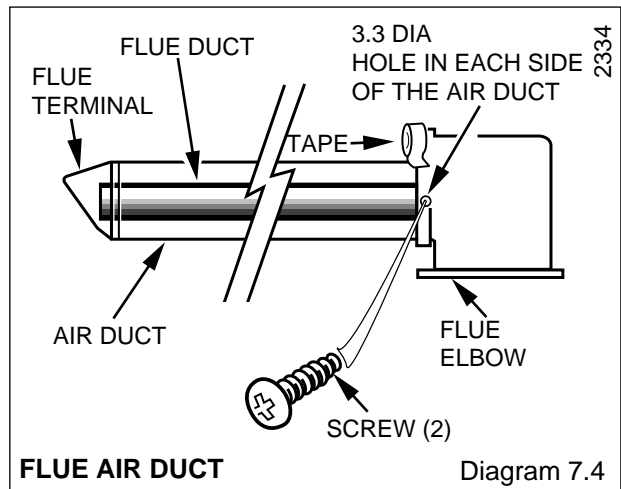

8.1 Gas Connection

Provision is made for the gas supply to be connected from below or through the wall at the rear of the boiler, see diagram 8.1 for position.

Refer also to “Gas Supply”, Section 1.7.

Make the gas supply connection to the gas service cock. Slacken or remove the clip, as preferred, while making the connection. Do not subject the gas service cock to heat as you may damage the seals.

8.2 Water Connections

Provision is made for the domestic cold water inlet to be connected from below or through an internal wall at the rear of the boiler, see diagram 8.1 for position. Refer also to Section 5 “Domestic Hot Water System”.

Provision is made for the domestic hot outlet, heating flow and return to be connected from below, through an internal wall at the rear of the boiler or from above, passing down either side of the boiler, see diagram 8.2 for clearances. Take care that any pipework connected from above, within the boiler mounting frame will clear the expansion vessels.

If necessary, temporarily fit the boiler, refer to Section 10.1, “Mounting the Boiler”.

Flush out the domestic water and heating system before connecting the boiler.

Make the connections to the domestic hot water outlet and the heating system by means of the isolating valves, see diagram 8.1.

Slacken or remove the clips, as preferred, while making the connections. Do not subject any of the isolating valves to heat as you may damage the seals.

Make sure that the drain points on the isolating valves are positioned towards the front of the boiler, also that the drain and operating screw heads are accessible.

8.3 Safety Valve Discharge

WARNING. It must not discharge above an entrance or window or any type of public access area.

A short discharge pipe is supplied loose with the boiler, which when fitted to the safety valve, will end below the boiler at the mark between the cold water inlet and the heating flow, for position and dimension see diagram 8.1.

This must be extended, using not less than 15mm od pipe, to discharge, in a visible position, outside the building, facing downwards, preferably over a drain. The pipe must have a continuous fall and be routed to a position so that any discharge of water, possibly boiling, or steam cannot create any danger to persons, damage to property or external electrical components and wiring.

Note. To ease future servicing it is advisable to use a compression type fitting to extend the discharge pipe.

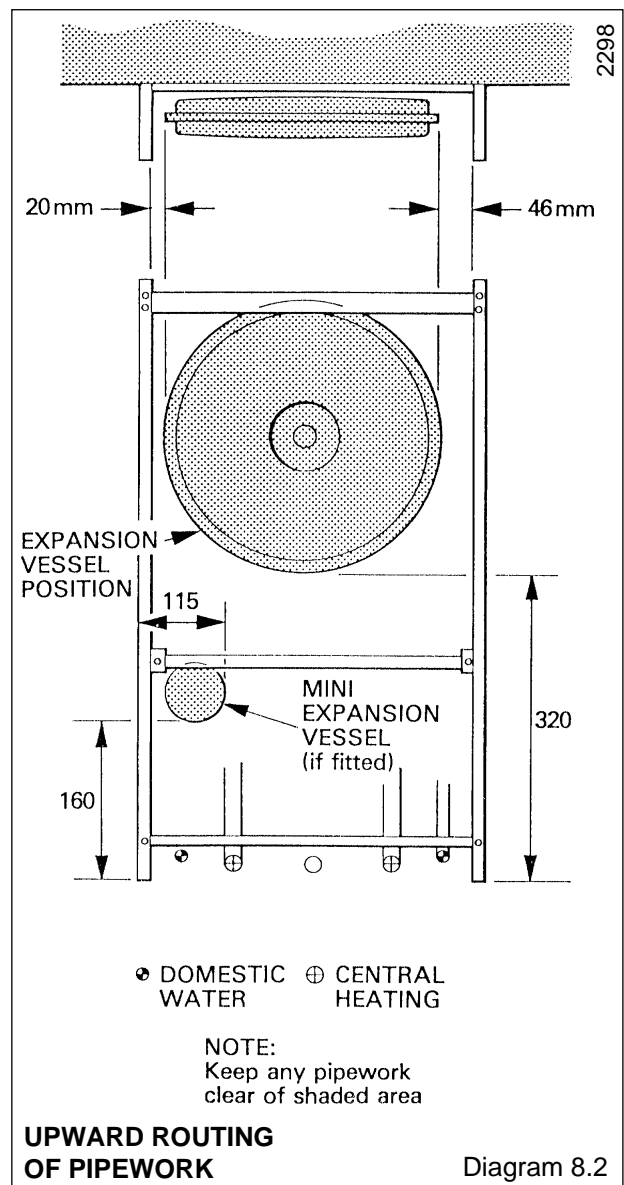
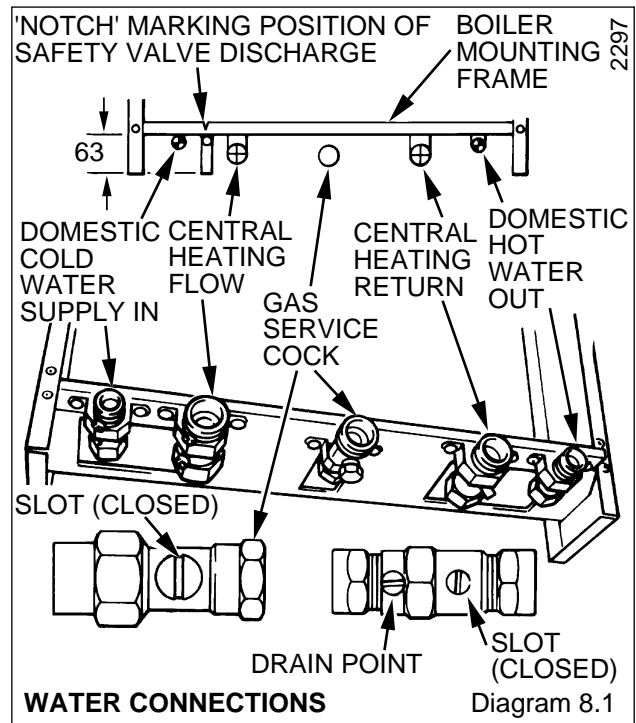

9.1 Supply Cable Connection

CAUTION: To prevent an induced current from switching the central heating on, when not required, it is important that the heating system control cables are separated from the other mains supply cables.

The boiler requires a permanent mains supply through an external isolator which must also isolate any heating system controls, see diagram 9.1.

Any heating system controls must not interrupt the permanent mains supply to the boiler.

Remove the electrical connector from the loose items pack.

Remove the two screws and cover from the connector, see diagram 9.2.

Using PVC cable of a suitable length and rating as stated in Section 1.8 “Electrical Supply”, connect the mains supply cable to the appropriate terminals of the connector, see diagram 9.1.

Standard colours are, Brown - Live, Blue - Neutral, Green and Yellow - Earth.

The mains cable outer insulation must not be cut back external to the plug, see diagram 9.2.

Make the earth cable of a greater length so that if the cable is strained the earth would be the last to become disconnected.

CAUTION: It is **ESSENTIAL** to make sure that the polarity is correct.

9.2 Heating System Controls

CAUTION: To prevent an induced current from switching the central heating on, when not required, it is important that the heating system control cables are separated from the other mains supply cables.

It is recommended that the heating system is controlled by a time switch and a room thermostat, or alternatively by thermostatic radiator valves.

If electrical controls are not to be used to regulate the heating system, do not disturb the red link cable.

If any form of electrical control is being used to regulate the heating system, remove the red link cable and connect heating system controls in series.

The mains cable outer insulation must not be cut back external to the plug.

9.3 Clock/Timer Kit

An internal clock/timer kit can be supplied, refer to the literature supplied with the kit.

9.4 Frost Thermostat

If the installation requires protection by a “frost thermostat”, connect a single pole type, to the appropriate terminals of the connector.

9.5 Cable and Connector Securing

After completing all the connections to the boiler, secure the cable(s) with the cover, using the two screws previously removed, see diagram 9.2.

Clip the connector into position with the cable(s) at the back.

Secure all cables in the clamp immediately behind the connector.

If necessary also secure cables to the wall, using suitable cable clips.

Keep all cables away from hot surfaces.

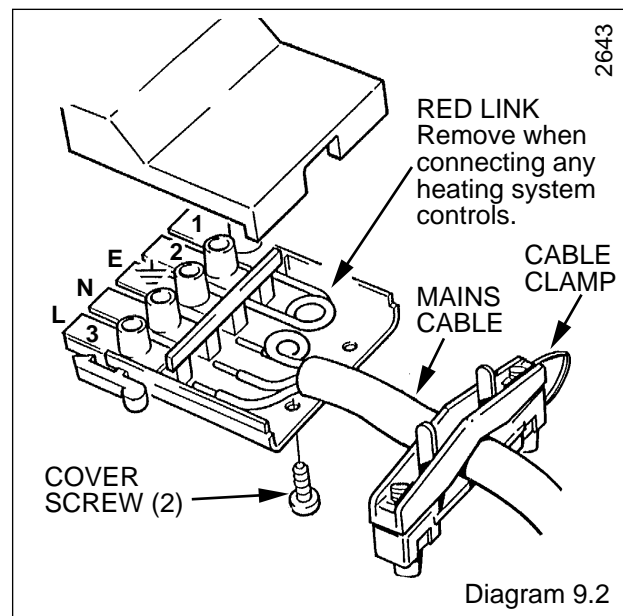

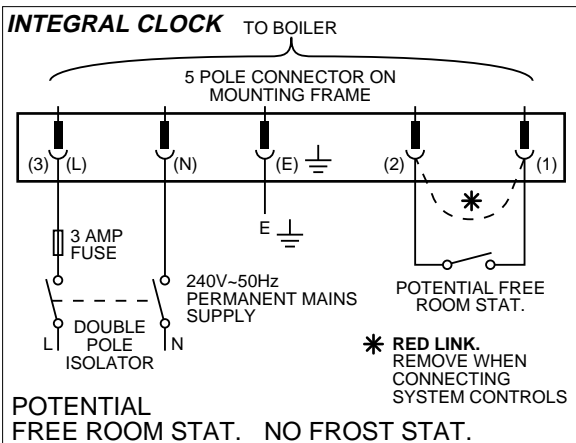
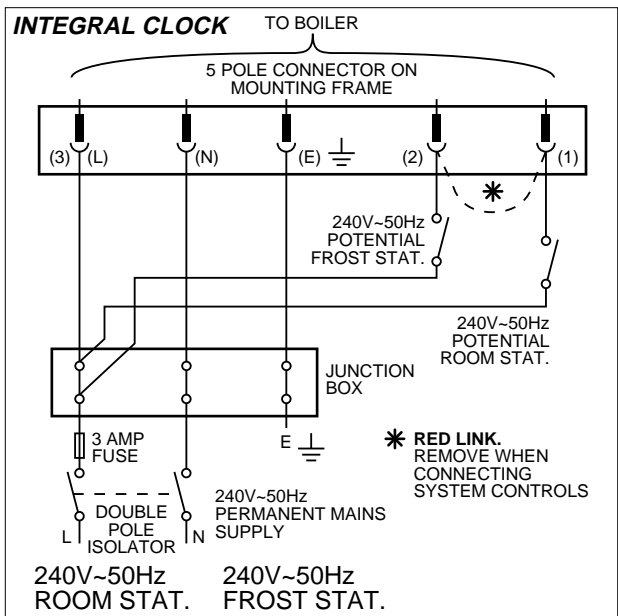
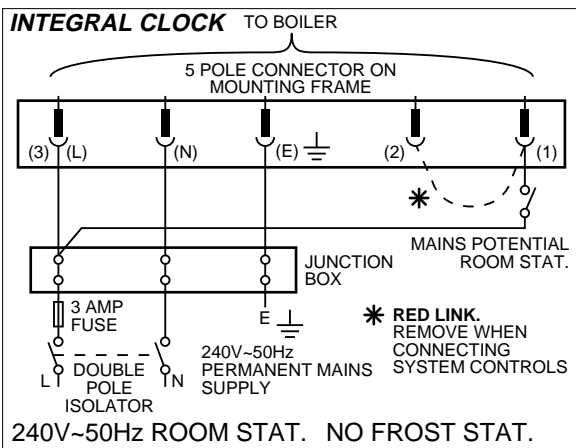
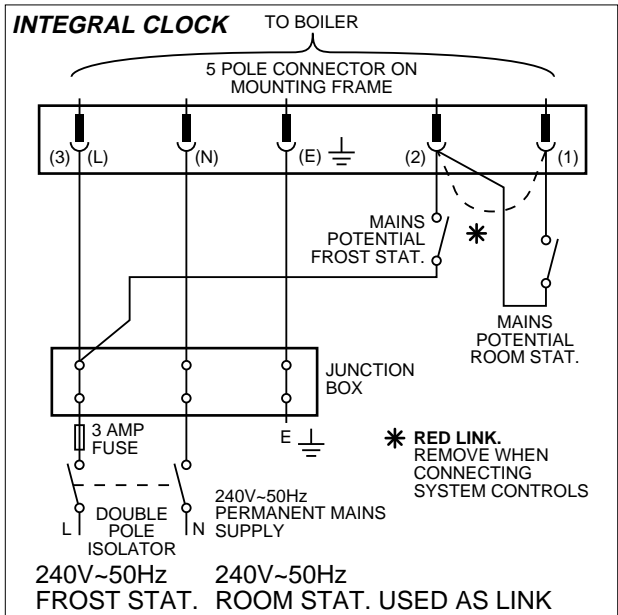
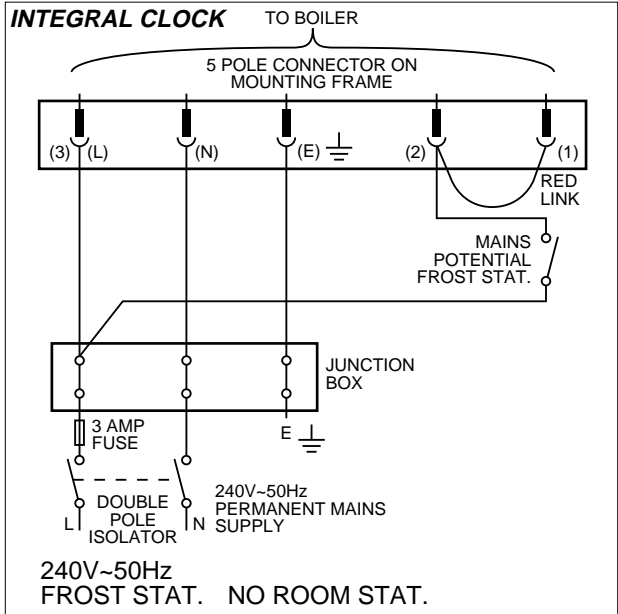
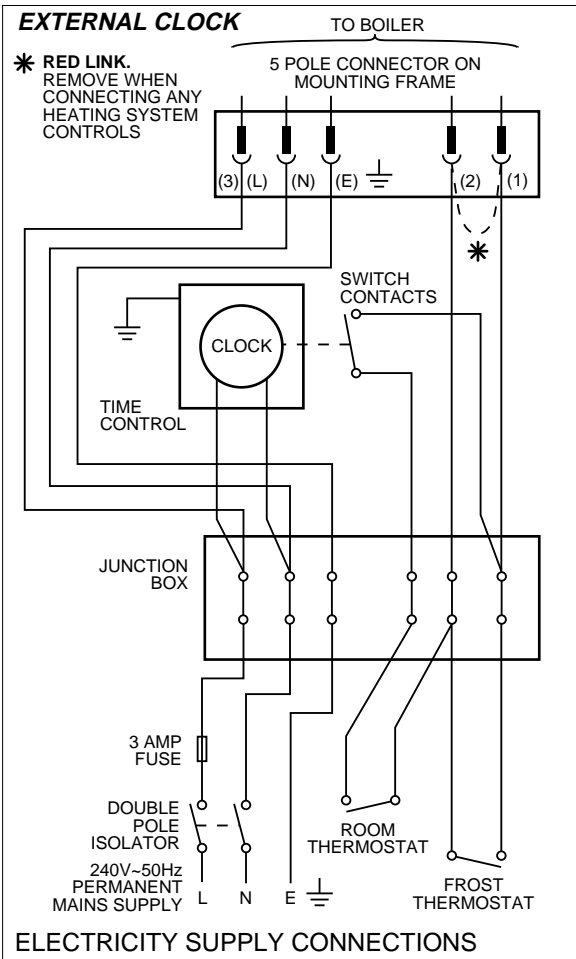

Diagram 9.1

10.1 Mounting the Boiler

After installing the boiler mounting frame, domestic and heating water systems, making the electrical connections and preparing the flue components, carry on as below:

Lift the boiler into position, hooking it on the boiler mounting frame at the top, then loosely fit the two boiler securing screws at the top, see diagram 6.3.

10.2 Gas and Water Connections

Locate the boiler water pipes into the isolation valves and the gas service cock union halves. Fully push the boiler back to the mounting frame, locating the studs into the clips.

Make the compression joint on the isolating valves and join the gas service cock union. Secure all of the valves and gas service cock with the clips.

10.3 Boiler Securing

Secure the boiler by tightening the two boiler securing screws at the top.

10.4 Discharge Pipe

Remove the two control housing securing screws, see diagram 10.1.

Remove the control housing and support the control housing on a surface or by screwing it to the front edge of the base, using one of the securing screws, see diagram 10.1.

Fit the short discharge pipe to the safety valve using the nut and olive supplied loose, see diagram 10.2.

Extend the discharge pipe, using only a compression type fitting to join the discharge extension, refer also to Section 8.3 "Safety Valve Discharge".

10.5 Clock/timer Kit (if applicable)

Fit the clock/timer kit following the appropriate sections of the instructions supplied with the kit.

10.6 Electrical Connector

Connect the two halves of the electrical connector together.

Clip the connector into position on the boiler mounting frame. Secure the cables with cable clamp immediately behind the connector.

Carryout preliminary electrical system checks as below:

1. Test insulation resistance to earth of mains cables.
2. Test earth continuity and short circuit of all cables
3. Test the polarity of the mains.

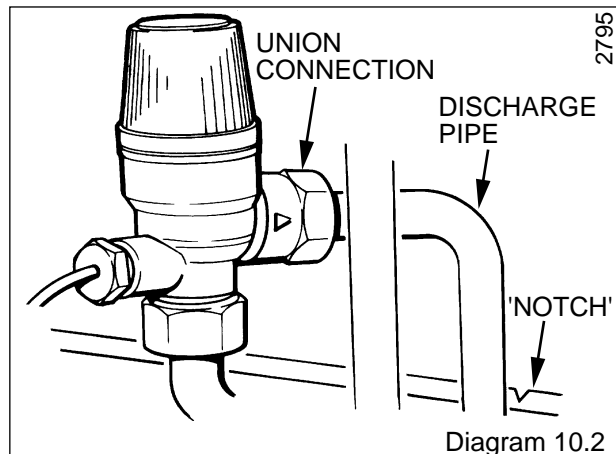
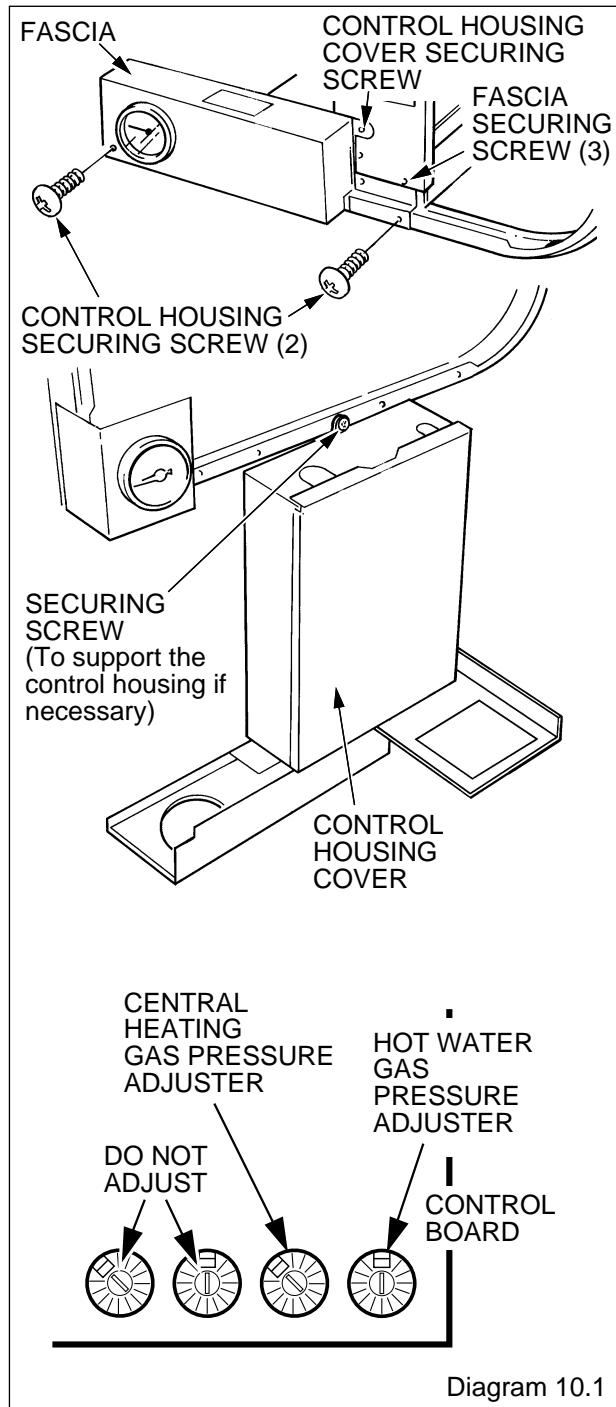

10.2 Flue Fixing

Fit the self-adhesive gasket, supplied in the loose items pack, to the flue elbow, see diagram 10.3.

Push the prepared ductings into and through the wall sleeve, the longest protrusion of the flue terminal is positioned at the top.

Note: The foam seal is a tight fit in the wall sleeve and the flue system should not be inserted unless the cement has fully set or it can be held from the other side.

Fit the flue elbow to the top of the boiler, see diagram 10.6, using the four screws supplied loose. To assist with the location of the flue elbow into the fan outlet, loosen the two wing nuts on the flue collector angle and the two fan securing screws.

Tighten the four screws of the flue elbow evenly to ensure a good seal at the gasket. Tighten the wing nuts and screws, if slackened, to secure the flue collector and fan.

Make the wall good internally around the air duct.

Check that the ductings do not slope down towards the boiler.

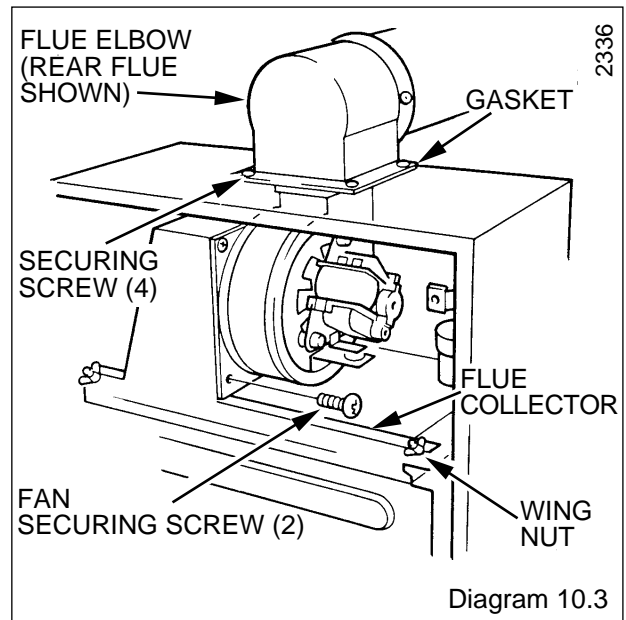

11.1 Filling Domestic Water Circuit

Check that the boiler is isolated from the electrical supply, at the external isolator.

Fully open the domestic water supply stop cock or valve in the supply to the boiler.

Open the two domestic water isolation valves, slots in line with the length of the valve, see diagram 8.1.

Open all hot water draw-off taps and close them when water flows. Check for water soundness of the whole domestic water system and boiler.

11.2 Filling the Heating System

It is essential that a bypass is fitted in all installations, 22mm o.d. minimum. The bypass must have a lockable valves "B" in diagram 4.2, incorporated in a position so that inadvertent closure or unauthorised interference is not possible.

The bypass **MUST** be fitted before any system control. A radiator bypass is not recommended.

Open the two central heating isolating valves, slots in line with the length of the valve, see diagram 8.1.

Flush, fill and vent the system refer to Section 4.9 "Filling Sealed Systems".

WARNING. SEVERAL COMPONENTS OPERATE ON MAINS VOLTAGE AND WITH THE OUTER CASE REMOVED, LIVE COMPONENTS BECOME EXPOSED.

To assist in filling and venting, the pump may be operated: Connect the electrical supply, set switch "C" to "On", white flash showing, any remote heating systems controls, time switch and/or room thermostat to call for heat, see diagram 11.1.

Note. If the clock/timer kit is to be fitted, refer to the setting instructions in the Instructions for Use.

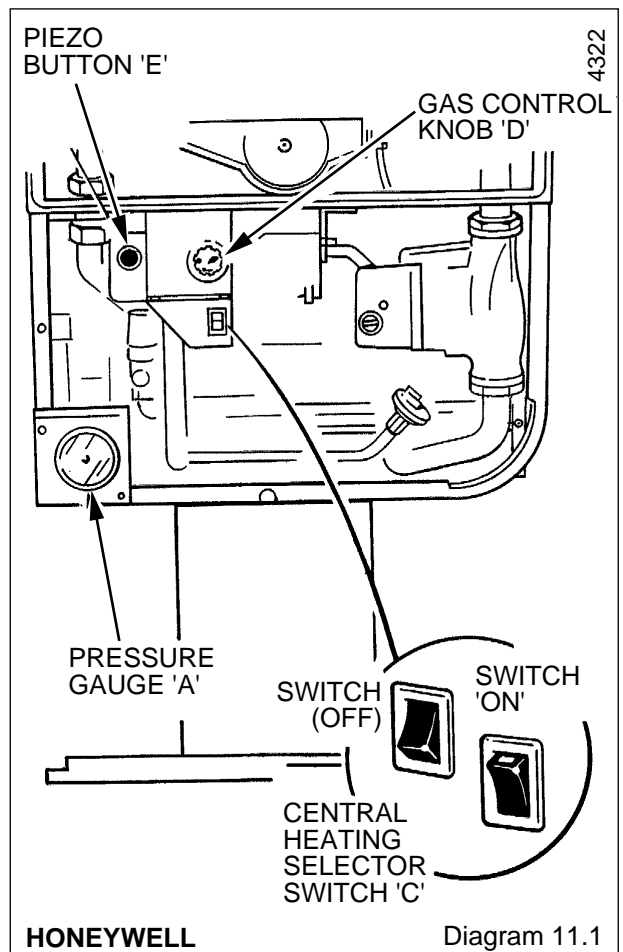
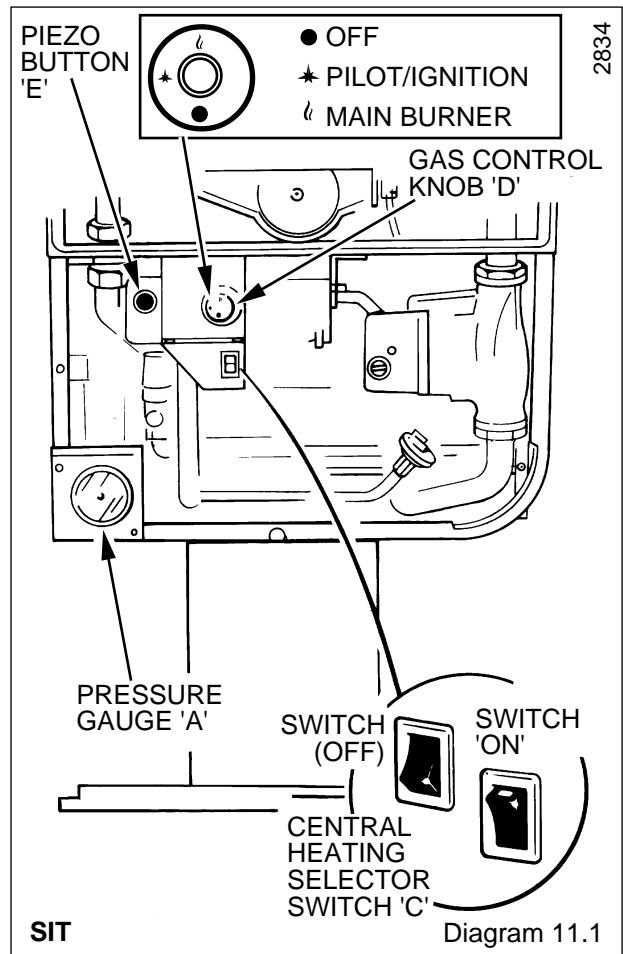

Make sure that the automatic air vent is operating correctly, see diagram 11.2.

Take care not to splash any of the electrical components.

Alternate the position of switch "C" between "On" and "Off" positions to ensure that water flows through all parts of the boiler and air is not trapped in the boiler internal bypass.

Pressurise the system until the pressure is 1.5bar (21.5lbf/in²). Check the heating system and boiler for water soundness.

Check the operation of the safety valve by turning the safety valve knob in the direction of the arrow.

Lower the pressure to the initial cold fill design pressure, refer to Section 1.6 "Data". Position the set pointer on the boiler pressure gauge at this pressure also.

11.3 Preparation for Lighting

Isolate the boiler from the mains electrical supply at the external isolator.

Test for soundness and purge air from the gas supply. Turn on the gas service cock, slot in line with the length of the cock.

SIT only - Slacken the two piezo unit bracket screws and remove the bracket, keyhole slot.

Slacken the burner pressure test point screw and connect a suitable pressure gauge, see diagram 11.3.

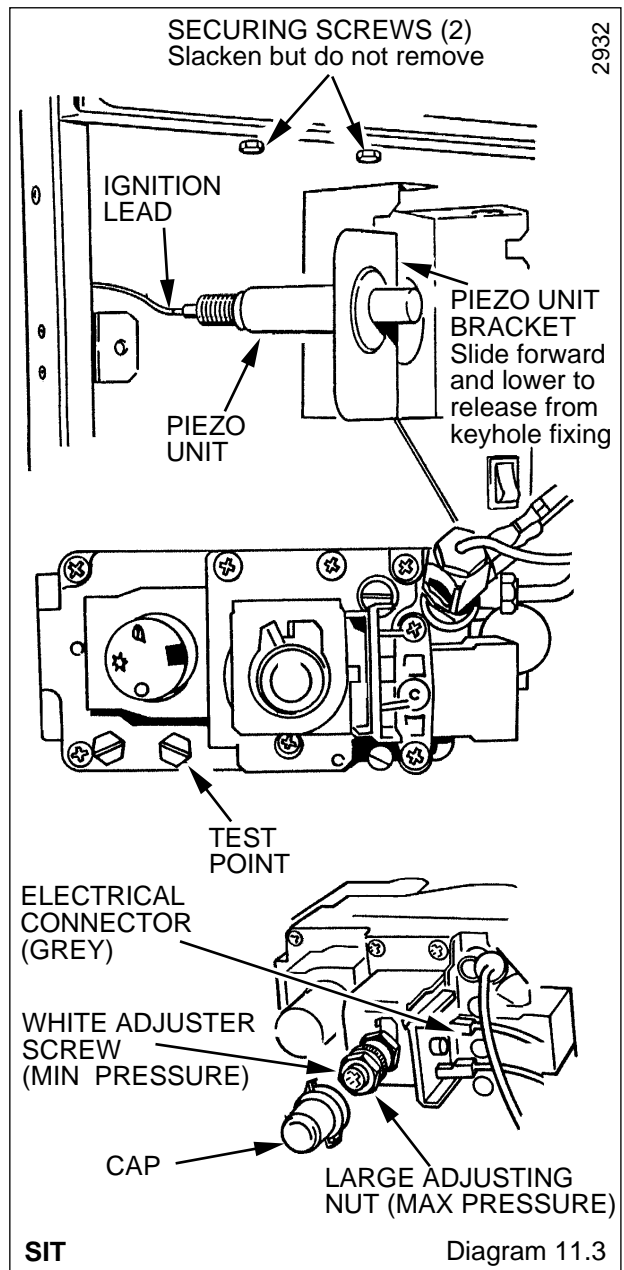
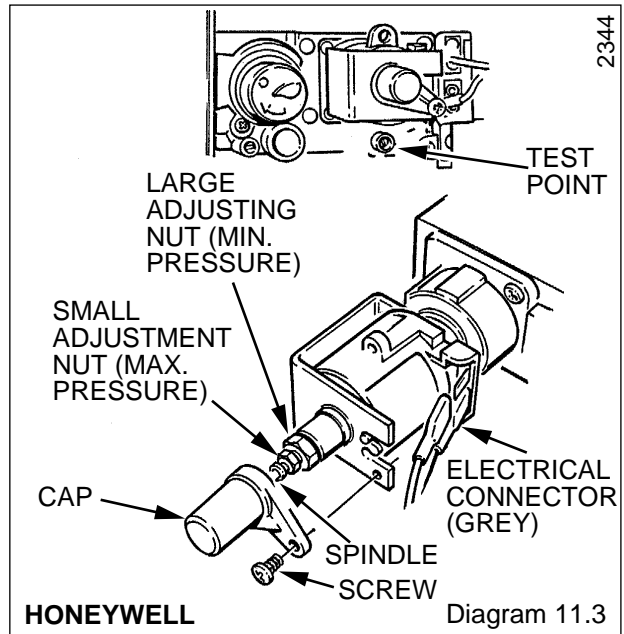
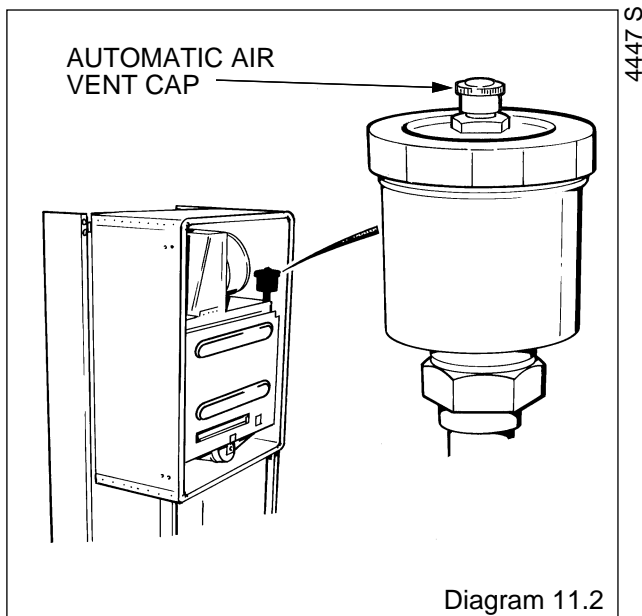

11.4 Initial Lighting of Pilot - Honeywell

Identify the boiler controls, see diagram 11.1.

Check that the boiler is isolated from the electrical supply at the external isolator.

Fully depress and hold in gas control knob “D”. Press and release piezo button “E” until the pilot burner lights, (at this stage, air may be present in the gas components of the boiler, therefore this operation may need to be repeated). When the pilot flame has lit and is stable, keep knob “D” fully depressed for 15 seconds, then release. The pilot burner should then remain alight.

If the pilot flame goes out now or at any time, a safety device prevents immediate relighting. Wait 4 minutes before attempting to relight.

If the pilot burner goes out on releasing knob “D”, repeat the above lighting sequence but this time keep knob “D” depressed for a little longer.

The pilot flame size is preset and should envelop the thermocouple, the approximate flame size is shown in diagram 11.4. If the flame size is incorrect refer to the adjusting instructions in “Pilot Burner” in “Replacement of Parts” section of the Servicing Instructions.

Check for gas soundness of the pilot supply using leak detection fluid. Take care not to splash any of the electrical components.

Test the operation of the thermocouple flame failure system to ensure the boiler shuts down within 60 seconds, indicated by a “click” from the gas valve.

If the pilot burner will not stay alight, refer to “Thermocouple and Overheat Cutoff” in “Fault Finding” section of the Servicing Instructions.

Fit the cover of the inner case, making sure that it is fitted and seals correctly, using the four screws previously removed, see diagram 6.2.

Make sure that all hot water draw off taps are closed then set switch “C” to “Off” as shown in diagram 11.1.

With the boiler isolated from the electrical supply the pilot flame may go out. If this should happen, wait 4 minutes then relight the pilot burner following the above lighting instructions but with the electrical supply connected.

11.4 Initial Lighting of Pilot - SIT

Identify the boiler controls, see diagram 11.1.

Check that the boiler is isolated from the electrical supply at the external isolator.

Turn gas control knob “D” to ★ pilot/ignition position and depress. Press and release piezo button “E” until the pilot burner lights, at this stage air may be present in the gas components, so the operation may need repeating. When the pilot flame has lit and is stable, keep knob “D” fully depressed for about 15 seconds and then release. The pilot burner should stay alight.

If the pilot flame goes out now or at any time, a safety device prevents immediate relighting. Wait 4 minutes before attempting to relight.

If the pilot goes out on releasing knob “D” repeat the lighting instructions but now keep knob “D” depressed for a little longer after the pilot has lit.

If the pilot burner will not stay alight, refer to “Thermocouple and Overheat Cutoff” in Fault Finding section of the Servicing Instructions.

The pilot flame size is factory preset and should envelop the thermocouple to about the size given in diagram 11.4. If the flame size is incorrect, refer to “Pilot Burner” in Servicing Instructions.

Check for soundness of the pilot supply using a suitable leak detection fluid.

Test the operation of the flame supervision system by turning knob “D” clockwise to “●” position to make sure that it shuts down within 60 seconds, indicated by a click from the valve.

Fit the cover of the inner case, making sure that it is fitted and seals correctly, using the four screws previously removed, see diagram 6.2.

Make sure that all hot water draw off taps are closed then set switch “C” to “Off” as shown in diagram 11.1.

With the boiler isolated from the electrical supply the pilot flame may go out. If this should happen, wait 4 minutes then relight the pilot burner following the above instructions but with the electrical supply connected.

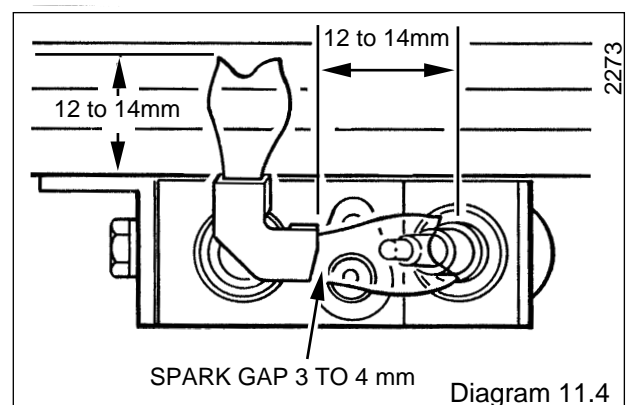

11.5 Burner Pressure - Hot Water - Honeywell

The burner pressure is factory preset and no adjustment should be required.

Connect the electrical supply; the pump and fan will operate for about 30 seconds, then the fan will reduce speed and the pump stop.

Relight the pilot burner.

Fully open the largest hot water draw off tap whereby the main burner will light, the flames gradually increasing to the maximum.

Check the soundness of the boiler gas joints, with the main burner on, using a leak detection fluid. Take care not to splash any of the electrical components.

Fully open the hot water throttle, (clockwise), see diagram 11.5. Check that the water flow rate is not less than 9Litre/min. (2.0gall/min) to prevent any modulation of the gas pressure. This is equivalent to 6.7 seconds to fill a 1Litre container (3.8 seconds for 1pint).

To achieve this flow rate a water pressure of at least 0.8bar is required during commissioning, although subsequently the appliance will work at a minimum pressure of 0.5bar.

This flow rate should prevent any modulation of the gas pressure.

Check the burner pressure is within +/-0.35mbar (+/- 0.14in wg). of 15.7mbar (6.3in wg), the hot water burner pressure. If this is incorrect, the burner pressure may be adjusted to the correct setting by turning the hot water gas pressure adjuster (potentiometer), using an insulated screwdriver, see diagram 10.1. Gain access to the adjusters on the control board by removing the control housing cover, see diagram 10.1. Turn the adjuster slowly, always making adjustment by reducing below the required pressure then increasing up to the required setting, (turn clockwise to increase).

Close the hot water draw off.

If the maximum pressure cannot be obtained, check that the gas supply of adequate size, refer to Section 1.8.

11.5 Burner Pressure - Hot Water - SIT

The burner pressure is factory preset and no adjustment should be required.

Connect the electrical supply.

Relight the pilot.

Turn gas control knob "D" to "4", main burner position.

Fully open the largest hot water draw off tap whereby the main burner will light, the flames gradually increasing to the maximum.

Check the soundness of the boiler gas joints, with the burner lit, using a suitable leak detection fluid. Take care not to splash any of the electrical components.

Fully open the hot water throttle, (clockwise), see diagram 11.5. Check that the water flow rate is not less than 9Litre/min (2.0gall/min) to prevent any modulation of the gas pressure. This is equivalent to 6.7 seconds to fill a 1Litre container (3.8 seconds for 1pint).

To achieve this flow rate a water pressure of at least 0.8bar is required during commissioning, although subsequently the appliance will work at a minimum pressure of 0.5bar.

This flow rate should prevent any modulation of the gas pressure.

Check that the burner pressure is 16.1mbar +/- 0.35mbar (6.5in wg +/- 0.14wg) If this is incorrect, the burner pressure may be adjusted by turning the larger brass adjusting nut of the modulator, anti-clockwise to decrease, after removing the cap, see diagram 11.2.

Fine adjustment may be achieved by turning the hot water gas pressure adjuster (potentiometer), using an insulated screwdriver, see diagram 10.1. Gain access to the adjusters on the control board by removing the control housing, see diagram 10.1.

Turn the adjuster slowly, always making adjustments by reducing below the required pressure then increasing up to the required setting, turn clockwise to increase.

Close the hot water draw off.

If the maximum pressure cannot be obtained, check that the gas supply is of adequate size, refer to Section 1.7.

11.6 Gas Rate Modulation - Honeywell

The minimum gas rate is factory preset and no adjustment should be required.

ALWAYS CHECK HOT WATER BURNER PRESSURE FIRST - REFER TO SECTION 11.5.

To check the minimum gas rate, first make sure that the boiler is isolated from the electrical supply at the external isolator. Disconnect one of the electrical connectors (grey), from the modulator, see diagram 11.3.

Insulate the connector to make sure that it does not contact any metallic part of the boiler.

Switch on the electrical supply.

Fully open a hot water draw off tap and the main burner will light at the minimum gas rate.

Check that the burner pressure is 2.9mbar +/-0.2mbar, (1.2in wg +/-0.1in wg). If this is incorrect, it may be adjusted by removing the cap and turning the larger adjusting nut of the modulator, (anti-clockwise to decrease the pressure).

If the above adjustment was necessary, it will be essential to check that the maximum pressure can still be obtained. Push the spindle gently in to the stop and hold it in. The maximum pressure should not be less than 16.1mbar, (6.5in wg). If this pressure cannot be achieved, obtain it by turning the small adjusting nut, (clockwise to increase the pressure). Always adjust the minimum pressure first.

If the maximum pressure is unattainable, check that the gas supply is of adequate size, refer to Section 1.7 "Gas Supply". Put right as necessary.

Isolate the boiler from the electrical supply then reconnect the modulator cable and refit the cap.

Isolate the boiler from the electrical supply then reconnect the modulator cable and refit the cap.

11.6 Gas Rate Modulation - SIT

The minimum gas rate is factory preset and no adjustment and should be required.

ALWAYS CHECK HOT WATER BURNER PRESSURE FIRST - REFER TO SECTION 11.5.

To check the minimum gas rate, first make sure that the boiler is isolated from the electrical supply at the external isolator. Disconnect one of the electrical connectors, grey, from the modulator, see diagram 11.3.

Insulate the connector to make sure it does not contact any metallic parts.

Switch on the electrical supply.

Fully open a hot water draw off tap and the main burner will light at the minimum gas rate.

Check that the burner pressure is 2.9mbar +/- 0.2mbar (1.2in wg +/-0.1in wg). If this is incorrect, it may be adjusted by turning the centre white adjuster screw of the modulator, anti-clockwise to decrease, whilst at the same time stopping the larger brass nut from turning, see diagram 11.3.

Isolate the boiler from the electrical supply then reconnect the modulator cable and refit the cap.

11.7 Domestic Water Flow Rate

Adjust the water throttle to obtain a flow rate of 9Litre/min (2gall/min), (clockwise to increase), see diagram 11.5. This is equal to 7 seconds to fill a 1Litre container (4seconds to fill a 1pint container). Close the tap when adjustment is satisfactory.

The minimum water flow rate is 3.6Litre/min (0.8gall/min) equivalent to 16.5 seconds to fill a 1Litre container (9.5 seconds to fill a 1pint container). If this flow rate cannot be achieved, check that there is no partial blockage and that the supply is of adequate size. Put right as necessary.

Close the hot water draw off tap.

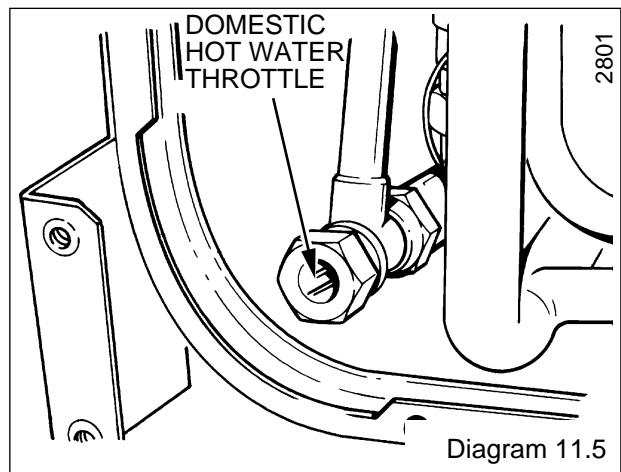

11.8 Burner Pressure - Heating

The burner pressure is factory preset and no adjustment should be required.

Check that all remote heating system controls, room thermostats, integral clock and the like are switched on/programmed and calling for heat.

Set switch "C" to "On" as shown in diagram 11.1.

The pump will circulate water through the boiler and the main burner will light.

Check that the burner pressure, with the heating system cold to prevent any modulation of the gas pressure, is within +/-0.2mbar (+/-0.08in wg) of 8.8mbar (3.5in wg), SIT and 9mbar (3.6in wg), Honeywell, the central heating pressure. If the burner pressure is incorrect, it may be adjusted to the correct setting by turning the central heating gas pressure adjuster (potentiometer), using an insulated screwdriver, see diagram 10.1. Turn the adjuster slowly, always making adjustment by reducing below the required pressure then increasing up to the required setting, (turn clockwise to increase).

Isolate the boiler from the electrical supply.

Remove the pressure gauge and tighten the test point screw.

Note. It will be necessary when finally mounting the clock to reposition the gas valve solenoid and thermocouple lead.

Fit the cover and secure the control housing with the screws previously removed.

Test for gas soundness around the burner pressure test point with the main burner alight, using leak detection fluid. Take care not to splash any of electrical components.

SIT only - Refit the piezo bracket.

11.9 Temperature Settings

The domestic hot water outlet and central heating flow temperatures are factory preset and sealed, therefore cannot be adjusted.

The nominal temperature setting for the domestic hot water outlet is 60°C (140°F) at a flow rate of 3.6Litre/min (0.8gall/min).

The nominal maximum flow temperature setting for central heating is 82°C (180°F).

11.10 Heating System - Commissioning

Check that all remote controls and integral clock are calling for heat.

Fully open all radiator valves, flow control valve "A" and bypass valve "B", see diagram 4.2.

Set the heating system in operation and balance the radiators.

Adjust the control valve "A" to achieve the required system differential temperature between the flow and return.

Turn off all radiators, then adjust bypass valve "B" to achieve the same temperature difference between the boiler flow and return.

Refer to Section 4.6 and diagram 4.1/4.1A.

Allow the system to reach maximum temperature then switch off, isolate the boiler from the electrical supply and drain the system rapidly whilst still hot.

Fill and vent the system as described in Section 11.2 "Filling the Central Heating Circuit". Add inhibitor, if applicable, refer to Section 4.10 "Inhibitor".

Lower the pressure to the initial cold fill design pressure, using the external draining tap, close to the boiler, refer to Section 4.11.

Lock or remove the handles from the spindles of flow control valve "A" and bypass valve "B" to prevent unauthorised adjustment.

The permanent mains electrical supply to the boiler must not be switched off whilst the pilot flame is alight.

11.11 Completion

The user control door is designed for left or right hand hinging. If required the hinge can be moved to the other side to that supplied, as follows:

Remove the hinge pin bracket securing screw then remove the hinge pin retaining bracket and holding the door, remove the hinge pin. Prise out the hinge pin bushes and fit on to the opposite side of the door, see diagram 11.6.

Remove the screw and nut and fit to the opposite side of the case. After removing the hinge pin retaining bracket refit the door and hinge pin. Refit the hinge pin retaining bracket and fit the securing screw.

Fit the catch assembly, supplied in the loose items pack, see diagram 11.6.

If required, fit the plastic covers to hide the bracket securing screws.

Change the position of the "Push" label to suit the new door opening.

Clock/timer, if fitted, remove the plastic retaining plugs to release the coverplate. Fit the new plastic plugs, from the loose items pack, see diagram 11.6.

Stick the casing label to the right hand side of the clock/timer.

Fit the outer case, secure with the screws, see diagram 6.1.

Set the boiler and any remote heating control to the desired settings, then close the door.

11.12 Instruct the User

Instruct and demonstrate the lighting procedure, then advise the user of the efficient and safe operation of the boiler.

Instruct and demonstrate the operation of any heating system controls.

Advise the user on the use and maintenance of any scale reducer and pass on any relevant instructional documents.

Advise the user that to ensure the continued efficient and safe operation of the appliance it is recommended that it is checked and serviced at regular intervals. The frequency of servicing will depend upon the particular installation and usage, but in general once a year should be enough.

Advise the user of the precautions necessary to prevent damage to the system and building in the event of the heating system being out of use during frost and freezing conditions.

Advise the user that the permanent mains electrical supply must not be switched off whilst the pilot is alight.

Reminder - Leave these instructions with the user.

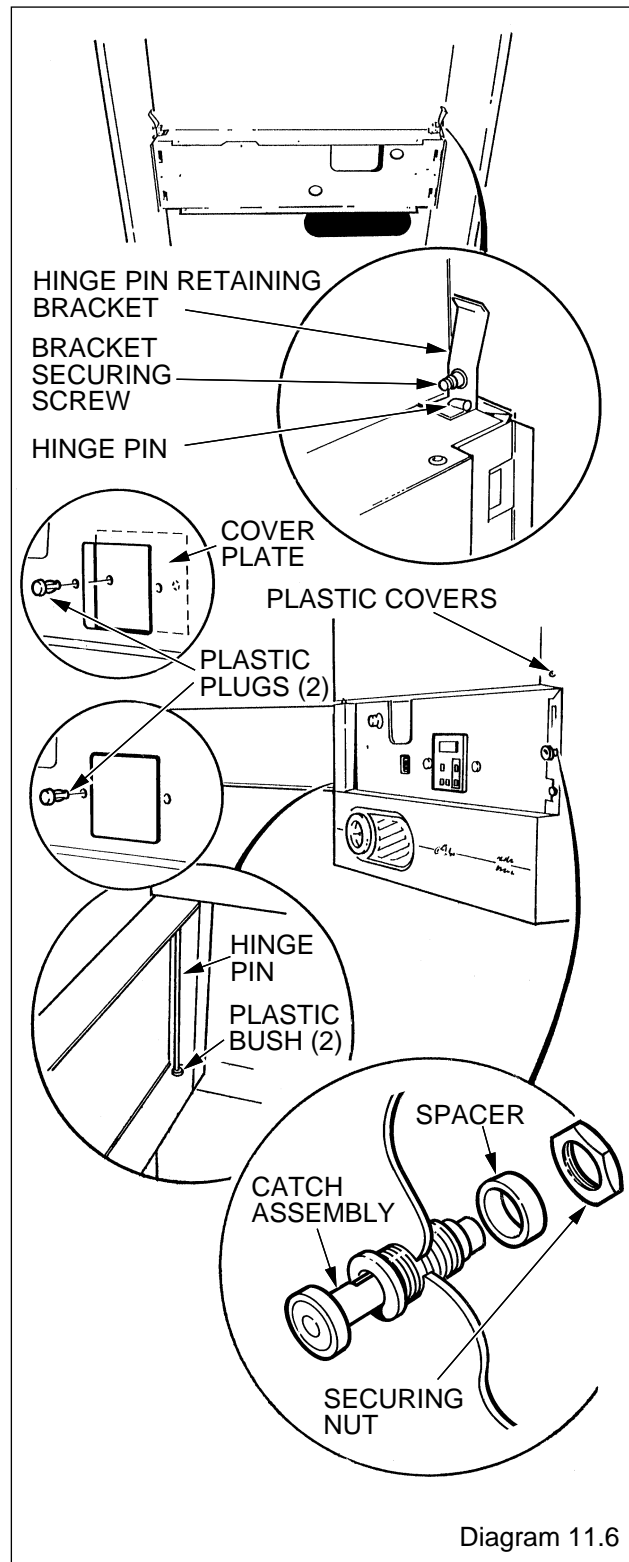

Diagram 11.6

Substances Hazardous to Health

The adhesives and sealants used in this appliance are cured and give no known hazard in this state.

INSULATION PADS/CERAMIC FIBRE, GLASSYARN, MINERAL WOOL

These can cause irritation to skin, eyes and the respiratory tract.

If you have a history of skin complaint you may be susceptible to irritation. High dust levels are usual only if the material is broken.

Normal handling should not cause discomfort, but follow normal good hygiene and wash your hands before eating, drinking or going to the lavatory.

If you do suffer irritation to the eyes or severe irritation to the skin seek medical attention.